

# PLYMOUTH 1946 thru 1953 BODY PARTS

Models P15, 17, 18, 19, 20, 22, 23 and 24. ALL BODY STYLES

## Sheet Metal

Typical of All Models

See Fig. 1

<b>1 FRONT BUFFER PLATE</b>		
1123504—1946 to 48.....		4.68
1135010—1949 .....		4.95
1319587—1950 (left*) .....		5.74
1324624—1951-52 (right*).....		5.74
1329455—1953 (right*) .....		5.74
<b>2 FRONT BUMPER FACE BAR</b>		
1115456—1946 to 48.....	25.14	
1134371—1949 .....	32.95	
1319566—1950 .....	32.95	
1321712—1951-52 .....	32.95	
1329450—1953 .....	32.95	
<b>3 SUPPORT BAR ASSEMBLY</b>		
1126528—1946 to 48 (left*)....	4.65	
1122327—1946 to 48 w/crossbar	10.58	
1137678—1949 .....	10.58	
1319572—1950 .....	10.58	
1321713—1951-52 .....	10.85	
1403858—1953 (right*) .....	4.75	
<b>4 RADIATOR LOWER CROSS BAR ASSEMBLY</b>		
1065878—1946 to 48.....	2.43	
1240486—1949-50 .....	1.86	
1346576—1951-52 .....	1.69	
<b>5 RADIATOR FRONT DUST SHIELD</b>		
1065881—1946-48 .....	2.74	
1239572—1949-50 .....	2.74	
<b>6 FRONT BUMPER TO RADIATOR STONE DEFLECTOR</b>		
1148792—1946 to 48 (right*)	2.95	
1239569—1949 .....	7.63	
1335470—1950 .....	7.58	
1346727—1951-52 w/air-scoop.	12.50	
1456386—1953 .....	9.75	
<b>7 PARKING LAMP BEZEL</b>		
1148001—1946 to 48 (right*)..	2.83	
1297815—1949 (right*) .....	2.55	
1440097—1953 (right*) .....	3.90	
<b>7A PARKING LAMP LENS</b>		
1149829—1946 to 48.....	.82	
1297789—1949 .....	.72	
1340270—1950 .....	1.03	
1345479—1951-52 .....	1.03	
1440093—1953 (right*) .....	1.03	
<b>7B PARKING LAMP LENS MOUNTING GASKET</b>		
1297817—1949 .....	.11	
1340407—1950 .....	.49	
1345478—1951-52 .....	.49	
1440100—1953 .....	.49	
<b>7C PARKING LAMP FRAME</b>		
1148001—1946 to 48 (right*)..	3.35	
<b>7D PARKING LAMP CABLE &amp; SOCKET ASSEMBLY</b>		
1244679—1949 .....	2.06	
1343264—1950 to 52.....	1.15	

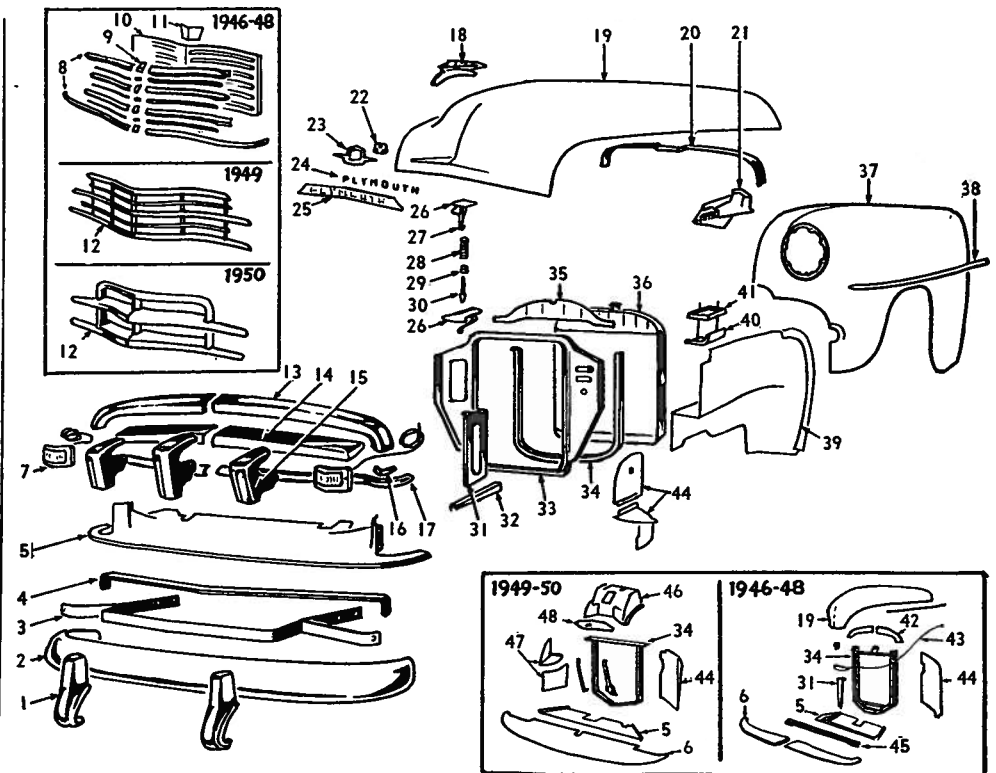
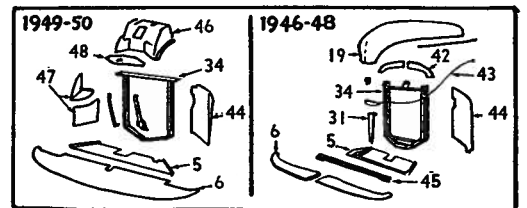
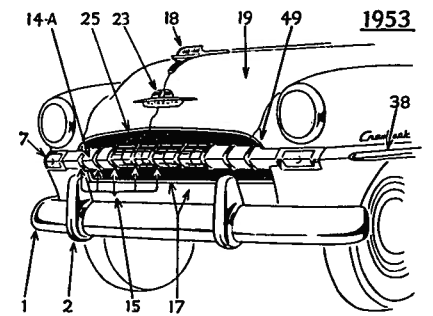

Fig. 1—Sheet Metal—Front End

<b>7E PARKING LAMP SOCKET ASSEMBLY</b>		
1241138—1949 .....		.32
1340408—1950 .....		.32
1343754—1951-52 .....		.45
1440111—1953 .....		.45
<b>7F PARKING LAMP SOCKET SPRING</b>		
44758—1949 .....		.03
<b>7G PARKING LAMP SOCKET INSULATOR</b>		
858245—1949 .....		.06
1345803—1951-52 .....		.07
<b>7H PARKING LAMP SOCKET CONTACT</b>		
657572—1949 .....		.02
<b>8 RADIATOR GRILLE MOLDING</b>		
1156650—1946 to 48, large, upper (right*) .....	4.52	
1156653—1946 to 48, large, intermediate, upper (right*)..	4.52	
1156656—1946 to 48, large, intermediate, lower (right*)..	4.52	
1065548—1946 to 48, large, lower (right) .....	5.41	
1065524—1946 to 48, large, lower (left) .....	5.41	
1156661—1946 to 48, small (right*) 3 used.....	1.37	
<b>8A RADIATOR GRILLE 1953</b>		



<b>9 RADIATOR GRILLE COVER MOLDING JOINTS</b>		
1156652—1946 to 48, large, upper .....	1.05	
1156655—1946 to 48, large, upper, intermediate .....	1.00	
1156658—1946 to 48, large, lower, intermediate .....	1.00	
1065772—1946 to 48, large, lower .....	.84	
1156665—1946 to 48, small (3 used) .....	.79	
<b>10 RADIATOR GRILLE PANEL AND REINFORCEMENT ASSEMBLY</b>		
1065883—1946 to 48.....	7.80	
<b>11 RADIATOR GRILLE LARGE MOLDING JOINT COVER ATTACHING PLATE</b>		
1156490—1946 to 48.....	.06	
<b>12 RADIATOR GRILLE ASSEMBLY</b>		
1242636—1949, chrome .....	56.20	
1335339—1950, chrome .....	62.63	



\* Opposite side one part number higher

BODY PARTS 1946 thru 1953 PLYMOUTH

Models P15, 17, 18, 19, 20, 22, 23 and 24. ALL BODY STYLES

Table of car parts and prices for models P15, 17, 18, 19, 20, 22, 23, and 24. Includes items like TOP RADIATOR GRILLE BAR, INTERMEDIATE RADIATOR GRILLE BAR, etc.

Table of car parts and prices for models P15, 17, 18, 19, 20, 22, 23, and 24. Includes items like HOOD LOCK ASSEMBLY, SAFETY CATCH, HOOD LOCK STRIKER SPRING, etc.

Table of car parts and prices for models P15, 17, 18, 19, 20, 22, 23, and 24. Includes items like RADIATOR SUPPORT TO FENDER YOKE, RADIATOR SUPPORT ASSEMBLY, RADIATOR CORE ASSEMBLY, etc.

continued

\* Opposite side one part number higher

**PLYMOUTH 1946 thru 1953 BODY PARTS**

**Models P15, 17, 18, 19, 20, 22, 23 and 24. ALL BODY STYLES**

**Sheet Metal—continued**

<b>40 BATTERY TRAY ASSEMBLY</b>	
957777—1946 to 48.....	1.03
957778—1946 to 48, w/heavy-duty battery .....	1.28
1142062—1949 to 52.....	2.37
1484497—1953 .....	....
<b>41 BATTERY HOLD DOWN STRAP</b>	
1324786—1946 to 50 .....	.91
865414—1946 to 48, w/heavy-duty battery .....	.91
1324786—1951 to 53 .....	.91
1324788—1951-52, w/heavy-duty battery .....	.96
<b>42 RADIATOR CORE TO HOOD TOP AIR SEAL PLATE</b>	
992870—1946 to 48 (right*)..	.47
<b>43 KNOB WIRE HOOD LOCKING CONTROL ASSEMBLY</b>	
1161445—1946 to 48.....	1.65
1300622—1949 .....	2.20
<b>44 RADIATOR SIDE SHIELD</b>	
1065893—1946 to 48 (right*)..	2.95
1242983—1949-50, upper (right) .....	1.86
1335451—1949-50, lower (right) .....	1.34
1335457—1949-50 (left) .....	3.18
1346591—1951-52, upper (right*) .....	1.37
1346565—1951-52, lower (right*) .....	1.34
<b>45 RADIATOR LOWER CROSS BAR</b>	
1065878—1946 to 48.....	2.43
<b>46 RADIATOR UPPER SHIELD</b>	
1240300—1949-50 .....	3.85
<b>47 RADIATOR SIDE SHIELD</b>	
1373352—1949-50 .....	2.94
<b>48 RADIATOR UPPER SHIELD HAND HOLE COVER</b>	
1240288—1949-50 .....	.47

**Body Sheet Metal**

**2 Dr. Sedans, Club Coupes, 3 Pass. Coupes**

See Fig. 2

<b>1 DASH PANEL</b>	
1245011—1949-50 .....	11.86
1367883—1951-52 .....	11.86
<b>2 COWL PANEL</b>	
943558—1946 to 48 (right*) ..	12.35
1245004—1949-50 (right*) ..	19.34
1348444—1951-52 (right*) .....	19.34
1431960—1953 (right*) .....	19.95
<b>3 DOOR PANEL</b>	
977504—1946 to 48 (right*)..	12.55
1304452—1949 (right*) .....	11.22
1304454—1950 (right*) .....	13.30
1381950—1951-52 (right*) .....	13.30

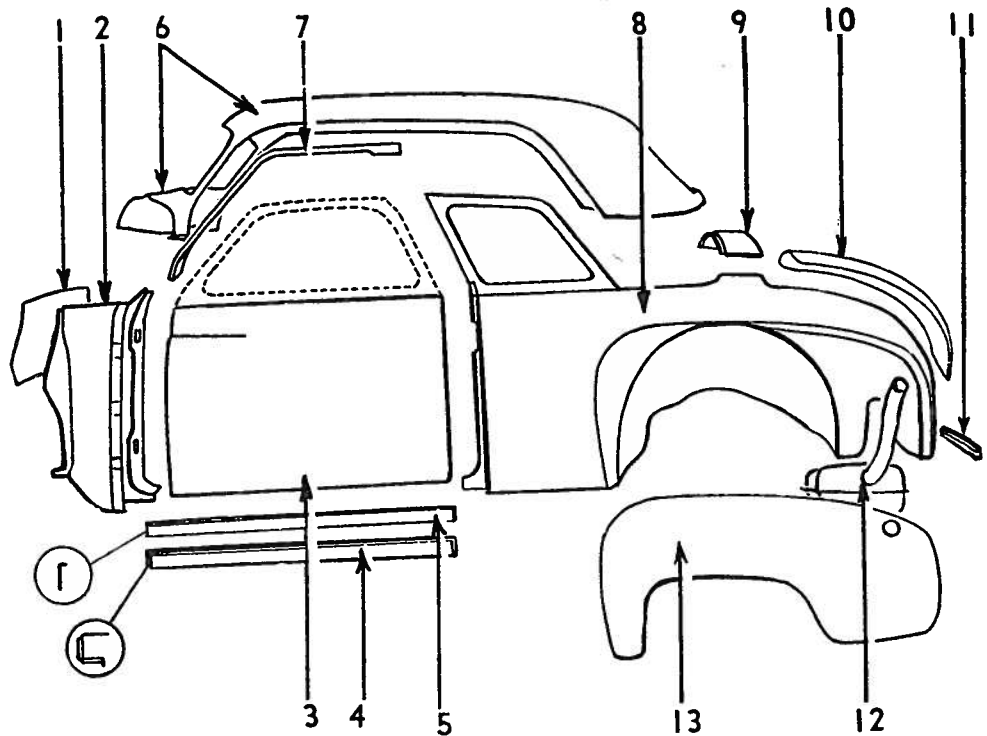

Fig. 2—Body Sheet Metal

<b>DOOR SHELL</b>	
1431308—1953, 3 cpe., cl. cp. (right*) .....	55.25
<b>4 BODY SILL PANEL, OUTER</b>	
943446—1946 to 48 (right*) ..	7.62
1245373—1949-50, 2 dr. sedan (right*) .....	5.52
1246123—1949-50, 3 pass cpe. (right*) .....	5.52
1245094—1949-50, club cpe (right*) .....	6.10
1348394—1951-52, 2 dr. sedan (right*) .....	5.52
1348392—1951-52, 3 pass cpe. (right*) .....	5.52
1348380—1951-52, club cpe. (right*) .....	6.10
<b>5 BODY SILL PANEL, INNER</b>	
1245375—1949 to 52, 2 dr. sedan (right*) .....	4.41
1246125—1949 to 52, 3 pass cpe. (right*) .....	4.41
1245380—1949 to 52 club cpe. (right*) .....	4.68
<b>6 ROOF PANEL ASSEMBLY</b>	
988239—1946 to 48, 2 dr. sedan ..	91.09
992044—1946 to 48, club cpe... ..	88.88
992878—1946 to 48, 3 pass. cpe. ..	88.88
1303378—1949, 2 dr. sedan (ie-pair panel) .....	32.59
1249215—1949, 3 pass cpe. ....	93.82
1249214—1949, club cpe. ....	104.85

1248494—1950, 2 dr. sedan ....	93.82
1338135—1950, 3 pass. cpe. ....	93.82
1338134—1950, club cpe. ....	104.85
1367935—1951-52, 2 dr. sedan. ....	93.82
1367934—1951-52, 3 pass. cpe... ..	93.82
1367933—1951-52, club cpe. ....	104.85
1431955—1953, 3 cp., cl. cp. ....	104.85
1431291—1953, 2 dr. sdn. ....	104.85
1497547—1953, sp. cl. cp. ....	143.75
<b>7 ROOF SIDE RAIL</b>	
1248783—1949-50, 2 dr. sedan (right*) .....	2.63
1246331—1949, 3 pass. cpe. (right*) .....	.86
1247862—1949-50, club cpe. (right*) .....	3.01
1245353—1950, 3 pass. cpe. (right*) .....	.86
1367846—1951-52, 2 dr. sedan (right*) .....	2.63
1245762—1951-52, club cpe. (right*) .....	5.78
1433108—1953, 2 dr. sdn. (right*) .....	2.50
1457132—1953, sp. cl. cp. (right*) .....	3.25
<b>8 REAR QUARTER PANEL ASSEMBLY</b>	
977265—1946 to 48, 2 dr. sedan (right*) .....	56.87
1249692—1949, 3 pass. cpe. (right*) .....	76.74
1338994—1949, club cpe. (right*) .....	76.74

\* Opposite side one part number higher

# BODY PARTS 1946 thru 1953 PLYMOUTH

Models P15, 17, 18, 19, 20, 22, 23 and 24. ALL BODY STYLES

1341792—1950, 2 dr. sed. (right*) .....	76.74
1341010—1950, 3 pass. cpe. (right*) .....	57.97
1338994—1950, club cpe. (right*) .....	76.74
1367602—1951-52, 2 dr. sed. (right*) .....	76.74
1368288—1951-52, 3 pass cpe. (right*) .....	57.97
1367596—1951-52, club cpe. (right*) .....	76.74
1433330—1953, 2 dr. (right*)..	68.75
1433678—1953, 3 cp. (right*)..	68.75
1433332—1953, cl. cp. (right*)	68.75
1458116—1953, sp. cl. cp. (right*) .....	.....

## 9 LUGGAGE COMPARTMENT OPENING PANEL

124581—1949, 2 dr. sedan ...	2.21
1245342—1949 to 52, 3 pass cpe.	3.31
1245164—1949-50, club cpe. ...	2.47
1367306—1951-52, club cpe. ...	4.04
1432916—1953, 2 dr., sp. cl. cp.	9.85
1433066—1953, 3 cp., cl. cp. ...	12.25

## 10 DECK LID

1152689—1946 to 48, 2 dr. sedan	34.80
1248529—1949, 2 dr. sedan ....	37.00
1245369—1949, 3 pass. cpe. ...	41.42
1245058—1949, club cpe. ....	39.21
1338767—1950-51, 2 dr. sedan..	37.00
1338772—1950-51, 3 pass. cpe..	41.42
1477816—1950-51, club cpe. ...	39.21
1477819—1952, 2 dr. sed. ....	37.00
1477822—1952, 3 pass. cpe. ...	41.42
1477816—1952, club cpe. ....	39.21
1431094—1953, all exc. cl. cp. ...	39.25

## 11 REAR END PANEL REPAIR

944173—1946 to 48, 2 dr. sedan	6.31
984878—1946 to 48, 3 pass. cpe., club cpe. ....	6.31
1303085—1949, 3 pass. cpe. ...	6.88
1303092—1949 to 52, 2 dr. sedan	6.88
1303085—1950 to 52, 3 pass. cpe. & club cpe. ....	6.88

## 12 FUEL TANK ASSEMBLY

1138587—1949 to 52 .....	16.25
1483601—1953, all .....	16.25

## 13 REAR FENDER ASSEMBLY

1148953—1946 to 48 (right*)..	18.22
1303386—1949, 2 dr. sed. (right*) .....	17.02
1243452—1949, 3 pass. cpe., club cpe. (right*) .....	18.22
1334095—1950—2 dr. sed. (right*) .....	17.02
1364829—1950, 3 pass. cpe., club cpe. (right*) .....	18.22
1364728—1951, 2 dr. sed. (right*) .....	17.02
1364829—1951, 3 pass. cpe., club cpe. (right*) .....	18.22

## Body Moldings, Wheels and Glass

2 Door Sedan  
See Fig. 3

### 1 ORNAMENT

1065766—1946-48 .....	5.95
1335472—1949 .....	5.95
1335472—1950 .....	5.95
1373393—1951 .....	2.75
1456316—1952 .....	4.75
1456363—1953 .....	4.75

### 2 TOP HOOD MOLDING

1065778—1946-48, side (right*)	2.95
1065758—1946-48, center (front) .....	.27
951902—1946-48, center (rear) .....	1.37
1308612—1949, P-18, center (front) .....	.68
1299361—1949, P-18 (front)..	6.45
1298932—1949-50 .....	2.22
1335564—1950 (front) .....	3.25
1308612—1950 (joint) (front) .	.68
1347248—1951 .....	2.10
1435427—1951 (front) .....	5.40
1347435—1951 (joint) (front) .	.74
1456283—1952 .....	1.65
1435427—1952 (front) .....	5.40

### 3 WINDSHIELD DIVISION BAR

848408—1946-48 (white) .....	.99
897087—1946-48 (chrome) ....	1.64
1246405—1949 (white) .....	1.09
1249488—1949 (chrome) .....	1.91
1249489—1950 (white).....	.99
1367422—1951-52 (chrome) ...	1.91

### 4 OUTSIDE FINISH MOLDING JOINT CLIP

1244844—1949 (upper) .....	.16
1244845—1949-50 (lower) ....	.16
1380269—1951-52 (lower) ....	.47

### 5 WINDSHIELD GLASS

843405—1946-48 .....	P.O.A.
1249258—1949-50 .....	P.O.A.
1367307—1951-52 .....	P.O.A.
1249334—1949, weatherstrip ..	7.57
1304469—1950, weatherstrip ..	7.57
1431111—1951-51, weatherstrip	9.83

### 6 WINDSHIELD OUTSIDE FINISH MOLDING

848410—1946-48 (right*) ....	1.57
1246424—1949 (right*) .....	2.16
1367520—1951-52 (right*) ....	1.74

### 7 FRONT DOOR VENTILATING WING GLASS FRAME

848856—1946-48 .....	1.94
1303862—1949 (right*) .....	2.94
1303862—1950-52 (right*)....	2.94
1497020—1953 (right*) .....	4.15

### 8 VENTILATOR WING GLASS

848698—1946-48 .....	P.O.A.
1245165—1949 .....	P.O.A.
1249735—1950-52 .....	P.O.A.
1432837—1953 .....	P.O.A.

### 9 VENT WING WEATHERSTRIP RETAINER ASSEMBLY

1249562—1949-50 (incl's div. chanl.) (right*) .....	4.16
1431396—1951-52 (incl's div. chanl.) right*) .....	4.53
1459204—1953 (right*) .....	4.55

### 10 DOOR GLASS

849008—1946-48 .....	P.O.A.
1248729—1949-52 .....	P.O.A.
1432544—1953 .....	P.O.A.

### 11 FRONT QUARTER WINDOW GLASS

848677—1946-48 .....	P.O.A.
1249056—1949-52 .....	P.O.A.
1432641—1953 .....	P.O.A.

continued

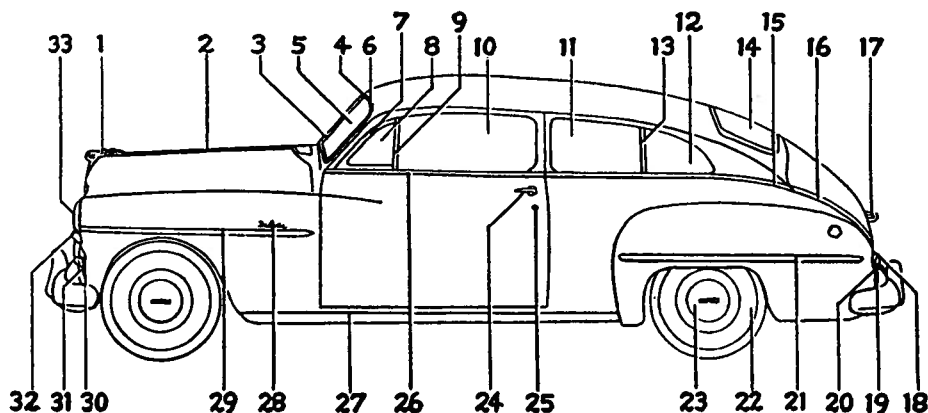

Fig. 3—Moldings, Wheels and Glass, 2-door

\* Opposite side one part number higher

**PLYMOUTH 1946 thru 1953 BODY PARTS****Models P15, 17, 18, 19, 20, 22, 23 and 24. ALL BODY STYLES****Body Moldings, Wheels and Glass—continued**

<b>12 REAR QUARTER WINDOW GLASS</b>	
1249032—1949-50 .....	P.O.A.
1367924—1951-52 .....	P.O.A.
<b>13 REAR QUARTER WINDOW WEATHERSTRIP</b>	
1249033—1949-50 (right*) .....	2.94
1368062—1951-52 (right*) .....	2.94
<b>14 REAR WINDOW GLASS</b>	
1249304—1949-50 .....	P.O.A.
848054—1946-48 .....	P.O.A.
1367367—1951-52 .....	P.O.A.
1431799—1953 .....	P.O.A.
<b>15 QUARTER PANEL OUTSIDE FINISH MOLDING</b>	
1065839—1946-48 (right*) .....	2.79
1303478—1949-52 (right*) .....	2.79
1477926—1953 .....	3.75
<b>16 LUGGAGE COMPARTMENT LID MOLDING</b>	
1305752—1950-52 (right*) .....	4.26
<b>17 LICENSE LAMP LENS BEZEL, COVER</b>	
1154287—1946-48 .....	1.47
1244779—1949 .....	2.15
1343283—1950-52 .....	1.89
<b>18 LICENSE LAMP HOUSING</b>	
1343310—1950-52 .....	13.25
1383210—1953 .....	1.15
<b>19 TAIL LAMP REFLECTOR</b>	
1163607—1946-48 .....	.63
1253173—1949 .....	.21
1235512—1950-52 .....	.21
<b>20 TAIL LAMP LENS</b>	
1154325—1946-48 .....	.83
1300567—1949 (right*) .....	2.17
1343379—1950 (right*) .....	7.15
1345853—1951-52 (right*) .....	1.06
1436451—1953 .....	1.85
<b>21 REAR FENDER MOLDING</b>	
1334081—1950 .....	3.74
1364764—1951-52 (right*) .....	4.31
1477926—1953 .....	3.75
<b>22 WHEEL</b>	
1320042—1949 .....	9.83
1320042—1950 to 53 .....	9.83
<b>23 WHEEL HUB CAP</b>	
1117708—1946-48, std. & deluxe cars .....	2.43
1117707—1946-48, custom & spec. deluxe .....	3.90
1316707—1949 .....	2.70
1142878—1950 .....	3.90
1324127—1951-52 .....	3.55
1408539—1953 .....	7.50

<b>24 DOOR HANDLE, OUTSIDE</b>	
1161290—1946-48 (right*) .....	2.56
1246408—1949-52 (right*) .....	2.94
1433104—1953 (right*) .....	2.80
<b>25 DOOR LOCK CYL. &amp; KEYS</b>	
992586—1946-48 .....	1.89
1163772—1946-48, waterproof .....	2.00
1315510—1949-52 .....	2.21
<b>26 OUTSIDE FINISH MOLDING</b>	
1065828—1946-48 .....	2.05
1246646—1949 (right*) .....	2.57
1305530—1950 (right*) .....	2.57
1368192—1951-52 (right*) .....	2.57
<b>27 BODY SILL SIDE MOLDING</b>	
1149182—1946-48 (right*) .....	8.41
1249456—1950 (right*) .....	7.83
1349114—1951-52 (right*) .....	7.99
<b>28 FENDER NAME PLATE</b>	
1148645—1946-48, P-15S (hood side) .....	1.28
1148646—1946-48, P-15C (hood side) .....	1.48
1065759—1946-48 (center panel) .....	1.48
1253713—1949-50, spec. deluxe .....	1.38
1253712—1949-50, deluxe .....	1.15
1373081—1951, sub. domestic .....	1.92
1373034—1951, Savoy spec. sub. .....	1.88
1373033—1951-52, Concord .....	1.77
1456100—1953, Cambridge .....	2.10
<b>29 FRONT FENDER MOLDING</b>	
1065541—1946-48 (right*) .....	2.90
1298328—1949 (right*) .....	3.04
1335572—1950 (extension) (right*) .....	1.19
1335335—1950 (right*) .....	3.92
1346774—1951-52 .....	3.02
1456227—1953 (right*) .....	3.90
<b>30 PARKING LAMP BEZEL</b>	
1148001—1946-48 (right*) .....	2.83
1297815—1949 (right*) .....	2.55
1297811—1949 (housing) (right*) .....	1.51
1297818—1949 (gasket) .....	.25
1340394—1950 (housing) (right*) .....	2.60
1345610—1951-52 (right*) .....	3.75
1345606—1951-52 (housing) (right*) .....	2.95
1345476—1951-52 (gasket) .....	.15
1343305—1950 (outer retainer) (right*) .....	1.55
1343301—1950 (inner retainer) (right*) .....	1.45
1244679—1949, cable & socket .....	2.06
1244681—1949, cable & socket & dir. sig. imp. assy. ....	2.89
1343264—1950-52, cable & socket .....	1.15
1343266—1950-52, cable & socket & dir. sig. imp. assy. ....	1.58
1440097—1953 (right*) .....	3.90

<b>31 PARKING LAMP LENS</b>	
1148861—1946-48 .....	.51
1297789—1949 .....	.72
1340270—1950 .....	1.03
1345479—1951-52 .....	1.03
1440093—1953 (right*) .....	1.03
<b>32 HEADLAMP DOOR</b>	
1148824—1946-48 (right*) .....	4.63
1239411—1949-52 .....	2.50
1345670—1953 .....	3.95
<b>33 HEADLAMP BULB RETAINING RING</b>	
946942—1946 to 53 .....	1.82
<b>Body Sheet Metal and Fuel Tank</b>	
<i>4 Door Sedan</i>	
<i>See Fig. 4</i>	
<b>1 DASH PANEL</b>	
1245011—1949-50 .....	11.86
1367883—1951 .....	11.86
<b>2 COWL SIDE PANEL ASSEMBLY</b>	
943558—1946 to 48 (right*) .....	12.35
1245004—1949-50 (right*) .....	19.34
1348444—1951-52 (right*) .....	19.34
1431960—1953 (right*) .....	19.95
<b>3 FRONT DOOR PANEL</b>	
977504—1946 to 48 (right*) .....	12.55
1304452—1949 (right*) .....	11.22
1304452—1950 (right*) .....	11.22
1381948—1951-52 (right*) .....	11.22
<b>DOOR SHELL</b>	
1431296—1953 (right*) .....	50.26
<b>4 BODY CENTER PILLAR</b>	
943091—1946 to 48 (right*) .....	8.89
1249210—1949-50 (right*) .....	11.04
1367384—1951-52 (right*) .....	11.04
1431476—1953 (right*) .....	16.50
<b>5 REAR DOOR PANEL</b>	
977504—1946 to 48 (right*) .....	12.55
1303132—1949 to 52 (right*) .....	10.10
1431330—1953 (right*) .....	50.26
<b>6 BODY OUTER SIDE SILL</b>	
1245092—1949-50 (right*) .....	6.10
1347812—1951-52 (right*) .....	6.10
<b>7 BODY INNER SIDE SILL</b>	
1245377—1949 to 52 (right*) .....	4.68
<b>8 ROOF ASSEMBLY</b>	
988239—1946 to 48 .....	91.09
1249212—1949 .....	104.85
1338133—1950 .....	104.85
1367932—1951-52 .....	104.85
1431291—1953 .....	104.85

\* Opposite side one part number higher

# BODY PARTS 1946 thru 1953 PLYMOUTH

Models P15, 17, 18, 19, 20, 22, 23 and 24. ALL BODY STYLES

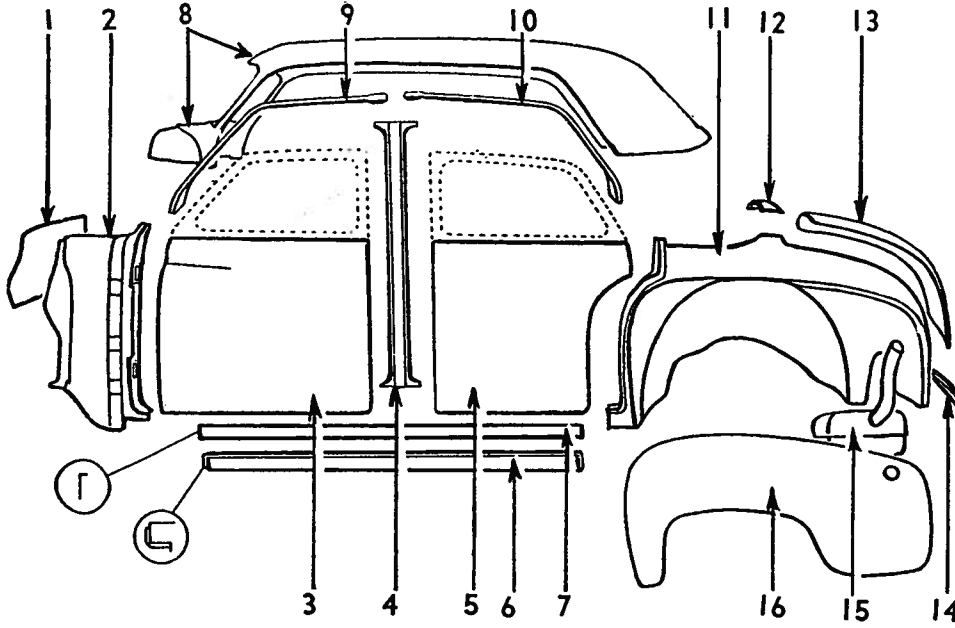

Fig. 4—Body Sheet Metal and Fuel Tank, 4-door

<b>9 ROOF SIDE RAIL FRONT</b>		
1245347—1949-50 (right*)	....	2.00
1367396—1951-52 (right*)	....	2.00
1431992—1953 (right*)	....	2.00
<b>10 ROOF SIDE RAIL REAR</b>		
1246714—1949-50 (right*)	....	3.01
1367372—1951-52 (right*)	....	2.26
<b>11 REAR QUARTER PANEL</b>		
977267—1946 to 48 (right*)	....	49.67
1338986—1949 (right*)	....	53.56
1338986—1950 (right*)	....	53.56
1367726—1951-52 (right*)	....	53.56
1433328—1953 (right*)	....	49.75
<b>12 TRUNK COMPARTMENT OPENING PANEL</b>		
1245160—1949-50	....	1.94
1367305—1951-52	....	3.31
1432916—1953	....	9.85
<b>13 DECK LID ASSEMBLY</b>		
1152689—1946 to 48	....	34.80
1245058—1949	....	39.21
1477816—1950 to 52	....	39.21
1431094—1953	....	39.25
<b>14 REAR END PANEL</b>		
944173—1946 to 48	....	6.31
1303085—1949 to 52	....	6.88
<b>15 FUEL TANK</b>		
1138587—1949 to 52	....	16.25
1483601—1943	....	16.25
<b>16 REAR FENDER</b>		
1148953—1946 to 48 (right*)	..	18.22

1243452—1949 (right*)	....	18.22
1364829—1950 (right*)	....	18.22
1364829—1951 (right*)	....	18.22

## Body Moldings, Wheels and Glass

4 Door Sedan  
See Fig. 5

<b>1 HOOD TOP ORNAMENT</b>		
1065766—1946 to 48	....	5.95
1335472—1949	....	5.95
1335472—1950	....	5.95
1373393—1951	....	2.75
1456316—1952	....	4.75
1456363—1953	....	4.75

<b>2 TOP HOOD MOLDING</b>		
901902—1946 to 48	....	1.37
1298932—1949-50	....	2.22
1347248—1951	....	2.10
1456283—1952	....	1.23
1435427—1952 (front)	....	5.40
<b>3 WINDSHIELD DIVISION BAR (White)</b>		
848408—1946 to 48 (white)	....	.99
897087—1946 to 48 (chrome)	..	1.64
1246405—1949-50 (white)	....	1.09
1246404—1949-50 (spec. deluxe)	....	1.91
1367422—1951-52	....	1.91
<b>4 WINDSHIELD OUTSIDE MOLDING JOINT CLIP</b>		
1244844—1949-50, upper	....	.16
1244845—1949-50, lower	....	.16
<b>5 WINDSHIELD GLASS</b>		
892189—1946 to 48	....	P.O.A.
1245188—1949-50	....	P.O.A.
1367307—1951-52	....	P.O.A.
1245189—1949, weather-strip- ping	....	7.72
1246000—1950, weather-strip- ping	....	7.72
1431111—1951-52, weather- stripping	....	9.83
1432404—1953	....	P.O.A.
<b>6 OUTSIDE FINISH MOLDING</b>		
892380—1946 to 48 (right*)	...	1.74
1246424—1949-50 (right*)	...	2.16
1367336—1951-52, upper (right*)	....	2.10
1367434—1951-52 lower (right*)	....	1.74
1477568—1953, upper	....	1.85
1477718—1953, side (right*)	..	2.50
1477569—1953, lower	....	2.00
<b>7 FRONT DOOR VENTILATING WINDOW FRAME</b>		
892836—1946 to 48 (right*)	...	4.41
1303845—1949 (right*)	....	3.04
1303845—1950-52 (right*)	....	3.04

continued

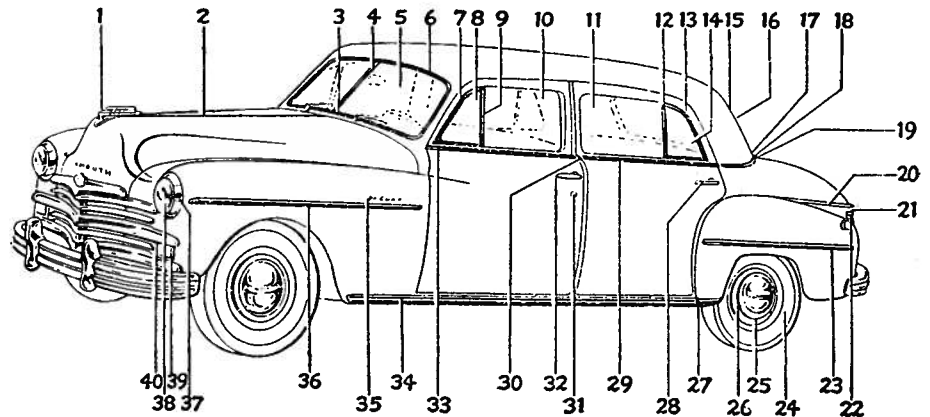

Fig. 5—Body Moldings, Wheels and Glass, 4-door

\* Opposite side one part number higher

**PLYMOUTH 1946 thru 1953 BODY PARTS****Models P15, 17, 18, 19, 20, 22, 23 and 24. ALL BODY STYLES****Body Moldings, Wheels and Glass—continued**

<b>8 VENTILATOR WING GLASS</b>		<b>16 REAR WINDOW GLASS</b>		<b>29 REAR DOOR MOLDING</b>	
892435—1946 to 48 .....	P.O.A.	892-95—1946 to 48 .....	P.O.A.	1065832—1946 to 48 .....	1.57
1245165—1949 to 52 .....	P.O.A.	1245162—1949 .....	P.O.A.	1246578—1949 to 52 (right*)..	2.05
1433312—1953 (right*) .....	3.00	1337036—1950 .....	P.O.A.		
<b>9 FRONT DOOR CHANNEL DIVISION MOLDING</b>		1367516—1951-52 .....	P.O.A.	<b>30 CENTER PILLAR MOLDING</b>	
1296601—1949 (outer) .....	.63	1431799—1953 .....	N.P.	1246580—1949 to 52 .....	.58
1296602—1949 (inner) .....	.68	<b>17 REAR WINDOW LOWER MOLDING</b>		<b>31 OUTSIDE DOOR LOCK</b>	
1296601—1950 (outer) .....	.63	1337087—1950 .....	1.94	992586—1946 to 48 .....	1.89
1296602—1950 to 52 (inner) ..	.68	1368173—1951-52 .....	2.99	1163772—1946 to 48 (water proof type) .....	2.00
1433314—1953, outer .....	.35	1953—See item No. 15. ....		1315510—1949 to 52 .....	2.21
1433315—1953, inner .....	.40	<b>18 REAR WINDOW LOWER CORNER MOLDING</b>		<b>32 FRONT DOOR HANDLE</b>	
<b>9 FRONT DOOR VENT. WING WEATHERSTRIP RETAINER ASSEMBLY</b>		1337091—1950 .....	.95	1161290—1946 to 48 (right*)..	2.56
1304438—1949 (includes division channel) (right*) .....	4.16	<b>19 ROOF PANEL OUTSIDE MOLDING</b>		1246408—1949 to 52 (right*)..	2.94
1304438—1950 (right*) .....	4.16	1246257—1949-50 (right*)....	3.04	1433104—1953 (right*) .....	2.80
1304439—1950 (left) .....	4.16	<b>20 TAIL LAMP CAP</b>		<b>33 FRONT DOOR MOLDING</b>	
1431400—1951-52 (right*) .....	4.53	1300560—1949 .....	3.09	1065824—1946 to 48 (right*)..	1.79
1459204—1953 (right*) .....	4.55	<b>20 TAIL AND STOP LAMP BEZEL</b>		1246577—1949-50 (right*) .....	2.05
<b>10 FRONT DOOR GLASS</b>		1343109—1950 to 52 (right*)..	3.95	1349082—1951-52 (right*) .....	2.05
848611—1946 to 48 .....	P.O.A.	1436442—1953 .....	4.45	<b>34 BODY SILL MOLDING</b>	
1245159—1949 to 52 .....	P.O.A.	<b>20 TAIL LAMP HOUSING</b>		1149182—1946 to 48 (right*)..	8.41
1432546—1953 .....	N.P.	1339867—1949 (right*) .....	6.62	1249454—1949 (right*) .....	8.41
<b>11 REAR DOOR GLASS</b>		1333981—1950 (right*) .....	.95	1249454—1950 (use w/o fender shield) (right*) .....	8.41
848647—1946 to 48 .....	P.O.A.	1343113—1951-52 (right*) .....	2.55	1341130—1950 (use w/fender shield) (right*) .....	8.09
1245063—1949 to 52 .....	P.O.A.	1436452—1953 .....	1.70	1349102—1951-52 (use w/o fender shield) (right*) .....	8.53
1432481—1953 .....	N.P.	<b>21 TAIL AND STOP LIGHT LENS</b>		1349118—1951-52 (use w/fender shield) (right*) .....	8.26
<b>12 REAR DOOR VENT. WING WEATHERSTRIP ASSEMBLY</b>		1149367—1946 to 48 (right*)..	1.12	<b>35 NAME PLATE</b>	
1245242—1949-50 (right*) .....	4.16	1300567—1949 (right*) .....	2.17	1148645—1946 to 48, P-15-S (hood side) .....	1.28
1348366—1951-52 (right*) .....	4.16	1340146—1950 to 52 (right*)..	1.12	1148646—1946 to 48, P-15-C (hood side) .....	1.48
1459204—1953 (right*) .....	4.55	1436451—1953 .....	1.85	1065759—1946 to 48 (center panel) .....	1.48
<b>13 REAR DOOR VENTILATOR FRAME</b>		<b>22 REFLECTOR</b>		1253713—1949, special deluxe f/fender side .....	1.38
892668—1946 to 48 (right*)..	4.41	1253173—1949 .....	.21	1253712—1949-50, deluxe f/fender side .....	1.15
1303866—1949 (right*) .....	2.47	1235512—1950 to 52 .....	.21	1373081—1951-52, Suburban... ..	2.10
1303866—1950 to 52 (right*)..	2.47	<b>23 REAR FENDER MOLDING</b>		1373034—1951-52, Savoy spec. Suburban .....	2.10
1433800—1953 (right*) .....	3.30	1246225—1949 (right*) .....	3.59	1373051—1951-52, Utility .....	1.92
<b>14 REAR DOOR VENTILATOR GLASS</b>		1333836—1950 .....	3.95	1373033—1951-52, Concord (except Suburban) .....	2.10
892436—1946 to 48 .....	P.O.A.	1349206—1951-52 (right*) .....	4.31	1456100—1953, Cambridge .....	2.10
1245168—1949 to 52 .....	P.O.A.	1458108—1953 .....	3.75	1456101—1953, Cranbrook .....	2.10
1457178—1953, P24-1 .....	N.P.	<b>24 STEEL WHEEL ASSEMBLY</b>		<b>36 FRONT FENDER MOLDING</b>	
1433059—1953, P24-1 .....	N.P.	1320042—1949 (15x4.50) .....	9.83	1065541—1946 to 48 (right*)..	2.90
<b>15 REAR WINDOW MOLDING</b>		1320042—1950 to 53 (15x4.50) ..	9.83	1298328—1949 (right*) .....	3.04
892546—1946 to 48 .....	2.52	<b>25 WHEEL COVER</b>		1335335—1950 (right*) .....	3.92
1245960—1949 .....	2.94	1142852—1949 (15x4.50) .....	4.58	1346774—1951-52 .....	3.02
1337048—1950, upper (right) ..	1.47	1316723—1950 .....	7.50	1456227—1953 (right*) .....	3.90
1337048—1950, upper (right)..	1.47	1326891—1951-52 .....	7.50	<b>37 HEADLAMP DOOR</b>	
1337087—1950, lower .....	1.94	1408539—1953 .....	7.50	1148824—1946 to 48 (right*)..	4.63
1337090—1950, lower corner (right*) .....	.95	<b>26 WHEEL HUB CAP</b>		1239411—1949 to 52 .....	2.50
1368080—1951-52, upper (right*) .....	1.74	1142878—1949 .....	3.90	1345670—1953 .....	3.95
1368173—1951-52, lower .....	2.99	1316707—1950 .....	3.90	<b>38 SEAL BEAM BULB ASSEMBLY</b>	
1433288—1953, up. (right*)..	1.95	1324127—1951 .....	3.55	853369—1946 to 48 .....	1.65
1492210—1953, low. (right*)..	1.75	<b>27 REAR FENDER SHIELD</b>		1297667—1949 to 53 .....	1.95
		1299819—1949 (right*) .....	5.85		
		1333979—1950 (right*) .....	6.62		
		1367260—1951-52 (right*) .....	5.91		
		1477906—1953 (right*) .....	4.31		
		<b>28 REAR DOOR HANDLE</b>			
		1161290—1946 to 48 (left*) ..	2.56		
		1246408—1949 to 52 (right*)..	2.94		
		1433104—1953 (right*) .....	2.80		

\* Opposite side one part number higher

# BODY PARTS 1946 thru 1953 PLYMOUTH

Models P15, 17, 18, 19, 20, 22, 23 and 24. ALL BODY STYLES

<b>39 PARKING LAMP BEZEL</b>		
1148001—1946 to 48 (right*)..	2.83	
1297815—1949 (right*) .....	2.55	
1345610—1951-52 (right*) .....	3.75	
1440097—1953 (right*) .....	3.90	
<b>39 PARKING LAMP GASKET</b>		
1297818—1949 .....	.25	
1340406—1950 .....	.49	
1340407—1950 (rubber) .....	.49	
<b>39 PARKING LAMP HOUSING</b>		
1297811—1949 (right*) .....	1.75	
1340394—1950 (right*) .....	2.60	
1345606—1951-52 (right*) .....	2.95	
1440103—1953 (right*) .....	2.50	
<b>39 PARKING LAMP LENS OUTER RETAINER</b>		
1343305—1950 (right*) .....	1.55	
<b>39 PARKING LAMP LENS INNER RETAINER</b>		
1343301—1950 (right*) .....	1.45	
<b>39 SIGNAL LAMP CABLE</b>		
1244681—1949 .....	2.89	
1343266—1950 .....	1.58	
1345512—1951-52 .....	1.47	
<b>39 PARKING LAMP CABLE &amp; SOCKET</b>		
1244679—1949 .....	2.06	
1343264—1950 to 52 .....	1.15	
<b>40 PARKING LAMP LENS</b>		
1148861—1946 to 48 .....	.51	
1297789—1949 .....	.72	
1340270—1950 .....	1.03	
1345479—1951-52 .....	1.03	
1440093—1953 (right*) .....	1.03	

## Front Door

2 & 4 Door  
See Fig. 6

<b>1 DOOR LESS TRIM, GLASS &amp; HARDWARE</b>		
1249190—1949-50, 4 dr. sed. (right*) .....	50.26	
1249194—1949-50, 2 dr. sed. (right*) .....	53.65	
1249198—1949, club cpe. (right*) .....	53.65	
1249203—1949-50, 3 pass. cpe. (right*) .....	53.65	
1249198—1950, club cpe, Suburban (right*) .....	53.65	
1459626—1951-52, 4 dr. sed. (right*) .....	50.26	
1348256—1951-52, 2 dr. sed. (right*) .....	53.65	
1348264—1951-52, 3 pass. cpe. (right*) .....	53.65	
1348946—1951-52, club cpe., suburban (right*) .....	53.65	
1431296—1953, 4 dr. sed. (right*) .....	50.26	
1431308—1953, 3 cp. (right*)..	55.25	
<b>2 REGULATOR OR PLATE AND LINK</b>		
1152967—1946 to 48, 4 dr. sed. (right*) .....	2.62	
1154026—1946 to 48, 2 rd. sed., 3 pass. cpe., club cpe. (right*) ..	2.86	
1245147—1949 to 52, 4 dr. sed. conv. cpe. (right*) .....	4.41	
1254954—1949-50, sta. wgn. (right*) .....	5.78	
1245638—1949-50, 2 dr. sed., 3 pass. cpe., club cpe., suburban (right*) .....	6.28	
1347690—1951-52, 2 dr. sed., 3 pass. cpe., club cpe., suburban (right*) .....	6.28	

1249650—1951-52, conv. cpe., spec. club cpe. (right*) .....	6.75
1432622—1953, 4 dr. sed. (right*) .....	4.41

<b>3 TOP AND LOCK PILLAR DOOR GLASS RUN</b>		
945420—1946 to 48, 4 dr. sed. (right*) .....	1.10	
945424—1946 to 48, 2 dr. sed. (right*) .....	1.30	
982108—1946 to 48, 3 pass. cpe., club cpe. (right*) .....	1.26	
1305627—1949-50, club cpe., suburban .....	1.52	
1245858—1949-50, 3 pass. cpe. ...	1.68	
1245478—1949-52, 4 dr. sed. ...	1.47	
1249287—1949 to 52, 2 dr. sed. ...	1.68	
1305627—1951-52, 3 pass. cpe. & suburban .....	1.52	
1432828—1953, 4 dr. sed. ....	2.65	
1432826—1953, 2 dr., 3 cpe. ...	2.80	

<b>4 FRONT DOOR GLASS DIVISION CHANNEL RUN</b>		
1245220—1949-52, 4 dr. sed., 3 pass. cpe., club cpe., suburban sta. wgn. ....	1.21	
1249262—1949-52, 2 dr. sed. ...	1.15	
1246613—1949-52, conv. cpe. ...	1.10	
1433334—1953, all .....	1.21	

<b>5 FRONT DOOR GLASS</b>		
848611—1946 to 48, 4 dr. sed. ...	P.O.A.	
892224—1946 to 48, 2 dr. sed. ...	P.O.A.	
902411—1946 to 48, club cpe., 2 pass. cpe. ....	P.O.A.	
1245625—1949 to 52, club cpe., suburban .....	P.O.A.	
1245798—1949 to 52, 3 pass. cpe. ...	P.O.A.	
1245159—1949 to 52, 4 dr. sed. ...	P.O.A.	
1245635—1949-50, conv. cpe. ...	P.O.A.	
1254846—1949-50, sta. wgn. ...	P.O.A.	
1248729—1949 to 52, 2 dr. sed. ...	P.O.A.	
1381293—1951-52, conv. cpe. ...	P.O.A.	
1381451—1951-52, spec. cl. cpe. ...	P.O.A.	
1432546—1953, 4 dr. sed. ....		
1432546—1953, 4 dr. sed. ....	N.P.	
1432544—1953, 2 dr., 3 cpe. cl. cpe. ....	N.P.	
1433358—1953, spec. cl. cpe. ...	N.P.	

<b>6 REGULATOR HANDLE</b>		
1152364—1946 to 48 .....	1.14	
1246027—1949-50, 4 dr. club cpe., conv. cpe. ....	2.21	
1248039—1949 to 52, 2 dr., 3 pass. cpe. sub. ....	2.21	
1331604—1949-50, sta. wgn. ...	1.63	
1381278—1951-52, 4 dr. club cpe., spec. club cpe. ....	1.63	
1248039—1953, all .....	2.21	

<b>7 DOOR HINGE</b>		
1347652—1949-50, 4 dr., 2 dr., 3-pass. cpe., club cpe., conv. cpe., sub. (upper) (right*)..	3.32	
1254703—1949-50, sta. wgn. (upper) (right*) .....	4.34	

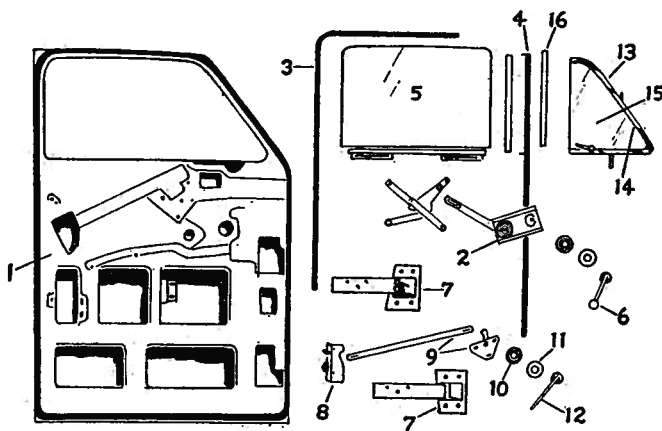

Fig. 6—Front Door—2- & 4-door

\* Opposite side one part number higher

continued



# PLYMOUTH 1946 thru 1953 BODY PARTS

Models P15, 17, 18, 19, 20, 22, 23 and 24. ALL BODY STYLES

## Front Door—continued

1245774—1949-50, 4 dr., 2 dr., 3-pass. cpe., club cpe., conv. cpe., sub. (lower) (right*) ..	3.32
1254792—1949-50, sta. wgn. (right*) ..	4.34
1347652—1951-52, 4 dr., 2 dr., 3-pass. cpe., club cpe., conv. cpe., roadster, spec. club cpe., suburban (upper) (right*) ..	3.32
1347654—1951-52, 4 dr., 2 dr., 3-pass. cpe., club cpe., conv. cpe., roadster, spec. club cpe., suburban (lower) (right*) ..	3.32
1457912—1953, all up. (right*)	2.65
1491054—1953, all low. (right*)	2.65
<b>8 LOCK ASSEMBLY</b>	
944054—1946 to 48, 4 dr. sed. (right*) ..	3.72
944050—1946 to 48, 2 dr., 3 pass. cpe., club cpe. (right*)	3.73
1242693—1949 to 52 (right*) ..	3.80
1432646—1953, exc. spec. cl. cpe. (right*) ..	3.80
1458152—1953, spec. cl. cpe. (right*) ..	3.80
<b>9 REMOTE CONTROL</b>	
998646—1946 to 48 (right*) ..	1.05
1247911—1949 to 52 (right*) ..	1.10
1256444—1949-50, sta. wgn. (right*) ..	1.42
1432778—1953, all (right*) ..	1.10
<b>10 REMOTE CONTROL SPRING</b>	
89796—1946 to 48 ..	.06
849517—1949 to 53 (control lever spring) ..	.15
945962—1949 to 53 (coil spring)	.06
<b>11 ESCUTCHEON</b>	
1152363—1946 to 48, P-15-S ..	.32
1152366—1946 to 48, P-15-C ..	.37
1249025—1949 to 52, 4 dr. deluxe, 2 dr., 3 pass. cpe., club cpe., deluxe suburban ..	.32
†1246819—1949 to 52 (front quarter window sliding glass lock handle) (white) suburban ..	.32
1246031—1949 to 52, 4 dr. spec. deluxe club cpe., spec. deluxe	.47
1256314—1949 to 50, sta. wgn. (inner) ..	.47
1256315—1949-50, sta. wgn. (outer) ..	.74
†1347577—1951-52 (front quarter window sliding glass lock handle) spec. sub. ..	.52
1381279—1951-52, P23-C, 4 dr. sed., club cpe., conv. cpe., spec. club cpe. ..	.47
1249025—1953, regltr. handle ..	.32
<b>12 REMOTE CONTROL HANDLE ASSEMBLY</b>	
987067—1946 to 52 ..	1.10

<b>13 FRONT DOOR VENTILATING WING GLASS FRAME ASSEMBLY</b>	
848856—1946 to 48 (right*) ..	1.94
1303845—1949 (right*) ..	3.04
1303862—1950 to 52, 2 dr. (right*) ..	2.94
1303845—1950 to 52, 4 dr., 3 pass. cpe., club cpe., sub sta. wgn. (right*) ..	3.04
1342488—1950 to 52, conv. cpe.	9.09
1382658—1951-52, spec. club cpe. (right*) ..	7.51
1433312—1953, exc. spec. cl. cpe. (right*) ..	3.00
1477706—1953, spec. cl. cpe. (right*) ..	5.05
<b>14 FRONT DOOR VENT WING WEATHERSTRIP RETAINER</b>	
1304438—1949, 4 dr., 3 pass. cpe., club cpe., suburban (right*) ..	4.16
1249562—1949-50, 2 dr. (right*)	4.16
1254142—1949-50, conv. cpe. (right*) ..	4.16
1304438—1950, 4 dr. (right*) ..	4.16
1304439—1950, 4 dr. (left) ..	4.16
1304439—1950, conv. cpe. (left)	4.16
1431396—1951-52, 2 dr. (right*)	4.53
1431400—1951-52, 4 dr., 3 pass. cpe., club cpe., suburban (right*) ..	4.53
1459188—1953, exc. spec. cl. cpe. (right*) ..	1.75
1459252—1953, spec. cl. cpe. (right*) ..	2.75
<b>15 VENTILATOR GLASS</b>	
848698—1946 to 48 ..	P.O.A.
1245165—1949 to 52, 4 dr., 2 dr., 3 pass. cpe., club cpe., suburban stn. wgn. ..	P.O.A.
1246628—1949-50, conv. cpe. ..	P.O.A.
1249735—1950 to 52, 2 dr. ....	P.O.A.
1342492—1951-52, conv. cpe. ....	P.O.A.
1432837—1953, exc. spec. cl. cpe.	N.P.
1457273—1953, spec. cl. cpe. ....	N.P.
<b>16 FRONT DOOR DIVISION CHANNEL MOLDING</b>	
1296601—1949, 4 dr. sed., 3 pass. cpe., club cpe., suburban sta. wgn. (outer) ..	.63
1296602—1949, 4 dr. sed., 3 pass. cpe., club cpe., suburban sta. wgn. (inner) ..	.68
†1296602—1949, 2 dr. sed. sta. wgn. (inner) ..	.68
†1296602—1949, 2 dr. sed. (outer) ..	.68
1296601—1950 to 52, 4 dr. sed., club cpe., suburban sta. wgn. (inner) ..	.63
1296602—1950 to 52, 4 dr. sed., club cpe., suburban sta. wgn. (outer) ..	.68
1380365—1951-52, conv. cpe. after body No. 4248 Detroit and No. 1290 California (outer) ..	.63
1380364—1951-52, conv. cpe.	

after body No. 4248 Detroit and No. 1290 California (inner) ..	.68
1433315—1953, exc. spec. cl. cpe. (inner) ..	.40
1433315—1953, exc. spec. cl. cpe. (outer) ..	.40
1459087—1953, spec. cl. cpe. (inner) ..	.40
1459456—1953, spec. cl. cpe. (outer) ..	.35

## Rear Door

See Fig. 7

<b>1 DOOR (LESS GLASS TRIM &amp; HARDWARE)</b>	
992025—1946-48 ..	39.51
1249236—1949-50 (right*) ..	54.77
1371603—1951-52 (right*) ..	54.77
1431330—1953 (right*) ..	50.26
<b>2 REAR DOOR WINDOW REGULATOR ASSEMBLY</b>	
897174—1946 to 48 (left*) ..	2.21
1245176—1949 to 52 (right*) ..	4.99
1432742—1953 (right*) ..	4.99
<b>3 REAR DOOR GLASS LOWER CHANNEL ASSEMBLY</b>	
850322—1946 to 48 P-15S (right*) ..	1.37
944612—1946 to 48, P-15C, up to body No. 8240 Los Angeles and No. 15501 Evansville and No. 109828 Detroit (right*)	2.74
850322—1946 to 48, P-15C, after body No. 8240 Los Angeles and No. 15501 Evansville and No. 109828 Detroit (right*) ..	1.37
1245104—1949 to 52 (right*) ..	1.00
1459708—1953 (right*) ..	.83
<b>4 REAR DOOR TOP AND HINGE PILLAR RUN ASSEMBLY</b>	
945428—1946-48 (right*) ..	1.21
1245510—1949-50 ..	1.52
1347538—1951-52 (right*) ..	1.94
1432830—1953 (right*) ..	2.75
<b>5 DOOR GLASS DIVISION CHANNEL RUN</b>	
1246658—1949-52 ..	1.21
<b>6 WINDOW REGULATOR HANDLE ESCUTCHEON SPRING</b>	
89796—1946 to 53 ..	.06
<b>7 WINDOW REGULATOR HANDLE ESCUTCHEON</b>	
1152363—1946-48, P-15S ..	.32
1152366—1946-48, P-15C ..	.37
1246031—1949-50 ..	.47
1381279—1951-52 ..	.47
1249025—1953 ..	.32
<b>8 WINDOW REGULATOR HANDLE</b>	
1152361—1946-48, P-15S ..	1.31
1152364—1946-48, P-15C ..	1.14
1246027—1949-50 ..	1.63
1381279—1951-52 ..	1.63
1248039—1953 ..	2.21

\* Opposite side one part number higher

**BODY PARTS 1946 thru 1953 PLYMOUTH**

**Models P15, 17, P8, 19, 20, 22, 23 and 24. ALL BODY STYLES**

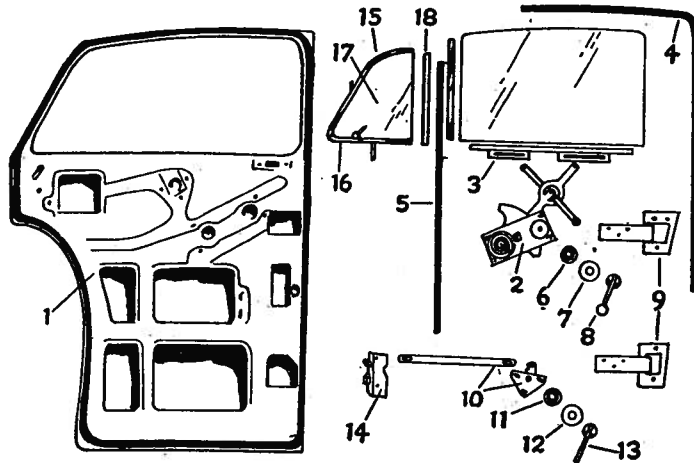

Fig. 7—Rear Door—4-Door Sedans

<b>9 DOOR HINGE</b>	
943410—1946-48 (body half, lower) (right*) .....	.68
943412—1946-48 (door half, lower) (right*) .....	.95
1245586—1949-52, upper (right*) .....	3.00
1245592—1949-50, lower (right*) .....	2.84
1252869—1949-51, stn. wgn. (body half, upper (right*) ..	1.47
1252871—1949-51, stn. wgn. (door half, upper) (right*) ..	1.10
1252875—1949-51, stn. wgn. (body half, lower) (right*) ..	1.47
1252877—1949-51, stn. wgn. (door half, lower) (right*) ..	1.10
1303668—1951-52, lower (right*) .....	2.84
1491060—1953, up. (right*) ..	.....
1491054—1953, low. (right*)..	2.65

<b>10 DOOR LOCK REMOTE CONTROL ASSEMBLY</b>	
1247840—1949-52 (right*) ....	1.05
1432772—1953 (right*) .....	.....

<b>11 REMOTE CONTROL LEVER SPRING</b>	
849517—1949 to 53 .....	.15

<b>12 DOOR REGULATOR AND REMOTE CONTROL HANDLE ESCUTCHEON</b>	
1152363—1946-48, window regulator .....	.32
1152366—1946-48, remote control .....	.37
1249025—1949 to 53, deluxe, club cpe. deluxe .....	.32
1246031—1949-52, spec. deluxe, club cpe. spec. deluxe .....	.47

<b>13 DOOR LOCK REMOTE CONTROL HANDLE</b>	
987067—1946 to 53 .....	1.10
<b>14 LOCK ASSEMBLY</b>	
1245915—1949-52 (right*) ....	3.80
1432676—1953 (right*) .....	3.80
<b>15 VENT WIND GLASS FRAME</b>	
1303866—1949 (right*) .....	2.47
1303866—1950-52 (right*) ...	2.47
1433800—1953 (right*) .....	3.30
<b>16 VENT WING WEATHERSTRIP RETAINER</b>	
1245242—1949-50 (right*)....	4.16
1348366—1951-52 (right*) ...	4.16
1433994—1953 (right*) .....	4.55

<b>17 VENT WING GLASS</b>	
1245168—1949-52 .....	P.O.A.
1457178—1953 .....	N.P.
<b>18 DIVISION CHANNEL MOLDING</b>	
1296601—1949 (outer) .....	.63
1296602—1949 (inner) .....	.68
1296602—1950-52 (outer) ....	.68
1296601—1950-52 (inner).....	.63
1433314—1953 (inner) .....	.35
1433315—1953 (outer) .....	.40

**Body Moldings, Wheels and Glass**

*Convertible and Belvedere*

See Fig. 8

<b>1 FRONT BUMPER FACE BAR</b>	
1115456—1946 to 48.....	25.14
1134371—1949 .....	32.95
1319566—1950 .....	32.95
1321712—1951-52 .....	32.85
1329450—1953 .....	32.95

<b>2 FRONT FENDER ASSEMBLY</b>	
1065888—1946 to 48 (right*)..	29.95
1309271—1949 (right*) .....	27.94
1335424—1950 (right*) .....	27.94
1346508—1951-52 (right*) ....	27.94
1494315—1953 (right*) .....	27.94

<b>3 FRONT FENDER NAME PLATE</b>	
1148645—1946 to 48, P-15-S (hood side) .....	1.28
1148646—1946 to 48, P-15-C (hood size).....	1.48
1065759—1946 to 48 (center panel) .....	1.48
1253713—1949-50, spec. deluxe.	1.38
1253712—1949-50, deluxe .....	1.15
1373037—1951-52 .....	2.10
1456100—1953, Cambridge ....	2.10
1456101—1953, Cranbrook ...	2.10

*continued*

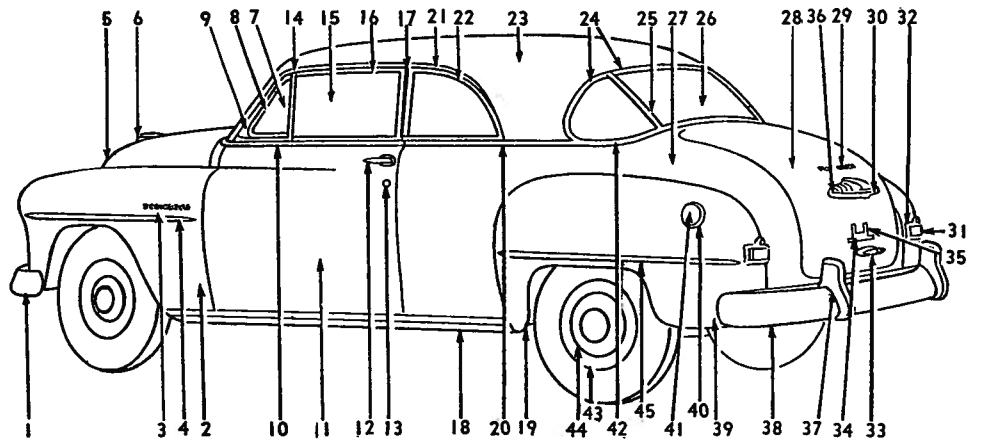

Fig. 8—Body Moldings, Wheels and Glass

\* Opposite side one part number higher

# PLYMOUTH 1946 thru 1953 BODY PARTS

Models P15, 17, 18, 19, 20, 22, 23 and 24. ALL BODY STYLES

## Body Moldings, Wheels and Glass—continued

<b>4 FRONT FENDER MOLDING</b>		<b>12 DOOR OUTSIDE HANDLE</b>		1248600—1949 to 52, rear	
1065541—1946 to 48 (right*)..	2.90	1161290—1946 to 48 (right*)..	2.56	(right*) .....	1.32
1298328—1949 (right*) .....	3.04	1247630—1949 to 52.....	3.11	1477926—1953, conv. ....	3.75
1335572—1950 (hood) (right*)	1.19	1433104—1953 .....	2.80	<b>21 ROOF SIDE RAIL RETAINER</b>	
1335335—1950 (right*) .....	3.92	<b>13 LOCK CYLINDER &amp; KEYS</b>		1381368—1951-52 (right*) ....	3.19
1346774—1951-52 .....	3.02	<b>PACKAGE</b>		1459036—1953, spec. cpe.	
1456227—1953 (right*) .....	3.90	992586—1946 to 48.....	1.89	(right*) .....	
<b>5 TOP HOOD PANEL</b>		1163772—1946 to 48, water-		<b>22 QUARTER WINDOW GLASS FRAME</b>	
1158822—1946 to 48 .....	37.45	proof type .....	2.00	1247560—1949 to 52 (right*)..	21.82
1239965—1949 .....	37.45	1315510—1949 to 52.....	2.21	1458726—1953, conv. (front)..	7.25
1335263—1950 .....	37.45	<b>14 FRONT BODY PILLAR</b>		1458053—1953, conv. (up. &	
1346502—1951 .....	37.45	<b>WEATHERSTRIP</b>		rear) .....	5.50
<b>6 TOP HOOD ORNAMENT</b>		1248514—1949 to 52 (right*)..	2.97	1458690—1953, spec. cpe.	
1065766—1946 to 48 .....	5.95	1492208—1953, conv. (right*)..	2.06	(front) .....	7.25
1335472—1949 .....	5.95	1458176—1953, spec. cpe.		1458829—1953, spec. cpe. (up.	
1335472—1950 .....	5.95	(right*) .....	17.75	& rear) .....	5.50
1373393—1951 .....	5.95	<b>15 FRONT DOOR GLASS</b>		<b>23 ROOF PANEL ASSEMBLY</b>	
1456316—1952 .....	4.75	849011—1946 to 48.....	P.O.A.	1249214—1949 .....	104.85
1456363—1953 .....	4.75	1246635—1949 (right*) .....	P.O.A.	1303315—1950 .....	32.59
<b>7 FRONT DOOR VENTILATING WING</b>		1246635—1950 .....	P.O.A.	1367933—1951 .....	104.85
<b>GLASS</b>		1381293—1951-52 .....	P.O.A.	1367932—1952 .....	104.85
848698—1946 to 48.....	P.O.A.	1433359—1953, conv. ....	N.P.	1497547—1953, spec. cpe. ....	
1245165—1949 .....	P.O.A.	1433358—1953, spec. cpe. ....	N.P.	1491080—Right upper .....	1.95
1249735—1950 to 52.....	P.O.A.	<b>16 DOOR GLASS FRAME</b>		1491804—Right lower .....	1.95
1457272—1953, conv. ....	N.P.	1246631—1949-50 (right*) ....	20.43	<b>24 REAR WINDOW OUTSIDE MOLDING</b>	
1457273—1953, spec. cpe. ....	N.P.	1246631—1951, up to body No.		1247464—1949 .....	3.04
<b>8 FRONT DOOR VENTILATING WING</b>		4248 Detroit & 1290 Cali-		1337049—1950, upper (right)..	1.49
<b>GLASS FRAME</b>		fornia (right*) .....	20.43	1342648—1950, upper (left)...	1.47
848856—1946 to 48 (right*)...	1.94	1381294—1951-52, after body		1337088—1950, lower .....	1.94
1303862—1949 (right*) .....	2.94	No. 4248 Detroit & 1290 Cali-		1338100—1950, lower corner	
1303862—1950 to 52 (right*)..	2.94	fornia (upper) (right*) ....	4.94	(right*) .....	.95
1477704—1953, conv. (right*)..	5.05	1381288—1951-52, after body		1381364—1951-52, side (right*)	1.57
1477706—1953, spec. cpe.		No. 4248 Detroit & 1290 Cali-		1381901—1951-52, upper .....	1.94
(right*) .....	5.05	fornia (rear) (right*) .....	4.89	1382433—1951-52, lower center.	2.01
<b>9 DOOR VENT WING FRAME</b>		1433737—1953, conv. (up.)...	4.05	1382434—1951-52, lower side	
1246616—1949-50 (right*)....	23.76	1433630—1953, conv. (rear		(right*) .....	1.54
1368070—1951-52, up to body		right*) .....	4.40	1491080—1953, spec. cpe. (up.	
No. 4248 Detroit and 1290		1433738—1953, spec. cpe. (up.)	4.05	right*) .....	1.95
California (right*) .....	23.76	1433632—1953, spec. cpe. (rear		1491804—1953, spec. cpe. (low.	
1381260—1951-52, after body		right*) .....	4.40	right*) .....	1.95
No. 4248 Detroit and 1290		<b>17 QUARTER WINDOW TO DOOR</b>		<b>25 REAR WINDOW DIVISION BAR</b>	
California (right*) .....	28.29	<b>GLASS WEATHERSTRIP</b>		1381548—1951-52 (right*)....	2.17
1477744—1953, conv. (right*)..	17.95	1247998—1949 to 52 (right*)..	3.75	<b>26 REAR WINDOW GLASS</b>	
1477600—1953, spec. cpe.		1459274—1953, conv. (right*)..	3.05	901818—1946 to 48.....	P.O.A.
(right*) .....	17.95	<b>18 BODY SIDE SILL MOLDING</b>		1245359—1949 .....	P.O.A.
1431068—1951-52, spec. club		1149182—1946 to 48 (right*)..	8.41	1337037—1950 .....	P.O.A.
cpe. (right*) .....	16.41	1249454—1949 (right*).....	8.41	1367262—1951-52 .....	P.O.A.
<b>10 FRONT DOOR OUTSIDE FINISH</b>		1249454—1950, use w/o fender		1458126—1953, spec. cpe. ....	N.P.
<b>MOLDING</b>		shield (right*) .....	8.41	<b>27 QUARTER PANEL</b>	
1065828—1946 to 48.....	2.05	1341130—1950, use w/fender		1338994—1949, club cpe.	
1246646—1949-50 (right*) ....	2.57	shield (right*) .....	8.09	(right*) .....	76.74
1349154—1951-52 (right*) ....	2.57	1349102—1951-52, use w/o fen-		1338972—1949, conv. cpe.	
<b>11 FRONT DOOR</b>		der shield (right*) .....	8.53	(right*) .....	78.94
976892—1946 to 48 (right*)...	42.89	1349118—1951-52, use w/fender		1338994—1950, club cpe.	
1249206—1949, conv. cpe.		shield (right*) .....	8.26	(right*) .....	76.74
(right*) .....	59.29	<b>19 REAR FENDER WELT</b>		1338972—1950, conv. cpe.	
1249198—1950, club cpe.		975973—1946 to 48.....	2.34	(right*) .....	78.94
(right*) .....	53.65	1302359—1949 to 53 .....	30	1367596—1951-52, club cpe.	
1249198—1950 (right*) .....	53.65	<b>20 QUARTER PANEL OUTSIDE FINISH</b>		(right*) .....	76.74
1348268—1951-52 (right*) ....	59.29	<b>MOLDING</b>		1380518—1951-52, conv. cpe.	
1431320—1953 (right*) .....	61.75	1248598—1949 to 52, front		(right*) .....	78.94
		(right*) .....	1.37	1431050—1951-52, spec. cub cpe.	
				(right*) .....	78.94

\* Opposite side one part number higher

# BODY PARTS 1946 thru 1953 PLYMOUTH

Models P15, 17, 18, 19, 20, 22, 23 and 24. ALL BODY STYLES

1496782—1953, conv. (right*)..	N.P.
1458116—1953, spec. cpe. (right*) .....	N.P.
<b>28 LUGGAGE COMPARTMENT LID</b>	
1245058—1949, club cpe.....	39.21
1303177—1949, club cpe.....	39.21
1477816—1950-51 .....	39.21
1477816—1952 .....	39.21
1431094—1953 .....	39.25
<b>29 NAME PLATE</b>	
1248374—1949 .....	1.27
1338836—1950 .....	2.17
1331643—1951 .....	1.98
1473317—1952 .....	2.24
1477998—1953 (Plymouth)....	1.15
<b>30 LICENSE LAMP LENSE BEZEL</b>	
1244779—1949 .....	2.15
1343283—1950 to 52.....	1.89
1383210—1953, housing .....	1.15
<b>31 TAIL LAMP LENS</b>	
1154325—1946 to 48.....	.83
1300567—1949 (right*).....	2.17
1340146—1950 to 52 (right*)..	1.12
1436451—1953 .....	1.85
<b>32 TAIL LAMP SHELL</b>	
1154324—1946 to 48 .....	3.74
1343109—1950 to 52 (right*)..	3.31
<b>33 DECK AND LUGGAGE COMPARTMENT LID HANDLE</b>	
973557—1946 to 48.....	1.90
1244755—1949 .....	2.08
1478494—1950 .....	5.25
1478494—1951-52, w/ornament	5.25
1347795—1951-52, w/o ornament .....	2.66
1477746—1953 .....	3.95
<b>34 REAR LICENSE BRACKET</b>	
1149857—1946 to 48 .....	.70
1302836—1949 .....	.42
1302836—1950 to 52.....	.42
1473691—1953 .....	.80
<b>35 REAR LICENSE BRACKET CLAMP</b>	
1149877—1946 to 48.....	.10
1244698—1949 to 52.....	.10
1473695—1953 .....	.15
<b>36 LICENSE LAMP SHELL OR HOUSING</b>	
938987—1946 to 48.....	5.46
1343280—1950 to 52 .....	13.85
1383210—1953 .....	1.15
<b>37 REAR BUMPER BUFFER PLATE</b>	
1141807—1949 (left*).....	5.91
1135010—1949 (center) .....	4.95
1319587—1950 (right*).....	5.74
1325160—1951-52, P22 (right*)	5.74
1323959—1951-52, P23 (right*)	5.74
1483149—1953 (right*) .....	6.35

<b>38 REAR BUMPER FACE BAR</b>	
954949—1946 to 48.....	23.74
1314668—1949 .....	34.17
1319567—1950 .....	34.17
1321730—1951-52 .....	34.95
1329457—1953 .....	30.50
<b>39 REAR FENDER</b>	
1148953—1946 to 48 (right*)..	18.22
1243452—1949 (right*).....	18.22
1364829—1950 (right*) .....	18.22
1364829—1951-52 (right*) .....	18.22
<b>40 FUEL TANK FILLER TUBE FENDER HOLE COVER</b>	
657625—1946 to 52.....	.47
1487073—1953 .....	.60
<b>41 FUEL TANK FILLER TUBE CAP</b>	
384982—1946 to 52.....	.80
1401504—1953 .....	.85
<b>42 ROOF PANEL OUTSIDE FINISH MOLDING JOINT COVER</b>	
1246219—1949-50 .....	.32
1342651—1950 (window molding) .....	.22
1381300—1951-52, lower corner (right*) .....	1.10
1367782—1953, upper .....	.22
1491801—1953, low. cor. ....	.45
<b>43 WHEEL COVER</b>	
1142852—1949 .....	4.58
1316723—1950 .....	7.50
1326891—1951-52 .....	7.50
1408539—1953 .....	7.50
<b>44 WHEEL</b>	
1320042—1949 .....	9.83
1320042—1950 to 53 .....	9.83
<b>45 REAR FENDER MOLDING</b>	
1246225—1949 (right*).....	3.59
1333836—1950 .....	3.95
1349206—1951-52 (right*)....	4.31
1477926—1953 .....	3.75

## Body Moldings, Wheels and Glass

Suburban  
See Fig. 9

<b>1 MEDALLION HOOD</b>	
1299362—1949 .....	2.05
1335317—1950 .....	1.72
1347185—1951 .....	1.72
1456324—1952 .....	1.00
1456284—1953 .....	1.00
<b>2 ORNAMENT HOOD</b>	
1335472—1949 .....	5.95
1335472—1950 .....	5.95
1373393—1951 .....	3.74
1456316—1952 .....	4.75
1456363—1953 .....	4.75
<b>3 MOLDING HOOD TOP</b>	
1298932—1949-1950 .....	2.22
1347248—1951 .....	2.10
1456283—1952 .....	1.23
<b>4 BAR—WINDSHIELD DIVISION</b>	
1246405—1949-50 .....	1.09
1367422—1951-52 .....	1.91
<b>5 MOLDING WINDSHIELD OUTER</b>	
1246424—1949-50, right .....	2.16
1432674—1951-52, right .....	3.31
1477568—1953, upper .....	1.85
1477718—1953, side (right*)..	2.50
1477569—1953, lower .....	2.00
<b>6 WINDSHIELD GLASS</b>	
1245188—1949-50 .....	P.O.A.
1367307—1951-52 .....	P.O.A.
1432404—1953 .....	N.P.
<b>7 FRAME VENT WING</b>	
1303845—1949 (right*) .....	3.04
1303845—1950-51 (right*) .....	3.04

continued

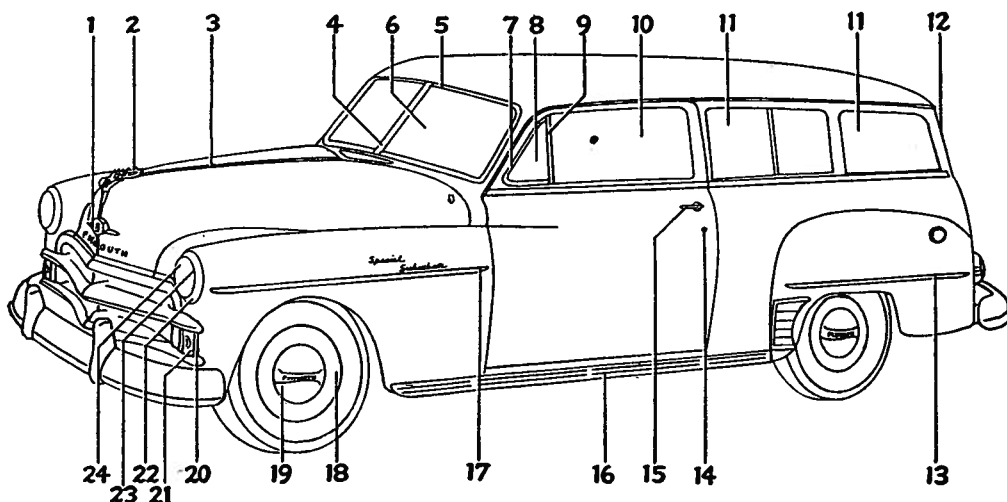

Fig. 9—Body Moldings, Wheels and Glass

\* Opposite side one part number higher

# PLYMOUTH 1946 thru 1953 BODY PARTS

Models P15, 17, 18, 19, 20, 22, 23 and 24. ALL BODY STYLES

## Body Moldings, Wheels and Glass—continued

<b>8 GLASS VENT WING</b>	
1245165—1949-52 .....	P.O.A.
1432837—1953 .....	N.P.
<b>9 MOLDING VENT WING DIVISION OUTER</b>	
1296601—1949 to 52 .....	.63
1433314—1953 .....	.35
<b>10 DOOR GLASS</b>	
1245625—1949 to 52 .....	P.O.A.
1432544—1953 .....	N.P.
<b>11 GLASS, REAR, QUARTER SLIDING</b>	
1246398—1949 to 52 .....	P.O.A.
1432796—1953 .....	N.P.
<b>GLASS, REAR, QUARTER STATIONARY</b>	
1246435—1950 to 52 .....	P.O.A.
1246362—1949 .....	P.O.A.
1432797—1953 .....	N.P.
<b>12 GLASS UPPER TAIL GATE</b>	
1254045—1949 to 50 .....	P.O.A.
1338878—1951-52 .....	P.O.A.
1433080—1953 .....	N.P.
<b>13 MOLDING REAR FENDER</b>	
1246225—1949 (right) .....	3.59
1334111—1950 .....	4.14
1368042—1951-52 .....	4.08
1458111—1953 .....	3.20
<b>14 CYLINDER DOOR LOCK</b>	
1315510—1949 to 52 .....	2.21
<b>15 HANDLE FRONT DOOR</b>	
1246408—1949 to 52 (right*) ..	2.94
1433104—1953 .....	2.80
<b>16 MOLDING BODY SIDE SILL</b>	
1249454—1949 (right*) .....	8.41
1249462—1950 (right*) .....	7.83
1349114—1951 (right*) .....	7.99
<b>17 MOLDING FRONT FENDER</b>	
1298328—1949 (right*) .....	3.04
1335335—1950 (right*) .....	3.92
1346774—1951-52 .....	3.02
1456227—1953 .....	3.90
<b>18 WHEEL TRIM RING</b>	
1142852—1949 to 52 .....	4.58
<b>18 WHEEL COVER (Stainless Steel)</b>	
1316723—1950 .....	7.50
1326891—1951-52 .....	7.50
<b>19 HUB CAPS</b>	
1142878—1949-50 .....	3.90
1324128—1951-52 .....	3.90
1485743—1953 .....	2.95
1408539—1953 .....	7.50
<b>20 BEZEL PARKING LIGHT</b>	
1297815—1949 (right) .....	2.55
1343305—1950, retainer, outer (right) .....	1.55

1343301—1950, retainer inner (right) .....	1.45
1345610—1951 (right) .....	3.75
1440097—1953 .....	3.90
<b>21 LENS, PARKING LIGHT</b>	
1297789—1949 .....	.72
1340270—1950 .....	1.03
1345479—1951-52 .....	1.03
1440098—1953 .....	1.03
<b>22 HEAD LAMP DOOR</b>	
1239411—1949 to 52 .....	2.50
1345670—1953, chrome .....	3.95
<b>23 RING—BULB RETAINING</b>	
946942—1949 to 53 .....	1.82
<b>24 BULB—UNIT SEAL BEAM</b>	
1297667—1949 to 53 .....	1.95
<b>MOLDING, DOOR, OUTSIDE FINISH</b>	
1349154—1951-52 (right), special sub. ....	2.57
<b>MOLDING, QUARTER PANEL</b>	
1367670—1951-52 (right), special sub. ....	3.52
<b>MOLDING, FRONT QUARTER WINDOW GLASS DIVISION</b>	
1367780—1951-52, special sub. ....	.32

<b>2 COWL SIDE PANEL ASSEMBLY</b>	
943558—1946 to 48 (right*) ..	12.35
1247866—1949-50 (right*) ....	7.89
1349126—1951-52 (side) conv. (right*) .....	7.89
1348744—1951-52, upper .....	55.19
1381428—1951-52, Belvedere (right*) .....	20.97
1459698—1953, conv. (right*) ..	19.95
1477650—1953, spec. cpe. (right*) .....	19.95
<b>3 DOOR PANEL</b>	
977504—1946 to 48 (right*) ..	12.55
1304452—1949 (right*) .....	11.22
1381950—1950 to 53 (right*) ..	13.30
<b>4 BODY OUTER SIDE SILL</b>	
1245890—1949-50 (right*) ....	6.10
1349156—1951-52 (right*) ....	6.10
<b>5 BODY INNER SILL</b>	
1247854—1949-50 w/clinch nut (right*) .....	7.20
1249272—1950 to 52 (right*) ..	7.47
1433134—1953, conv. (right*) ..	9.95
<b>6 UPPER COWL PANEL ASSEMBLY</b>	
1247864—1949-50 .....	47.30
1348744—1951-52 .....	55.19
1497543—1953, conv. ....	72.50
1497548—1953, spec. cpe. ....	41.75
<b>7 ROOF REPAIR PANEL</b>	
1303315—1949 .....	32.59
1431037—1951-52 .....	143.75
1497547—1953, spec. cpe. ....	143.75
<b>8 REAR QUARTER PANEL</b>	
1338972—1949 (right*) .....	78.94
1338972—1950 (right*) .....	73.94

## Body Sheet Metal and Fuel Tank

Conv. & Belvedere  
See Fig. 10

<b>1 DASH PANEL</b>	
1245011—1949-50 .....	11.86
1367883—1951-52 .....	11.86

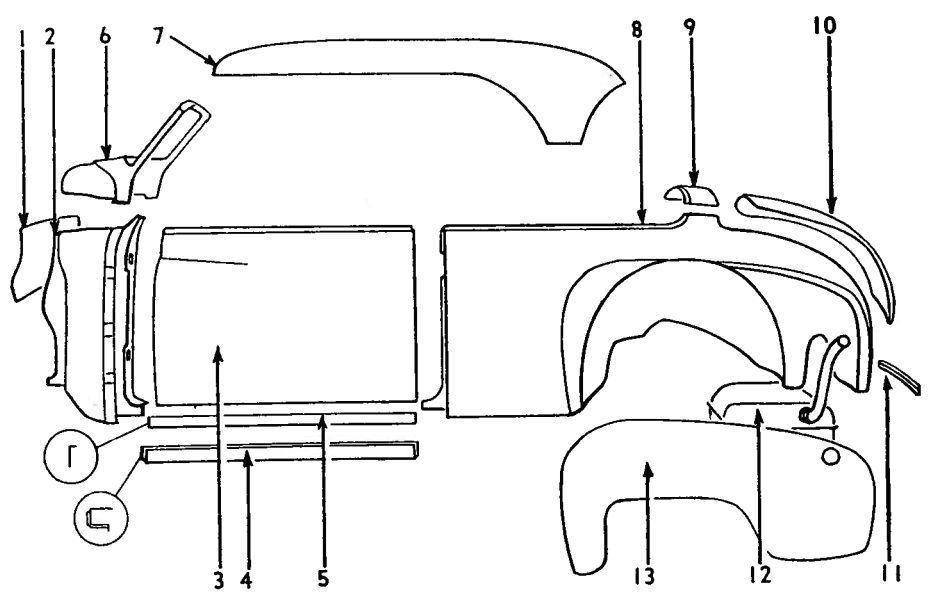

Fig. 10—Body Sheet Metal and Fuel Tank

\* Opposite side one part number higher

**BODY PARTS 1946 thru 1953 PLYMOUTH**

**Models P15, 17, 18, 19, 20, 22, 23 and 24. ALL BODY STYLES**

1380518—1951-52 (right*) ...	73.94
1496782—1953, conv. (right*)..	79.25
1458116—1953, spec. cpe. (right*) .....	....

**9 TRUNK COMPARTMENT  
OPENING PANEL**

1248421—1949, upper .....	10.51
1342015—1950 .....	12.09
1380281—1951-52, conv. ....	12.09
1381210—1951-52, Belvedere ..	15.50
1432916—1953, spec. cpe. ....	9.85
1459571—1953, conv. ....	17.50

**10 DECK LID**

1245058—1949, club cpe. ....	39.21
1303177—1949, conv. cpe. ....	33.21
1477816—1950, conv. cpe. ....	39.21
1477816—1951, conv. cpe. & spec. club cpe. ....	39.21
1477816—1952, conv. cpe. & spec. club cpe. ....	39.21
1431094—1953 .....	39.25

**11 REAR END PANEL**

1303085—1949 to 52, conv. cpe.	<b>6.88</b>
--------------------------------	-------------

**12 FUEL TANK**

1138587—1949 to 52 .....	16.25
1483601—1953 .....	N.P.

**13 REAR FENDER**

1243452—1949 .....	18.22
1364829—1950 .....	18.22
1364829—1951-52 .....	18.22

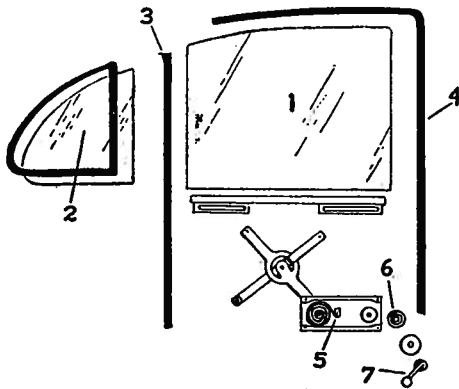

Fig. 11—Rear Quarter Window, Tudor Sedan

**Rear Quarter Window**

Tudor Sedan

See Fig. 11

**1 GLASS, QUARTER WINDOW, FRONT**

848677—1946 to 48.....	P.O.A.
1249056—1949 to 52.....	P.O.A.
1432641—1953 .....	N.P.

**2 GLASS, QUARTER WINDOW, REAR**

1249032—1949-50 .....	P.O.A.
1367924—1951-52 .....	P.O.A.
1433322—1953 .....	N.P.

**3 RUN., REAR QUARTER WINDOW,  
REAR**

944866—1946 to 48.....	2.21
1249087—1949 to 52.....	.68

**4 RUN., REAR QUARTER WINDOW,  
FRONT**

944866—1946 to 48.....	2.21
1249077—1949 to 52.....	1.47
1432832—1953 (right*) .....	2.55

**5 REGULATOR, QUARTER WINDOW**

897173—1946 to 48 (right)....	2.21
1249122—1949 to 52 (right)...	4.99
1457080—1953 (right*) .....	4.99

**6 SPRING, REGULATOR HANDLE**

89796—1946 to 48 .....	.06
1256337—1949 to 53 .....	.58

**7 HANDLE, QUARTER WINDOW  
REGULATOR**

1152361—1946 to 48.....	1.31
1246027—1949 .....	1.63
1248039—1950 to 53 .....	2.21

1381447—1951-52, special club cpe. ....	10.85
1458926—1953, 2 & 4 dr. ....	6.34
1458927—1953, 3 cpe. ....	5.86
1458130—1953, spec. cpe. ....	11.43
1458924—1953, cl. cpe. ....	5.86

**2 REAR WINDOW GLASS**

848054—1946 to 48, fordor....	P.O.A.
872382—1946 to 48, 3-pass. cpe.	P.O.A.
901818—1946 to 48, club cpe....	P.O.A.
1245162—1949, fordor.....	P.O.A.
1245359—1949, club cpe.....	P.O.A.
1245231—1949, 3-pass. cpe....	P.O.A.
1337038—1950 to 52, 3-pass. cpe. ....	P.O.A.
1337036—1950, fordor .....	P.O.A.
1337037—1950, club cpe.....	P.O.A.
1367516—1951, fordor .....	P.O.A.
1367262—1951-52, club cpe....	P.O.A.
1381410—1951-52, special club cpe. (right*) .....	P.O.A.
1381411—1951-52, special club cpe. (left*) .....	P.O.A.
1381412—1951-52, special club cpe. (center) .....	P.O.A.
1431799—1953, 2 & 4 dr .....	N.P.
1432455—1953, 3 cpe., cl. cpe...	N.P.
1458126—1953, spec. cpe. ....	N.P.

**3 MOLDING, REAR WINDOW, OUTSIDE**

1245960—1949, fordor .....	2.94
1247464—1949, club cpe.....	3.04
1338680—1950-52, 3 pass. cpe., upper (right*) .....	1.47
1338681—1950-52, 3 pass. cpe., lower .....	1.94
1337048—1950, fordor, upper (right*) .....	1.47
1337087—1950, fordor, lower ..	1.94
1337049—1950, club cpe., upper (right*) .....	1.47
1337088—1950, club cpe., lower	1.94
1338682—1950-52, 3 pass cpe., lower corner (right*).....	.95
1337090—1950, fordor, lower corner (right*) .....	.95
1338100—1950, club cpe., lower corner (right) .....	.95
1368080—1951-52, fordor upper (right*) .....	1.74
1368173—1951-52, fordor, lower	2.99
1368148—1951-52, club cpe., up- per (right*) .....	1.74
1368167—1951-52, club cpe., lower) .....	2.99
1433288—1953, 4 dr. up. (right*) .....	1.95
1492210—1953, 4 dr. low. (right*) .....	1.75
1433920—1953, 2 dr., cl. cpe. up. & sides .....	1.95
1492236—1953, 2 dr., cl. cpe. (right*) .....	1.75
1491080—1953, spec. cpe. up. (right*) .....	1.95
1491804—1953, spec. cpe. low. (right*) .....	1.95

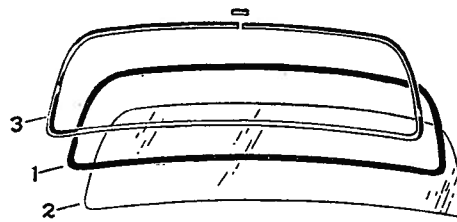

Fig. 12

**Rear Window Assembly**

See Fig. 12

**1 REAR WINDOW WEATHERSTRIP**

848291—1946 to 48, fordor...	2.79
851786—1946 to 48, club cpe..	3.04
934683—1946 to 48, 3-pass cpe.	3.04
1246851—1949, 3-pass cpe.....	5.15
1245163—1949, club cpe., S. de- luxe .....	3.79
1249010—1949, club cpe., de- luxe .....	5.26
1247517—1949, fordor, S. de- luxe .....	3.57
1249011—1949, fordor, deluxe.	5.15
1337033—1950, fordor .....	4.04
1337034—1950, 3-pass. cpe. & club cpe. ....	3.79
1337034—1951-52, 3-pass cpe..	3.79
1431116—1951-52, fordor .....	5.41
1431117—1951-52, club cpe....	5.05

\* Opposite side one part number higher

# PLYMOUTH 1946 thru 1953 BODY PARTS

Models P15, 17, 18, 19, 20, 22, 23 and 24. ALL BODY STYLES

## Convertible Coupe Door

See Fig. 13

<b>1 DOOR ASSEMBLY SHELL</b>	
977271—1946 to 48 (right)...	45.42
1249206—1949-50 (right).....	59.29
1348268—1951-52 (right).....	59.29
1431320—1953 (right*) .....	61.75
<b>2 REGULATOR DOOR WINDOW</b>	
954558—1946 to 48 (right)....	2.38
1249560—1949 (right) .....	1.42
1249650—1950 to 52 (right)...	6.75
1457206—1953 (right*) .....	6.75
<b>3 DOOR GLASS</b>	
945344—1946 to 48.....	P.O.A.
1246635—1949-50 .....	P.O.A.
1381293—1951-52 .....	P.O.A.
1433359—1953 .....	N.P.
<b>4 REGULATOR HANDLE</b>	
1152364—1946 to 48.....	1.14
1246027—1949-50 .....	1.63
1381278—1951-52 .....	1.63
1248039—1953 .....	2.21
<b>5 REGULATOR HANDLE SPRING</b>	
89796—1946 to 53 .....	.06
<b>6 DOOR LOCK ASSEMBLY</b>	
944050—1946 to 48 .....	3.73
1242693—1949 to 52.....	3.80
1458152—1953 (right*) .....	3.80
<b>7 REMOTE CONTROL ASSEMBLY</b>	
998646—1946 to 48 (right)....	1.05
1247911—1949 to 52 (right)...	1.10
1432778—1953 (right*) .....	1.10
<b>8 DOOR HINGE, UPPER</b>	
944017—1946 to 48 (right)....	2.25
1347652—1949-50 (right) .....	3.32
1347652—1951-52 (right).....	3.32
1457912—1953 (right*) .....	2.65

<b>9 DOOR HINGE, LOWER</b>	
943869—1946 to 48 (right)...	2.25
1245774—1949-50 (right).....	3.32
1347654—1951-52 (right).....	3.32
1491054—1953 (right*) .....	2.65
<b>10 DOOR, INSIDE OPENING HANDLE</b>	
987067—1946 to 53 .....	1.10
<b>11 ESCUTCHEON PLATE</b>	
1152366—1946 to 48.....	.37
1246031—1949-50 .....	.47
1381279—1951-52 .....	.47
1249025—1953 .....	.32
<b>12 FRAME DOORVENT WING</b>	
945280—1946 to 48 (right) ..	21.55
1246616—1949-50 (right) .....	23.76
1368070—1951-52 (right).....	23.76
1477744—1953 (right*) .....	17.95
<b>13 VENT WING FRAME</b>	
944872—1946 to 48 (right*)..	10.51
1303870—1949 (right*) .....	9.09
1342488—1950-51* (right*)...	9.09
1381266—1951-52† (right*)...	7.51
1477704—1953 (right*) .....	5.05
* Up to Body No. 4248.	
† After Body No. 4248.	
<b>14 VENT WING GLASS</b>	
945344—1946 to 1948.....	P.O.A.
1246628—1949-50 .....	P.O.A.
1342492—1951-52 .....	P.O.A.
1457272—1953 .....	N.P.
<b>15 FRAME, DOOR GLASS</b>	
970218—1946 to 48 (right*)..	P.O.A.
1246631—1949-50 (right*) .....	P.O.A.
1246631—1951* (right*).....	P.O.A.
1381294—1952† (upper).....	P.O.A.
1433737—1953, up. ....	N.P.
1433630—1953 (rear right*)..	N.P.
* Up to Body No. 4248.	
† After Body No. 4248.	

## Rear Luggage Compartment and Rear Bumper

See Fig. 14

<b>1 REAR BUMPER FACE BAR</b>	
954949—1946 to 48 .....	23.74
1311975—1949, 2 dr. sed. ....	30.50
1311605—1949, suburban .....	30.50
1137683—1949, 3 pass. cpe. ...	28.65
1314668—1949 (except 2d. sed. 3 pass. cpe., sub. & sta. wgn.)	34.17
1312234—1949, sta. wgn. (right*) .....	16.95
1319589—1950, 2 dr. sed. ....	34.95
1319567—1950, P19, 3 pas. cpe. (P20 except stn. wgn.) .....	34.17
1319666—1950, P19 sub., P20 stn. wgn. ....	33.50
1324026—1951-52, 2 dr. sed. ...	34.95
1321730—1951-52, P22 3 pass. cpe. (P23) .....	34.95
1324031—1951-52, P22 sub. ...	34.95
1329457—1953, exc. sub. ....	34.95
1405241—1953, sub. ....	34.95
<b>2 REAR BUMPER BUFFER PLATE</b>	
1313353—1949, P18 sta. wgn...	7.20
1141808—1949, P17, P18 (except sub. & stn. wgn.) (left*)	5.91
1135010—1949, P17, sub. ....	4.95
1135010—1949, P17, P18 (except sub. & stn. wgn.) (center) .....	4.95
1319587—1950, P19, P20 (except sub. & stn. wgn.) (right*) .....	5.74
1320687—1950, P19, P20 sub. & stn. wgn. (right*) .....	5.50
1325160—1951-52, P22 (right*)	5.74
1323959—1951-52, P23 (right*)	5.74
1483149—1953, exc. sub. (right*) .....	6.35
1405253—1953, sub. ....	14.50
<b>3 REAR BUMPER STONE DEFLECTOR</b>	
1152482—1946 to 48 (P-15S up to Serial No. 15156180 & P-15C to No. 11498359) .....	7.65
953836—1946 to 48 (P-15S after Serial No. 15156180 & P-16C after No. 11498359) .....	8.70
1314679—1949, P18 (exc. 2 dr. sed., 3 cpe., sub. & stn. wgn.)	7.65
1312003—1949, P17, 2 dr. & sed.	8.70
1138755—1949, P17, 3 pass. cpe.	7.65
1341367—1949, P17, sub. ....	13.75
1312527—1949, P18, stn. wgn. (right*) .....	4.83
1319582—1950, P19, 3 pass. cpe. P20 (exc. stn. wgn.) .....	7.65
1319597—1950, P19, 2 dr. sed. ...	7.65
1341367—1950, P19, sub. ....	13.75
1319650—1950, P20, stn. wgn. (right*) .....	4.83
1324052—1951-52, P22, 2 dr. sed. ....	7.65
1349279—1951-52, P22, 3 pass. cpe. P23 .....	7.65
1368276—1951-52, P22, sub. ...	13.75
1402896—1953, exc. sub. ....	7.65
1407799—1953, sub. ....	13.75

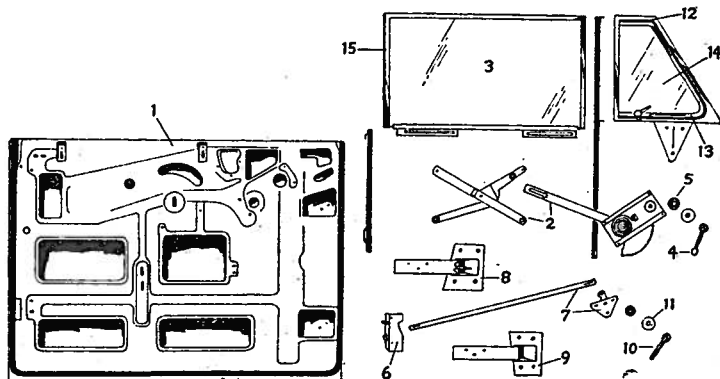

Fig. 13—Door, Convertible

\* Opposite side one part number higher

**BODY PARTS 1946 thru 1953 PLYMOUTH**

**Models P15, 17, 18, 19, 20, 22, 23 and 24. ALL BODY STYLES**

**4 REAR BUMPER FACE BAR SUPPORT**

953809—1946 to 48 (right) ...	4.05
1314669—1949 (exc. 2 dr. sed., 3 cpe., sub. & stn. wgn. ....	11.50
1311887—1949, 2 dr. ....	10.78
1137690—1949, 3 pass. cpe. ....	10.78
1319568—1950, exc. 2 dr. sed. ...	11.50
1319590—1950, 2 dr. sdn. ....	11.50
1321731—1951, exc. 2 dr. sdn. ...	11.50
1403836—1951, 2 dr. sed. (right*) .....	4.53
1324032—1951, sub. stn. wgn. ...	11.50
1403864—1953, exc. sub. (right*) .....	1.65
1405249—1953, sub. ....	11.50

**5 BEZEL TAIL LAMP**

1154324—1946 to 48 .....	3.74
1339867—1949, except 2 dr. sed. (right) .....	6.62
1253465—1949, 2 dr. sed. (right)	4.70
1253462—1949, 3 pass. cpe. (right) .....	4.82
1343109—1950 to 52, except 2 dr. sed. (right) .....	3.95
1343386—1950, 2 dr. sed. (right)	....
1345859—1951-52, 2 dr. sed. (right) .....	4.85
1300686—1951-52, sub. (right)	2.10
1436442—1953 .....	4.45

**6 PLATE STRIKER LUGGAGE LID**

849065—1946 to 48 .....	.32
1299663—1949 to 52 .....	.42
1490321—1953 .....	.42

**7 WEATHERSTRIP LUGGAGE LID**

944358—1946 to 48, 4 dr., 2 dr. ....	3.32
905050—1946 to 48, club cpe. ...	3.57
974598—1946 to 48, conv. cpe., 3 pass. cpe. ....	2.21
1245704—1949 to 51, 4 dr. club cpe., conv. cpe. ....	4.99
1303459—1951-52, 2 dr. sedan. ...	4.99
1245715—1951-52, 3 pass. cpe. ...	5.36
1432662—1953, all .....	5.85

**8 SPRING AND GUIDE DECK LID HINGE**

896913—1946 to 48, 2 dr. sed. ...	2.26
130338—1946 to 49, 3 pass. cpe.	2.79
992062—1946 to 48, conv. cpe. ...	2.89
1233180—1946 to 48, 4 dr., 2 dr.	1.94
1303383—1949 to 52, 4 dr. club cpe. ....	2.79
1303542—1949 to 52, conv. cpe.	4.36
1431166—1951-52, 2 dr. sed. ...	2.26
1302382—1951-52, 3 pass. cpe.	2.79
1431905—1951-52, special club cpe. ....	2.79

**9 HINGE LUGGAGE LID**

893223—1946 to 48, 4 dr., 2 dr. ...	1.42
901963—1946 to 48, club cpe. ...	1.27
905339—1946 to 52, 3 pass. cpe.	1.37
974428—1946 to 48, conv. cpe. ...	1.57
1249746—1949-50, 2 dr. sed. ...	1.84
1303188—1949, conv. cpe. (right) .....	4.99
1241466—1949 to 52, 4 dr. 2 dr.	2.05
1305133—1950 to 52, 4 dr. club cpe. ....	2.05
1341566—1950 to 52, conv. cpe.	5.36
1381464—1951-52, 2 dr. sed. (right) .....	5.52
1457232—1953 (right*) .....	5.36
1458058—1953, conv. (right*) ..	5.43

**10 HANDLE LUGGAGE LID**

973557—1946 to 48 .....	1.90
1244887—1949, 2 dr. sed. ....	2.13
1244755—1949, except 2 dr. sed.	2.08
1478494—1950, except 2 dr. sed.	5.25
1347797—1950 to 52, 2 dr. sed. ...	4.41
1478494—1950 to 52, except 2 dr. sed. ....	5.25
1477746—1953 .....	3.95

**11 TAIL AND STOP LIGHT LENS**

1148877—1946 to 48 .....	.80
1244752—1949, except sub. ....	.83
1257454—1949, sub. ....	.80
1345853—1950, 2 dr. sed. (right) .....	1.60
1340146—1950 to 52, except 2 dr.	1.12
1300685—1950 to 52, sub. ....	1.62
1345853—1951-52, 2 dr. sed. (right) .....	1.60
1436451—1953 .....	1.85

**12 LICENSE LAMP BODY**

938987—1946 to 48 .....	5.46
1253386—1949 .....	14.50
1343310—1950-51, 2 dr. sed. ...	13.25
1343280—1950-51, except 2 dr. sed. ....	13.25
1340212—1951, sub. ....	1.37
1473311—1952, 2 dr. sed., P-22	11.45
1473320—1952, 3 pass. cpe., P-22	11.45
1383210—1953, housing .....	1.15

**13 NAME PLATE LUGGAGE LID**

1148894—1946 to 48, 4 dr. sed., 2 dr. sed. ....	6.85
1148895—1946 to 48, cpe. & conv. cpe. ....	6.85
1303502—1949, 2 dr. sed. ....	4.85
1246986—1947, except 2 dr. sed.	4.85
1338836—1950-51 .....	2.17
1473317—1952 .....	2.24
1496746—1953, overdrive .....	1.15
1477998—1953, Plymouth .....	1.15

**14 LUGGAGE COMPARTMENT LID**

1152689—1946 to 48, 4 dr., 2 dr. sed. ....	34.80
1152693—1946 to 48, 3 pass. cpe. ....	34.95
1152697—1946 to 48, club cpe. ...	34.95
1152896—1946 to 48, conv. cpe. ...	34.95

*continued*

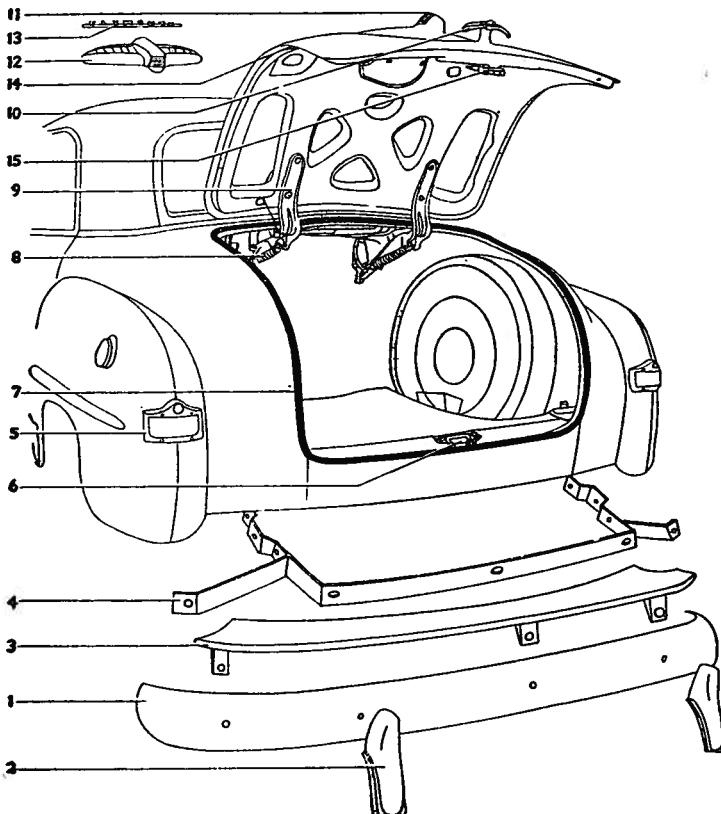

**Fig. 14—Rear Luggage Compartment & Rear Bumper**

*\* Opposite side one part number higher*



**PLYMOUTH 1946 thru 1953 BODY PARTS**

**Models P15, 17, 18, 19, 20, 22, 23 and 24. ALL BODY STYLES**

**Rear Luggage Compartment and Rear Bumper—  
continued**

1431094—1953 .....	39.25
1245058—1949, 4 dr. club cpe..	39.21
1245369—1949, 3 pass. cpe. ...	41.42
1248529—1949, 2 dr. sed. ....	37.00
1303177—1949, conv. cpe. ....	39.21
1477816—1949, except 2 dr. & 3 pass. cpe. ....	39.21
1338767—1950-51, 2 dr. sed. ..	37.00
1338772—1950-51, 3 pass. cpe..	41.42
1477816—1950-51, except 2 dr. & 3 pass. cpe. ....	39.21
1477819—1952, 2 dr. sed. ....	37.00
1477822—1952, 3 pass. cpe. ...	41.42
1477816—1952, except 2 dr. sed. & 3 pass. cpe. ....	39.21
<b>15 LOCK LUGGAGE LID</b>	
872924—1946 to 48 .....	1.70
1243506—1949 .....	1.85
1338762—1950-51 .....	1.70
1477553—1952 .....	1.99
1953 .....	....

**Frame Assembly**

See Fig. 15

<b>1 FRAME ASSEMBLY</b>	
956113—1946 to 48, exc. conv. cpe. ....	127.75
958049—1946 to 48, conv. cpe..	133.52
1323112—1949-50, 3 pass. cpe. & 2 dr. ....	127.75
1323113—1949-50, fordor & club cpe. ....	127.75
1323122—1949-50, conv. cpe. ..	172.75
1311496—1949, station wagon..	108.59
1323147—1949-50, sub. ....	110.31
1320343—1950, stn. wgn. ....	108.59
1323112—1951-52, exc. sub. P22	127.75
1323147—1951-52, sub. ....	110.31
1323113—1951-52, fordor-club cpe. P23 and special club cpe.	127.75
1227392—1951-52, conv. cpe. ...	....
1330460—1953, exc. conv., sub.	127.75
1403163—1953, conv. ....	207.25
1403104—1953, sub. ....	110.31

<b>2 FRONT CROSS MEMBER</b>	
1141119—1946 to 48 .....	30.17
1141209—1949 to 52 .....	30.17
1328250—1953 .....	30.17
<b>3 SUPPORT</b>	
1141216—1946 to 48 (right) ..	3.04
1312042—1949 to 52 .....	2.89
1328249—1953 .....	2.05
<b>4 BRACKET NO. 1</b>	
864372—1946 to 48 .....	.68
1312306—1949 to 52 .....	3.16
1402012—1953 .....	2.34
<b>5 BRACKET NO. 2</b>	
952948—1946 to 48, exc. conv. cpe. ....	2.10
954735—1946 to 48, conv. cpe..	2.79
1139440—1949 to 52, conv. cpe..	2.79
1137165—1950 to 52, exc. conv. cpe. ....	1.52
1402009—1953 .....	1.15
<b>6 BRACKET NO. 3</b>	
952917—1946 to 48 (right*) ..	.89
1139443—1949 to 52 .....	2.63
1402002—1953 .....	1.15
<b>7 BRACKET NO. 4</b>	
952914—1946 to 48, exc. conv. cpe. ....	2.16
1137182—1949 to 52 .....	2.16
1402002—1953 .....	1.15
<b>8 HANGER—REAR SPRING FRONT</b>	
1124575—1946 to 1948 (right*)	1.52
1124575—1949 to 52 (right*)..	1.52
1485125—1953 .....	.60
<b>9 BRACKET NO. 5</b>	
865599—1946 to 1948, exc. conv. cpe. ....	.52
867712—1946 to 1948, conv. cpe.	.89
1137174—1949 to 52, exc. conv. cpe. (right*) .....	1.32
1141374—1949 to 52, conv. cpe.	2.52
<b>10 HANGER—REAR SPRING REAR</b>	
862898—1946 to 48 (right*) ..	1.37
1137076—1949 to 52 (right*)..	1.37
1403207—1953 .....	1.37

<b>11 REAR CROSS MEMBER</b>	
862705—1946 to 48 .....	4.52
1140339—1949 to 52, exc. sub...	4.52
1141753—1949 to 52, sub. ....	4.52
1311497—1949-50, stn. wgn. ..	4.52
1405712—1953 .....	4.52
<b>12 INTERMEDIATE CROSSMEMBER</b>	
856481—1946 to 48 .....	12.77
1141736—1949 to 52 .....	6.42
1401995—1953, exc. sub. ....	6.42
1403141—1953, sub. ....	7.45
<b>13 ENGINE REAR SUPPORT</b>	
952347—1946 to 48 .....	5.63
1137054—1949 to 52 .....	5.63
1330461—1953 .....	9.00
<b>14 BRACE FRONT MEMBER</b>	
1137071—1949 to 53 .....	.75

**Front Suspension Parts**

See Fig. 16

<b>1 SEAL</b>	
867152—1946 to 53 .....	.10
<b>2 BAR</b>	
867150—1946 to 53 .....	2.50
<b>3 UPPER CONTROL ARM</b>	
862669—1946 to 50 .....	7.58
1322175—1951 to 53 .....	7.58
<b>4 UPPER CONTROL ARM BUSHING</b>	
1141150—1946 to 53 .....	.47
<b>5 FRONT SHOCK ABSORBER STUD, UPPER</b>	
861213—1946 to 50 .....	.71
1319783—1951 to 53 .....	.71
<b>6 SHOCK ABSORBER BUSHING</b>	
668164—1946 to 1950 .....	.15
1319555—1953, inner .....	.04
1319554—1953, outer .....	.04
<b>7 SHOCK ABSORBER BUSHING WASHER</b>	
1319555—1951-52, inner .....	.04
1319554—1951-52, outer .....	.04
1319902—1953, F & R. ....	.20
<b>8 SHOCK ABSORBER</b>	
1326163—1946 to 50 .....	5.88
1326164—1951-52, late 51 ....	5.88
1326164—1952-53, std. ....	5.88
1450041—1951-53, H.D. ....	12.14
<b>9 UPPER PIN KIT</b>	
1241500—1946 to 53, pin kit..	1.05
<b>10 UPPER BUMPER</b>	
861212—1946 to 50 .....	.83
1322128—1951 to 52 .....	.17
1402027—1953 .....	.22
<b>11 SEAL PIN BUSHING, UPPER</b>	
1117380—1946-50 .....	.10
1322912—1951 to 53 .....	.10

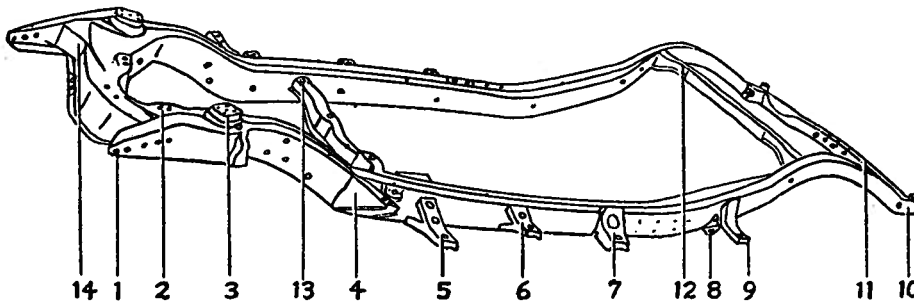

Fig. 15—Frame Assembly

\* Opposite side one part number higher

# BODY PARTS 1946 thru 1953 PLYMOUTH

Models P15, 17, 18, 19, 20, 22, 23 and 24. ALL BODY STYLES

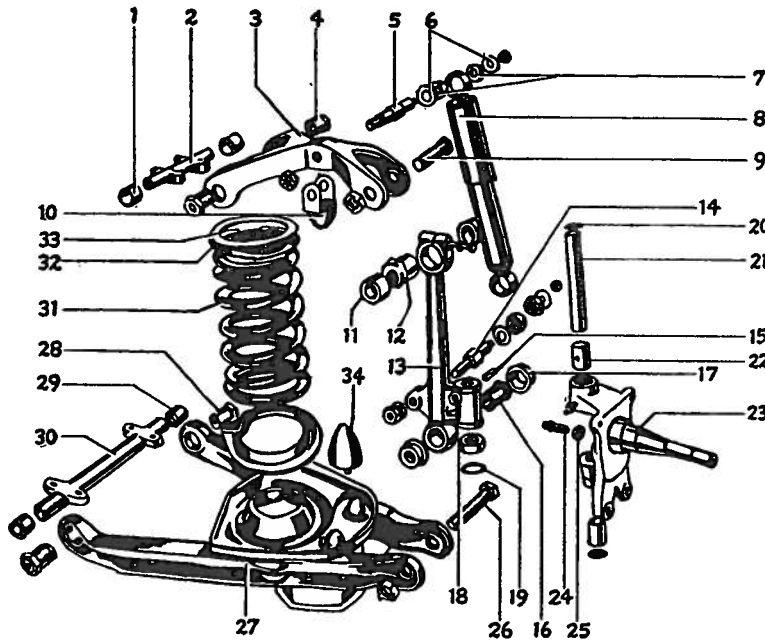

Fig. 16—Front Suspension

26 LOWER PIN & NUT PKG. 1241500—1946 to 53 .....	1.05
27 LOWER CONTROL ARM 1318178—1946 to 48 (right).. 1318179—1949 (right)..... 1318178—1950 to 53 (right)..	6.51 6.51 6.51
28 LOWER BAR BUSHING INNER 1318246—1951 to 53 .....	.69
29 PIVOT BAR DUST SEAL 696092—1946 to 53 .....	.10
30 PIVOT BAR, LOWER 852346—1946 to 53 .....	3.24
31 FRONT SPRINGS 1123244—1946 to 52, exc. conv. cpe. .... 1123245—1946 to 52, conv. cpe. 864845—1953, exc. conv. .... 864846—1953, conv. ....	7.85 7.85 7.85 7.85
32 FRONT SPRING SPACERS 657770—1946 to 52 .....	.55
1404216—1953 .....	1.35
33 FRONT SPRING SILENCER 691144—1946 to 53, upper.... 1137550—1946 to 52, lower....	.35 .39
34 LOWER CONTROL ARM BUMPER 1124470—1946 to 48..... 1137965—1949 .....	.83 .83
1319807—1950-51, P-22..... 1322966—1951-52, P-23..... 1404083—1953 .....	.83 .80 .55

PIN BUSHING, UPPER 1321130—1946-50 .....	1.13
1321130—1953, pkg. ....	1.13
KNUCKLE SUPPORT 856164—1946 to 50.....	7.89
1322165—1953 .....	7.82
SHOCK ABSORBER STUD, LOWER 1404148—1946 to 49, stud....	.75
1313952—1950 .....	.71
114497—Nut .....	.06
1404146—1953 .....	.75
KING PIN LOCK PIN 620371—1946 to 1953 .....	.11
LOWER ARM BUSHING PKG. 1064677—1946 to 1953 .....	.97
LOWER ARM BUSHING SEAL 1118883—1946 to 53 .....	.10
KING PIN THRUST BEARING 626503—1946 to 53 .....	.90
KING PIN THRUST BEARING SHIM 626871—1946 to 53 .....	.05
KING PIN OIL SEAL PLUG 103894—1946 to 53 .....	.05
KING PIN 626975—1946 to 53.....	.82
KING PIN BUSHING 633672—1946 to 53 .....	.26
KING PIN KIT 933435—1946 to 53 .....	4.42

23 STEERING KNUCKLE 859088—1946 to 48.....	10.09
1311432—1949 to 53 .....	10.09
24 SET SCREW 603342—1948 to 53 .....	.10
25 SET SCREW NUT 120371—1948 to 53 .....	.05

## STEERING GEOMETRY

1946 to 1953

CASTER: 1946 to 1950 0 to 1 degree positive.

1951 to 1953 1 degree negative to 1 degree positive.

CAMBER: 1946 to 1950 0 to 3/4 degree positive.

1951 to 1953 3/8 degree negative to 3/8 degree positive. Left side to be 1/4 degree to 1/2 degree higher than right side, within these limits.

TOE-IN: 0 to 1/16 inch.

TOE-OUT TURNS (TURNING RADIUS):  
Outer Wheel 20 degrees. Inner Wheel 22 degrees. 1953, 18 3/4 degrees.

KING PIN INCLINATION: 1946 to 1950 4 3/4 to 6 degrees.

1951 to 1953 5 to 6 1/2 degrees.

## ADJUSTMENTS

CASTER: Factory says not adjustable.

CAMBER: Is controlled by turning eccentric upper support bushing until correct adjustment is secured.

\* Opposite side one part number higher

# PLYMOUTH FRAMES

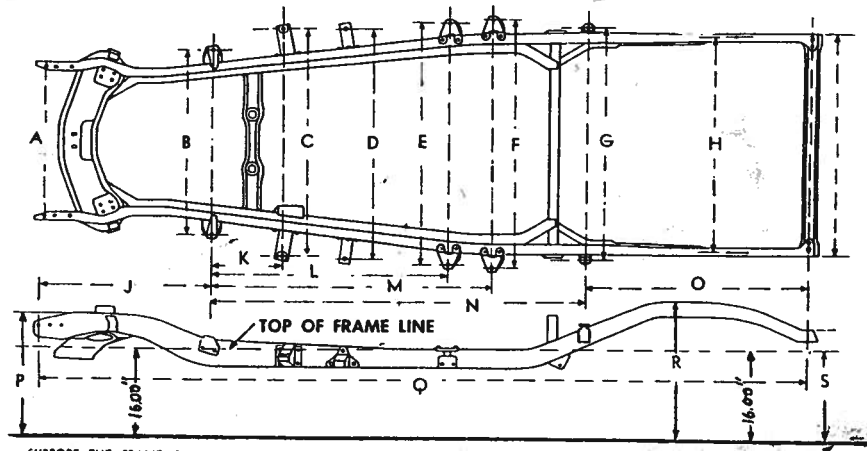

SUPPORT THE FRAME ON JACKS TO LOCATE THE TOP OF THE SIDE RAILS EXACTLY 16 INCHES FROM A LEVEL WORK SURFACE

Model and Series	Dimension Point																		
	A	B	C	D	E	F	G	H	I	J	K	L	M	N	O	P	Q	R	S
1946-1948 All Models.....	34	40 <sup>1</sup> / <sub>32</sub>	50 <sup>3</sup> / <sub>4</sub>	52 <sup>3</sup> / <sub>8</sub>	52 <sup>3</sup> / <sub>8</sub>	52 <sup>3</sup> / <sub>8</sub>	50 <sup>1</sup> / <sub>2</sub>	46 <sup>3</sup> / <sub>4</sub>	48 <sup>1</sup> / <sub>4</sub>	37 <sup>7</sup> / <sub>32</sub>	15 <sup>29</sup> / <sub>32</sub>	50 <sup>1</sup> / <sub>32</sub>	59 <sup>1</sup> / <sub>32</sub>	79 <sup>29</sup> / <sub>32</sub>	48 <sup>7</sup> / <sub>8</sub>	23 <sup>7</sup> / <sub>16</sub>	166	26 <sup>13</sup> / <sub>16</sub>	20 <sup>7</sup> / <sub>8</sub>

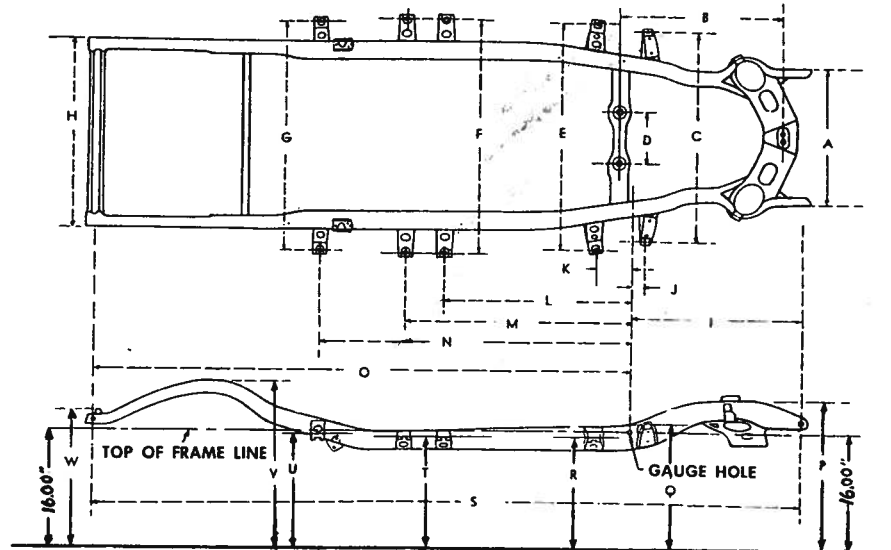

SUPPORT THE FRAME ON JACKS TO LOCATE THE TOP OF THE SIDE RAILS EXACTLY 16 INCHES FROM A LEVEL WORK SURFACE

Model and Series	Dimension Point																						
	A	B	C	D	E	F	G	H	I	J	K	L	M	N	O	P	Q	R	S	T	U	V	W
1949-52 4 Door Sedan	31 <sup>3</sup> / <sub>4</sub>	40 <sup>33</sup> / <sub>64</sub>	49 <sup>3</sup> / <sub>4</sub>	117 <sup>7</sup> / <sub>8</sub>	52 <sup>13</sup> / <sub>16</sub>	54 <sup>7</sup> / <sub>16</sub>	53 <sup>1</sup> / <sub>2</sub>	43 <sup>1</sup> / <sub>2</sub>	43	25 <sup>7</sup> / <sub>64</sub>	9 <sup>1</sup> / <sub>2</sub>	45 <sup>1</sup> / <sub>2</sub>		74 <sup>21</sup> / <sub>32</sub>	126 <sup>1</sup> / <sub>8</sub>	23 <sup>7</sup> / <sub>8</sub>	18 <sup>1</sup> / <sub>16</sub>	15 <sup>9</sup> / <sub>16</sub>	169 <sup>1</sup> / <sub>8</sub>	15 <sup>9</sup> / <sub>16</sub>	15 <sup>13</sup> / <sub>16</sub>	28 <sup>3</sup> / <sub>32</sub>	21 <sup>9</sup> / <sub>32</sub>
1949-52 Club Coupe	31 <sup>3</sup> / <sub>4</sub>	40 <sup>33</sup> / <sub>64</sub>	49 <sup>3</sup> / <sub>4</sub>	117 <sup>7</sup> / <sub>8</sub>	52 <sup>13</sup> / <sub>16</sub>	54 <sup>7</sup> / <sub>16</sub>	53 <sup>1</sup> / <sub>2</sub>	43 <sup>1</sup> / <sub>2</sub>	43	25 <sup>7</sup> / <sub>64</sub>	9 <sup>1</sup> / <sub>2</sub>		54 <sup>7</sup> / <sub>8</sub>	74 <sup>21</sup> / <sub>32</sub>	126 <sup>1</sup> / <sub>8</sub>	23 <sup>7</sup> / <sub>8</sub>	18 <sup>1</sup> / <sub>16</sub>	15 <sup>9</sup> / <sub>16</sub>	169 <sup>1</sup> / <sub>8</sub>	15 <sup>9</sup> / <sub>16</sub>	15 <sup>13</sup> / <sub>16</sub>	28 <sup>3</sup> / <sub>32</sub>	21 <sup>9</sup> / <sub>32</sub>
1953 All Closed Models	31 <sup>3</sup> / <sub>4</sub>		48	117 <sup>7</sup> / <sub>8</sub>	51 <sup>1</sup> / <sub>8</sub>	53 <sup>13</sup> / <sub>16</sub>		48 <sup>3</sup> / <sub>4</sub>	5		5 <sup>3</sup> / <sub>4</sub>	47 <sup>3</sup> / <sub>4</sub>					14 <sup>13</sup> / <sub>32</sub>	14 <sup>19</sup> / <sub>32</sub>		14 <sup>25</sup> / <sub>32</sub>	14 <sup>25</sup> / <sub>32</sub>	29 <sup>3</sup> / <sub>16</sub>	20 <sup>7</sup> / <sub>16</sub>

# FRAMES PLYMOUTH

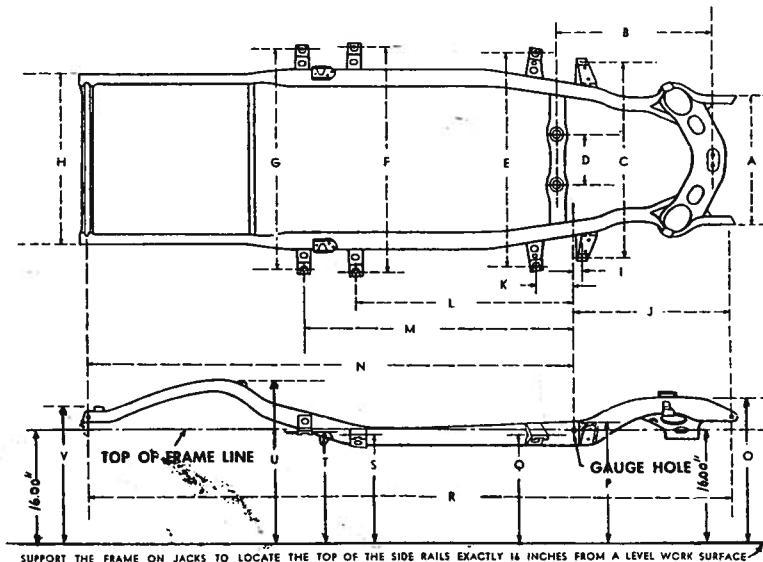

Model and Series	Dimension Point																					
	A	B	C	D	E	F	G	H	I	J	K	L	M	N	O	P	Q	R	S	T	U	V
1949-52 3 p. Cpe. and 2 dr. Sed.	31 <sup>3</sup> / <sub>4</sub>	40 <sup>33</sup> / <sub>64</sub>	49 <sup>3</sup> / <sub>4</sub>	11 <sup>7</sup> / <sub>8</sub>	52 <sup>13</sup> / <sub>16</sub>	54 <sup>7</sup> / <sub>16</sub>	53 <sup>7</sup> / <sub>2</sub>	43 <sup>1</sup> / <sub>2</sub>	25 <sup>7</sup> / <sub>64</sub>	43	9 <sup>1</sup> / <sub>2</sub>	54 <sup>5</sup> / <sub>8</sub>	67 <sup>5</sup> / <sub>32</sub>	118 <sup>5</sup> / <sub>8</sub>	23 <sup>7</sup> / <sub>8</sub>	18 <sup>1</sup> / <sub>16</sub>	15 <sup>9</sup> / <sub>16</sub>	16 <sup>15</sup> / <sub>8</sub>	15 <sup>9</sup> / <sub>16</sub>	15 <sup>13</sup> / <sub>16</sub>	28 <sup>3</sup> / <sub>32</sub>	21 <sup>9</sup> / <sub>32</sub>

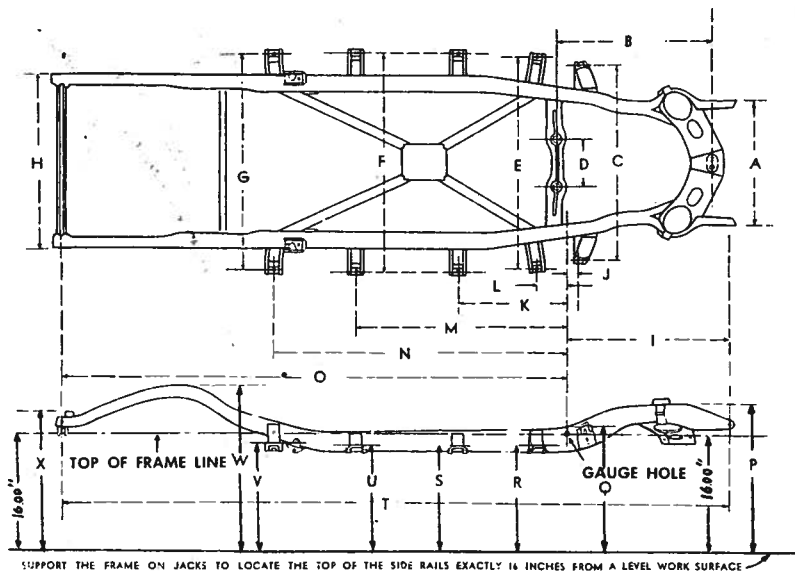

Model and Series	Dimension Point																							
	A	B	C	D	E	F	G	H	I	J	K	L	M	N	O	P	Q	R	S	T	U	V	W	X
1949-52 Conv. Club Coupe	31 <sup>3</sup> / <sub>4</sub>	40 <sup>33</sup> / <sub>64</sub>	49 <sup>3</sup> / <sub>4</sub>	11 <sup>7</sup> / <sub>8</sub>	52 <sup>13</sup> / <sub>16</sub>	54 <sup>7</sup> / <sub>16</sub>	53 <sup>7</sup> / <sub>2</sub>	43 <sup>1</sup> / <sub>2</sub>	43	27 <sup>8</sup> / <sub>8</sub>	29 <sup>1</sup> / <sub>4</sub>	9 <sup>1</sup> / <sub>2</sub>	54 <sup>5</sup> / <sub>8</sub>	74 <sup>21</sup> / <sub>32</sub>	126 <sup>1</sup> / <sub>8</sub>	23 <sup>7</sup> / <sub>8</sub>	18 <sup>9</sup> / <sub>64</sub>	13 <sup>3</sup> / <sub>16</sub>	13 <sup>7</sup> / <sub>32</sub>	169 <sup>1</sup> / <sub>8</sub>	13 <sup>7</sup> / <sub>32</sub>	14 <sup>1</sup> / <sub>4</sub>	28 <sup>3</sup> / <sub>32</sub>	21 <sup>9</sup> / <sub>32</sub>
1953 Conv. Club Coupe	31 <sup>13</sup> / <sub>16</sub>		48 <sup>1</sup> / <sub>16</sub>	11 <sup>7</sup> / <sub>8</sub>	51 <sup>3</sup> / <sub>16</sub>	53 <sup>7</sup> / <sub>8</sub>		48 <sup>13</sup> / <sub>16</sub>	33 <sup>1</sup> / <sub>4</sub>	5	31 <sup>7</sup> / <sub>8</sub>	5 <sup>3</sup> / <sub>4</sub>	47 <sup>3</sup> / <sub>4</sub>	68 <sup>1</sup> / <sub>16</sub>			17 <sup>9</sup> / <sub>16</sub>	14 <sup>9</sup> / <sub>16</sub>	14 <sup>3</sup> / <sub>4</sub>	171 <sup>35</sup> / <sub>64</sub>	14 <sup>3</sup> / <sub>4</sub>	14 <sup>3</sup> / <sub>4</sub>	29 <sup>3</sup> / <sub>16</sub>	20 <sup>7</sup> / <sub>16</sub>