

FORD 1949 thru 1951 BODY PARTS

Models 98BA, 98HA, 0BA, 0HA, 1BA and 1HA. ALL BODY STYLES

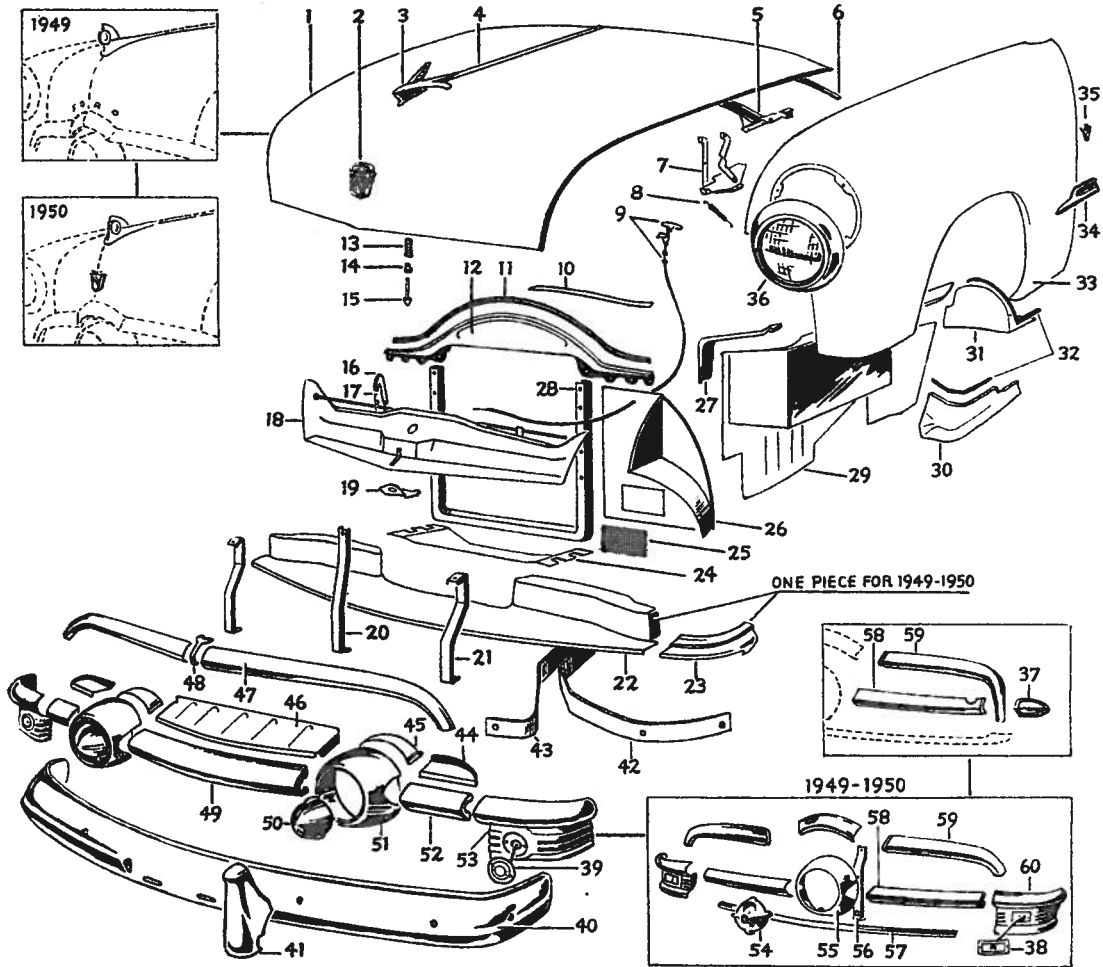

Fig. 1

Front of Car

See Fig. 1

1 HOOD ASSY.	
0A-16611-A—1949-1950	27.93
1A-16611—1951	27.93
2 HOOD FRONT LETTER	
8A-16606-A—1949 "F"33
8A-16606-B—1949 "O"45
8A-16606-C—1949 "R"45
8A-16606-D—1949 "D"33
2 HOOD FRONT EMBLEM	
0A-16607—1950 early
0A-16637-B—1950 late, to 1951	1.16
0A-16644—frame 1950-5152
3 HOOD TOP ORNAMENT	
0A-16850—1950 & 49	4.83
8A-16850—1949
1A-16851—1951, base metal ...	4.93
0A-16852—1951, upper45
1A-16852—1951, upper, plastic	.43

4 HOOD TOP CENTER MLDG.	
8A-16736—1949 to 195086
1A-16736—195184
5 HOOD REAR REINFMT.	
8A-16668-A—1949	3.39
0A-16668—1950
1A-16668—1951	3.39
6 COWL HOOD PAD	
8A-16740—1949 to 195133
7 HOOD LINK, BRKT., & HINGE ASSY.	
8A-16796-B—1949 (right)	2.41
0A-16796—1950 to 1951 (right)	2.45
8 HOOD HOLD DOWN SPRING	
8A-16789-B—194912
0A-16789—1950 to 195112
9 HOOD CONTROL CABLE	
8A-16916-B—1949, ex. sta. wag.
8A-16916-C—1950 to 1951, ex.
sta. wag.	1.47
8L-16916—1949, sta. wag.	1.55
0A-16916—1950 to 1951, sta.
wag.

10 RADIATOR CENTER AIR DEFLECTOR SEALER	
8BA-8349—1949 to 1951
11 RADIATOR CENTER AIR DEFLECTOR SEALER	
8BA-8344-B—1949 to 1950. 8 cyl. "B"	1
8HA-8344-B—1949 to 1950. 6 cyl. "H"	1
1BA-8344—1951. 8 cyl. "B" ...	1
1HA-8344—1951. 6 cyl. "H" ...	1
12 RADIATOR CENTER AIR DEFLECTOR	
8BA-8327—1949 to 1950. 8 cyl. "B"	1
8HA-8327—1949 to 1950. 6 cyl. "H"	1
1BA-8327—1951. 8 cyl. "B" ...	1
1HA-8327—1951. 6 cyl. "H" ...	1
13 HOOD LOCK SPRING	
11A-16925—1949 to 1951

* Opposite side one part number higher

BODY PARTS 1949 thru 1951 FORD**Models 98BA, 98HA, 0BA, 0HA, 1BA and 1HA. ALL BODY STYLES**

14 HOOD LOCK SPRING GUIDE 11A-16927—1949 to 195117	0HA-16058—1950 to 1951 (right)	4.98	41 FRONT BUMPER GUARD 8A-17996-A—1949 (right)	4.02
15 HOOD LOCK DOWEL 11A-16929—1949 to 195114	30 CLUTCH PEDAL SHIELD 8A-16173-B—1949 to 1950	1.05	0A-17996—1950 (right)	4.02
16 HOOD AUXILIARY CATCH HOOK 8A-16896-B—1949 to 195024	31 FENDER APRON TO COWL PANEL 0A-16032—1949 to 1951	1.67	1A-17996—1951 (right)	3.98
1A-16896—195124	32 COWL PANEL TO FENDER FILLER ANTI-SQUEAK 8M-16070-A—1949 to 195141	42 FRONT BUMPER OUTER ARM 8A-17754-A—1949 (right)	1.98
17 HOOD SUPPORT ROD 8A-16826—1949 to 195069	33 FRONT FENDER (RIGHT) 8A-16005-B—1949 to 1950	22.72	0A-17754—1950 (right)	1.84
0A-16826—195169	0A-16005-D—1951	27.24	1A-17754—1951 (right)	1.84
18 GRILLE HOOD LOCKING PANEL ASSY. 0A-8162-D—1949 to 1950	5.43	34 FRONT FENDER MLDG. 8A-16188-A—1949 exc. Station Wagon (right)	1.19	43 FRONT BUMPER INNER ARM 8A-17766-A—1949 (right)	1.59
1A-8162—1951	5.47	8A-16188-B—1949 Station Wagon (right)	1.52	0A-17766—1950 (right)	1.48
19 HOOD LOCK DOWEL GUIDE PLATE 7A-8331—1949 to 1951	0A-16188-A—1950 exc. Station Wagon & Crestliner (right)	1.19	1A-17766—1951 (right)	1.48
20 RADIATOR GRILLE SUPPORT 0A-8162-D—1949 to 1950	5.47	0A-16188-B—1950 Station Wagon (right)	1.19	44 RADIATOR GRILLE UPPER BAR 1A-8380—1951 (right)55
21 GRILLE SUPPORT BRACKET 8A-8232-A—194971	1A-16188-B—1951 Custom (right)	1.17	46 RADIATOR GRILLE UPPER CENTER BAR 1A-8363—1951	1.59
8A-8232-B—195088	1A-16188-C—1951 Deluxe (right)	1.19	47 RADIATOR GRILLE OPENING PANEL 1A-8190—1951 (right)	5.00
1A-8232—195155	1A-16188-E—1951 Victoria (right)	1.02	48 GRILLE OPENING PANEL JOINT COVER 1A-8221—1951 (right)66
22 FRONT BUMPER STONE DEFLECTOR 0BA-17744-B—1949 to early 1950, 8 cyl.	8.91	35 FRONT FENDER SIDE EMBLEM 1BA-16237—1951 8 cylinder79	49 GRILLE CENTER CONNECTING BAR 1A-8241—1951	4.76
0BA-17744—1950 late. 8 cyl.	8.91	36 HEADLAMP ASSY 8C-13002-B—1949	6.14	50 GRILLE RING ORNAMENT 8BA-8216-B—1949 to 1950 8 cyl.	4.05
0HA-17744-A—1949. 6 cyl.	8.91	0A-13002-B—1950	6.14	8HA-8216-B—1949 to 1950 6 cyl.	4.05
0HA-17744-B—1950 early. 6 cyl.	8.91	1A-13002—1951	6.14	1A-8216—1951	1.97
0HA-17744—1950 late. 6 cyl.	8.91	HEADLAMP DOOR 0A-13045-C—1949 to 1950	2.15	51 GRILLE RING ORNAMENT MEDALLION 8BA-8218—1949 to 1950 8 cyl. (Use 8BA-8216-B)
1BA-17744—1951. 8 cyl.	9.09	1A-13045-C—1951	2.59	8HA-8218—1949 to 1950 6 cyl.41
1HA-17744—1951. 6 cyl.	9.09	HEADLAMP SEALED BEAM UNIT 09A-13007—1949 to 1951	1.43	1A-8217—1951 (right)	8.69
23 SEE ITEM NO. 22		HEADLAMP BULB RETAINING RING 0A-13018-C—1949 to 1951	1.33	52 GRILLE CENTER BAR ASSY. 8A-8150-B—1949 (right)	6.50
24 ENGINE FRONT SPLASH SHIELD 8A-16550-B—1949 to 1950	1.97	37 PARKING LAMP ASSY. 8A-13200—1949 (right)	3.90	0A-8150-B—1950 (right)	5.60
1A-16550—1951	1.84	PARKING LAMP LENS 8A-13208—1949 (right)29	1A-8150—1951 (right)	5.38
25 FRONT VENT AIR CONDUCTOR 8A-8716—1949 to 1950 (right)17	0A-13208—195032	53 GRILLE EXTEN. PANEL 1A-8224—1951	5.93
1A-7001908—1951 (right)	1A-13208—195129	54 SEE ITEM NO. 50	
26 RADIATOR SIDE AIR DEFLECTOR 1A-8104—1951 (right)	1.90	PARKING LAMP DOOR 8A-13236—1949 (right)	1.40	55 GRILLE ORNAMENT RING 8A-8217-B—1949	8.47
0A-8104—1950 (right)	2.05	0A-13236—1950	1.22	8A-8217-C—1950	6.50
0A-8104-A—A—1949 (right)	2.05	1A-13210—195188	56 SEE ITEM NO. 21	
27 FRONT FENDER TO RAD. SUPT. REINFM.T. 8A-16142—1949 to 1951 (right)55	38 PARKING LAMP BODY 0A-13215—1950 (right)28	57 FRONT BUMPER DEFLECTOR MLDG. 8A-17819—1949	2.36
28 RAD. & FRONT FENDER APRON SUPT. 8A-16139—1949 to 1950	1.88	1A-13206—1951	0A-17819—1950	2.19
1A-16139—1951	2.59	39 SEE ITEM NO. 38		58 SEE ITEM NO. 52	
29 FRONT FENDER APRON 8BA-16054-A—1949. 8 cyl. (right)	10.29	40 FRONT BUMPER IMPACT BAR 8A-17757-B—1949	24.28	59 GRILLE UPPER FRAME 8A-8242-A—1949 (right)	5.00
0BA-16054-B—1950. 8 cyl. (right)	10.14	0A-17757—1950	23.17	0A-8242-B—1950 (right)	5.00
0BA-16054—1951. 8 cyl. (right)	10.14	1A-17757—1951	23.17	60 GRILLE EXTEN. PANEL 0A-8224-B—1950 (right)	6.22
8HA-16054-A—1949. 6 cyl. (right)	10.29				
0HA-16043-B—1950 to 1951 (right)	4.78				

* Opposite side one part number higher

FORD 1949 thru 1951 BODY PARTS

Models 98BA, 98HA, 0BA, 0HA, 1BA and 1HA. ALL BODY STYLES

Instrument Panel

See Fig. 2

1 INSTRUMENT PANEL ASSY.	
8A-7004320-HP—1949, exc. 79	14.95
8A-7904320-B—1949, 79	16.87
0A-7004320-AP—1950, exc. 79	15.46
0A-7904320-AP—1950, 79	16.46
1A-7004320-BP—1951, exc. 79
1A-7004320-DP—1951, exc. 79	14.95
1A-7904320-AR—1951, 79	17.88
BA-7004320-CP—1952
2 INSTRUMENT FINISH PANEL	
1A-7004338-AP—1951	2.47
3 INSTRUMENT PANEL MLDG.	
0A-7004332—1950, 70C (right)	1.35
1A-7004332-AA—1951, 70A, 72C, 73A (right)	1.84
1A-7004332-BZ—1951, 60, 70B, C, 72B, 73B, 76 (right)	2.49
1A-7904332—1951, 79 (right)	1.21
BA-7004332-A—1952, exc. 79 (right)	.36
BA-7904332-A—1952, 79 (right)	.66
4 HEATER CONTROL OPENING COVER CLIP	
1A-7004491—1951	.10
5 HEATER CONTROL OPENING COVER	
1A-7004489-CB—1951	.42
6 STEERING COLUMN FINISH PLATE	
1A-7004467-AB—1951, std. trans.	.43
1A-7004467-BB—1951, Fordomatic	.43
7 CIGAR LIGHTER SOCKET TUBE.	
8A-7004620-BZ6—1949 to 1952	1.38
8 CIGAR LIGHTER ELEMENT AND KNOB ASSY.	
8A-7004610-A—1949 chrome	1.48
0A-7004610-A—1950 ivory	1.48
0A-7004610-BZ6—1950 to 1951 70C, 79 black	1.21
0A-7004610-C—1951, 70C dark brown	1.48
1C-8104610-A—1952	1.32

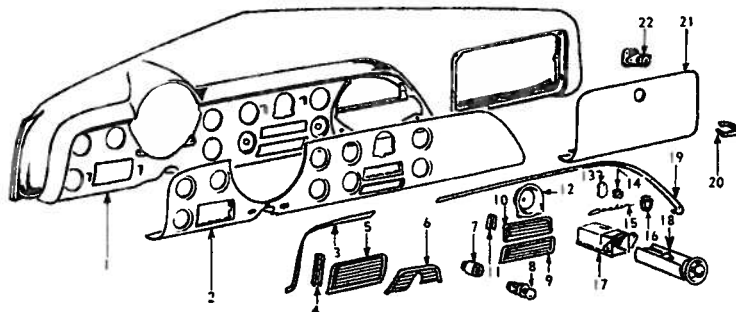

Fig. 2—Instrument Panel

9 RADIO PUSH BUTTON OPENING COVER	
1A-7004360-CB—1951 w/o radio	.49
10 RADIO OPENING COVER	
8A-7904370-A3—1949, 79	.52
0A-7004370-AP—1949 to 1950, exc. 79	.55
8A-7904370-AF—1950, 79	.52
1A-7004370-CB—1951, exc. 79	.49
1A-7904370-AS—1951, 79	1.89
11 RADIO OPENING COVER CLIP	
1A-7004416—1951	.10
12 CLOCK OPENING MEDALLION	
0A-7004428-AP—1949 to 1950	.45
1A-7004428—1951	.46
13 MEDALLION MTG. PLATE	
1A-7004564—1951	.09
14 INSTRUMENT PANEL MEDALLION	
1A-7004539—1951	.64
15 RADIO GRILLE NAME PLATE	
0A-7004460—1950, 70C	1.30
1A-6004460-A—1951, 60	.51
1A-7004460-A—1951 chrome	.64
1A-7004460-C—1951 painted
1A-7004460-B—1951, 70C	.64
16 MEDALLION RETAINER	
1A-7004540-A—1951	.45
17 ASH RECEPTACLE RETAINER	
1A-7004826—1951	.57
18 ASH RECEPTACLE	
1A-7004810-A—1951 early	1.21
1A-7004810-B—1951	1.21
19 SEE ITEM #3	
20 GLOVE COMPT. DOOR STOP	
8A-7006117-AP—1950, all; 1951, 79 prime	.38
1A-7006117-AP—1951, exc. 79 prime	.34
21 GLOVE COMPT. DOOR (INC. HINGE)	
8A-7006024-AP—1949, exc. 79 prime	2.94
8A-7006024-AF—1949, 79 maple	3.06
1A-7006024-AP—1951 prime	3.27

22 GLOVE COMPT. DOOR LOCK ASSY.	
8A-7006081-B—1949, 2 keys	1.
8A-7006081-E—1950, 2 keys	1.
1A-7006081-C—1951, 2 keys	1.

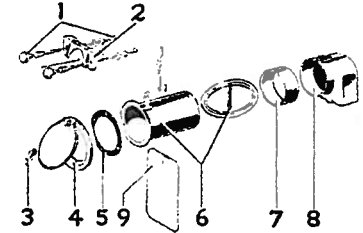

Fig. 3

Ventilating System

See Fig. 3

1 AIR CONTROL ASSY.	
8A-7001890-C—1949 (right)	1.
8A-7001890-D—1949 (right) custom	1.
0A-7001890-A—1950, 70a, 72c, 73a (right)
0A-7001890-B—1950, 70b, 2, 3, 76, 9 (right)
0A-7001890-D—1950, 70c (right)
1A-7001890-A—1951, 60, 70, 2, 3, 6 (right)
0A-7001890-D—1951, 79 (right)
FAA-7001890-A—1952, 59, 60, 70, 2, 3, 6, 8, 9 (right)	2.
2 VENT. AIR CONTROL BRACKET	
8A-7001938-AP—1949, prime
8A-7901938—1949, 79, grey
0A-7001938-AP—1950, prime
1A-3678—1951, exc. sta. wag.
0A-7901938—1950 to 1951, sta. wag.
3 REGISTER DOOR HANDLE	
8A-7001844—1949
8M-7301844-A—1952
BA-7001844-A—1952, heater door
4 REGISTER ASSY.	
8A-7001814-B—1949, 70, 2, 3, 6, 9	1.
0A-7001814—1950 to 1951	1.
BA-7001814-B—1952 (right)	1.
5 VENT. AIR VALVE GASKET	
8A-7001880—1949 to 1951
BA-7001880-A—1952
6 VENT. AIR VALVE ASSY.	
8A-7001850-A—1949 (right)	2.
0A-7001850-A—1950 to 1951 (right)	1.
BA-7001850-A—1952, not used with heater	3
7 VENT. AIR DUCT CONNECTOR	
8A-7001878—1949 to 1951
BA-7001878-B—1952
8 VENT. AIR DUCT ASSY.	
8A-7001902-B—1949 to 1951	1.
BA-7001902-B—1952	8

* Opposite side one part number higher

BODY PARTS 1949 thru 1951 FORD

Models 98BA, 98HA, 0BA, 0HA, 1BA and 1HA. ALL BODY STYLES

Sheet Metal & Fuel Tank

—Fordor

Body Styles—73A, 73B

See Fig. 4

1 ROOF PANEL & SILENCER ASSY.	
1A-7050026-A—1949 to 1951, 70,73	64.59
1A-7250026—1949 to 1951, 72 ..	72.49
0A-7950026—1949 to 1951, 79..	108.88
2 SEE BODY MLDG. SECTION ITEM NO. 12	
3 ROOF SIDE RAIL REAR REINFMT.	
8A-7851200-B—1949 to 1951 73 (right)78
4 ROOF REAR SIDE RAIL	
8A-7351214-A—1949, 73	1.26
8A-7351214-B—1950 to 1951, 73	1.86
5 LUGGAGE COMPT. DOOR	
0A-7040112-B—1949, 70, 2, 3,6, w/lock	38.35
0A-7040112-B—1949 to 1950, less lock & hinges	38.35
1A-7040110—1951, less lock & hinges	39.88
6 QUARTER PANEL EXTENSION	
0A-7027934—1949 to 1951, 70, 2, 3, 6 (right)	3.00
7 QUARTER PANEL TO EXTEN. MLDG. UPPER	
0A-7029052—1949 to 1951, 70 73, (right)72
0A-7229052—1949 to 1951, 72 (right)81
1A-7629052-A—1951, 60, 76 (right)82
8 QUARTER PANEL TO EXTEN. LOWER MLDG.	
8A-7029080-B—1949 to 1950, 70, 2, 3, 624
9 REAR QUARTER & SIDE PANEL	
8A-7327840-D—1949, 73 (right)	47.85
0A-7327840—1950, 73 (right)	43.19
1A-7327840-J—1951, 73 (right)	46.03
10 REAR DOOR ASSY. LESS PAINT TRIM & REGLTR.	
8A-7324622—1949, 73 (right) .	49.97
0A-7324622—1950, 73 (right).	49.97
1A-7324622—1951, 73 (right) .	49.97
11 CENTER BODY PILLAR	
8A-7324300-B	8.16
0A-7324300	8.47
12 FRONT DOOR ASSY.	
8A-7320122-A—1949, 73 (right)	49.97
0A-7320122-B—1950, 73 (right)
1A-7320122—1951, 73 (right).	49.97
13 ROOF SIDE RAIL REINFMT.	
8A-7051196-A—1949, 73 (right)
8A-7051196-B—1950 to 1951 (right)48

14 WDSHD. REINFMT. TO PILLAR GUSSET	
8A-7003586—1949 to 1950 (right)45
1A-7003586—1951 (right)31
15 ROOF SIDE RAIL	
8A-7051184-A—1949 (right) ..	3.30
0A-7051184—1950 to 1951 (right)	3.16
16 COWL SIDE PANEL & PILLAR ASSY.	
8A-7002154—1949 (right)	9.15
0A-7002154—1950 (right)	9.15
1A-7002154—1951 (right)	9.15
17 DASH PANEL ASSY.	
0A-7001610-A—1949 to 1950..	9.94
18 DASH TO FRAME SUPT. & BRACE	
8A-7001790-B—1949 to 1950 (right)	1.96
1A-7001790—1951 (right)	1.96
19 FLOOR FRONT TRANS. COVER PLATE	
8A-7012115-A—1949	1.78
20 FRONT FLOOR PAN ASSY.	
8A-7011135-D—1949 to 1950 ..	17.74
1A-7011135-B—1951	16.51
21 FLOOR REAR PAN ASSY.	
8A-7011215-B—1949
8A-7011215-C—1950
1A-7011215—1951	23.18
22 SPARE WHEEL MTG. BRACKET	
8A-7047070—1949 to 195076
1A-7047070—195173
23 LUGGAGE COMPT. OPENING TO FLOOR GUSSET	
8A-7044830-B—1949 to 1951 (right)16
24 LOWER BACK PANEL	
8A-7040824—1949 to 1951	2.40
25 REAR QUARTER WHEELHOUSE PANEL	
8A-7027882—1949 to 1951 (right)	7.11
26 BODY SIDE LOWER EDGE REAR REINFMT.	
8A-7020032—1949 to 1951	1.00
27 BODY SIDE LOWER EDGE FRONT REINFMT.	
8A-7020030—1949 to 1951	1.50
28 BODY ROCKER PANEL	
8A-7310130-C—1949 to 1951 ..	3.27

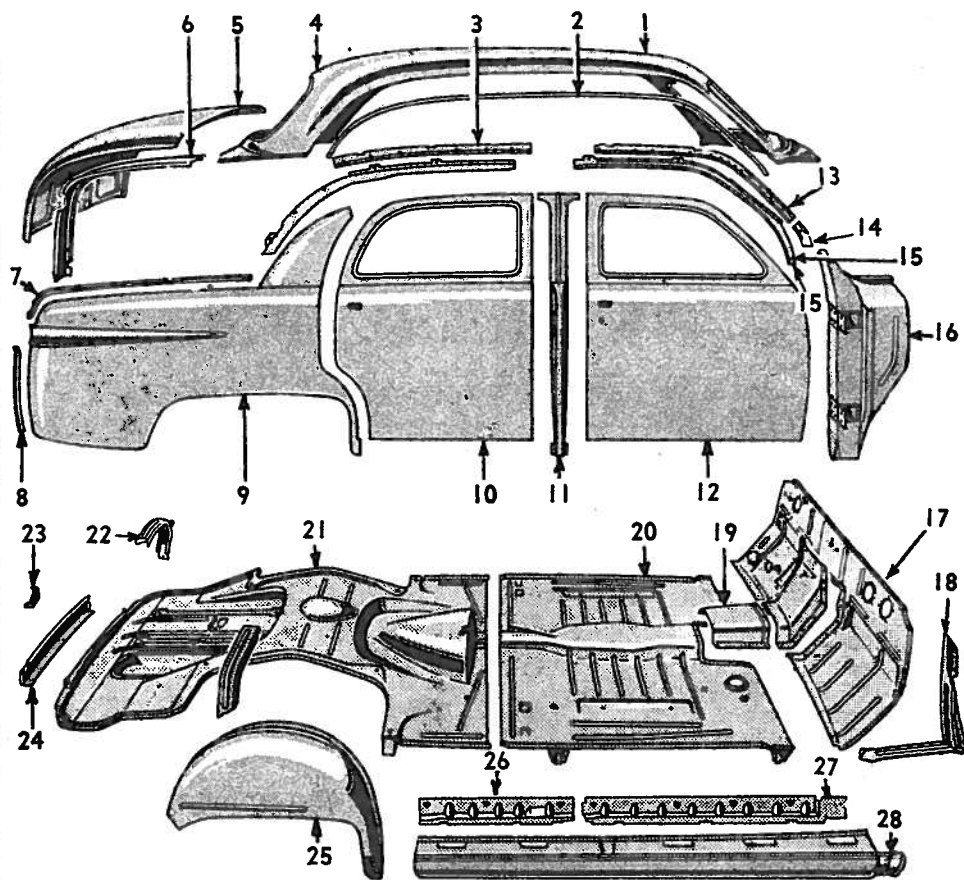

Fig. 4—Body Sheet Metal—Fordor

* Opposite side one part number higher

FORD 1949 thru 1951 BODY PARTS

Models 98BA, 98HA, 0BA, 0HA, 1BA and 1HA. ALL BODY STYLES

Body Moldings, Wheels and Trim

Body Types—73A, B

See Fig. 5

1 HOOD FRONT EMBLEM LETTER		
0A-16637—1950 emblem	1.16	
0A-16644—1950 frame52	
8A-16606-A—1949 letter "F" ..	.33	
8A-16606-B—1949 letter "O" ..	.45	
8A-16606-C—1949 letter "R" ..	.45	
8A-16606-D—1949 letter "D" ..	.33	
2 HOOD TOP ORNAMENT		
0A-16850—1950	4.83	
8A-16850—1949	
1A-16851—1951	4.93	
3 HOOD TOP CENTER MLDG.		
8A-16736—1949 to 195086	
1A-16736—195184	
4 HEADLAMP ASSY. (LESS BULB)		
8C-13002-B—1949	6.14	
0A-13002-B—1950	6.14	
1A-13002—1951	6.14	
SEALED BEAM BULB		
09A-13007—1949 to 1951	1.43	
SEALED BEAM RETAINING RING		
0A-13018-C—1949 to 1951 ...	1.33	
5 HEADLAMP DOOR		
0A-13045-C—1949 to 1950	2.15	
1A-13045-B—1951	2.59	
6 WDSHD. OUTER CENTER WTHSTP. RETAINER		
8A-7003078-A—1949 to 1951 exc. 79 painted	1.83	
8A-7003078-B—1949 to 1950, 70B, 2, 3, steel	1.83	
0A-7003078—1950 to 1951, 70B, C, 72B, 73B steel	1.83	
8A-7903078—1949 to 1950, 79 ..	1.60	
0A-7903078—1950 to 1951, 79 ..	1.48	
7 WDSHD. GLASS		
8A-7603100—1951, 60, 76	12.76	
8A-7003100—1949 to 1951, 70, 2, 3	12.92	
8A-7903100—1949 to 1951, 79 ..	12.76	
8 WASHD. OUTER FINISH MLDG. (Steel)		
8A-7003088-B—1949 to 1950, 70B, 2B, 3B (right)	2.19	
0A-7003088—1950 to 1951, 70B, C, 72B, 3B (right)	2.53	
8A-7603088-B—1949 to 1950, 76 (right)	1.89	
0A-7603088—1950 to 1951, 76, 60, double grooved	1.68	
8A-7903088—1949 to 1950, 79 (right)	1.84	
9 WDSHD. WTHSTP. ASSY.		
8A-7003110-D—1949 to 1951, 70A, 2, 3, 72C	5.53	
8A-7003100-E—1949 to 1950, 70B, 2, 3, single groove	5.76	

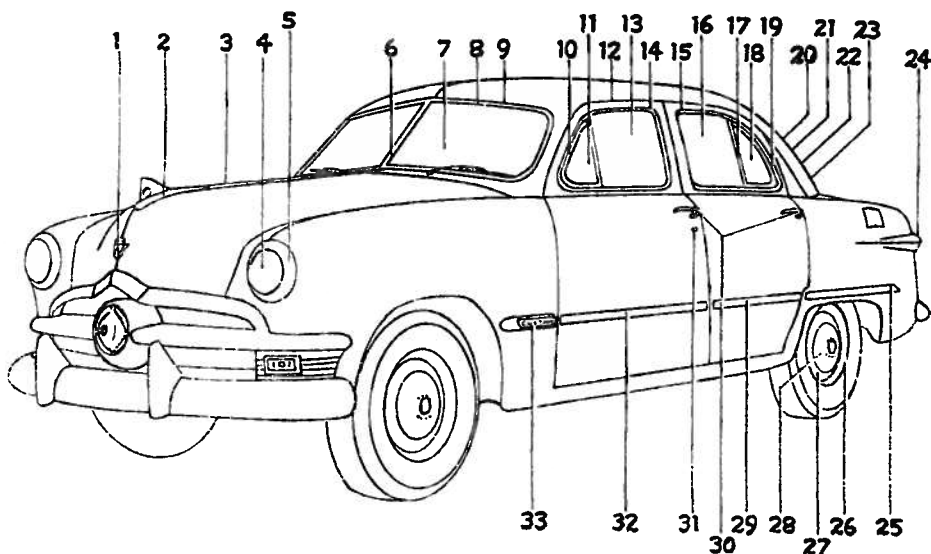

Fig. 5—Body Moldings, Wheels and Trim—Fordor

0A-7003110—1950 to 1951, 70B, C, 72B, 3, double groove	4.97	8A-7621410-A—1949 to 1951, 60, 76	6.8
8A-7603110-B—1949 to 1950, 76, single groove	5.85	8M-7921410-A—1949 to 1951, 79	9.84
0A-7603110—1950 to 1951, 60, 76, double groove	5.58	14 WINDOW REVEAL MLDG. & WTHSTP.	
8A-7903110-A—1949 to 1950, 79, single groove, (right) ..	5.34	8A-7020984-B—1949, 72 (right)	3.34
10 FRONT DOOR VENT. WINDOW ASSY.		0A-7020984-A—1950 to 1951, 70, 2 (right)	3.04
8A-7021406-A—1949, 70, 2, 3 (right)	6.54	8A-7320984-B—1949, 73 (right)	2.84
8A-7621406-A—1949, 76 (right)	9.61	0A-7320984-A—1950 to 1951, 73 (right)	2.84
8A-7621406-C—1951, 60, 76 (right)	9.61	15 REAR DOOR REVEAL MLDG. & WTHSTP.	
8A-7021406-C—1950 to 1951, 70, 2, 3, (right)	6.54	8A-7325588-B—1949, 73 (right)
8M-7921406—1950 to 1951, 79 (right)	10.36	0A-7325588-A—1950 to 1951, 73 (right)	2.44
11 FRONT DOOR VENT. GLASS		16 REAR DOOR GLASS	
8A-7021412-A, B—1949, 70, 2, 3	2.74	8A-7325712-A—1949 to 1951, 73	5.24
8A-7621412-A—1949, 76	3.21	17 REAR DOOR VENT. DIV. BAR	
8M-7921412-A—1949 to 1951, 79	2.20	8A-7326902-A—1949, 73	
8A-7021412-B—1950 to 1951, 70, 2, 3	2.74	8A-7326902-B—1950 early, 73B (right)	3.74
8A-7621412-B—1950 to 1951, 60, 76	3.21	0A-7326902—1950 late to 1951 (right)	3.64
12 ROOF DRIP MLDG.			3.64
8A-7051700—1949 to 1951, 70, 3 (right)88	18 REAR DOOR VENT. GLASS	
8A-7251700—1949 to 1951, 72 (right)	1.54	8A-7326870-A—1949 to 1951 ..	2.70
1A-6051700—1951, 60 (right) ..	.93	0A-7326870-A—1950 to 1951, stationary	2.74
13 FRONT DOOR WINDOW GLASS		19 REAR DOOR VENT. GLASS & FRAME ASSY.	
8A-7021410-A—1949 to 1951, 70, 2	7.32	8A-7326876-A—1949, 73, 73B (right)	6.81
8A-7321410-A—1949 to 1951, 73	5.23	0A-7326876—1950 to 1951, 73A (right)	6.81

* Opposite side one part number higher

BODY PARTS 1949 thru 1951 FORD

Models 98BA, 98HA, 0BA, 0HA, 1BA and 1HA. ALL BODY STYLES

20 BACK WINDOW GLASS	
8A-7042006—1949 to 1951, 70, 2, 3	16.84
8M-7942006-A—1949 to 1951, 79	7.99
1A-6042006-B—1951, 60	16.88
21 BACK WINDOW GLASS WTHSTP.	
8A-7042084-E—1949 to 1951, exc. 60	3.78
8A-7042084-D—1949 to 1950, 70B, 2, 3	3.78
0A-7042084-B—1950 to 1951, 70B, 2, 3, 70C	3.76
1A-6042084-A—1951, 60	8.86
22 BACK WINDOW OUTER MLDG.	
0A-7042430—1949 to 1951	2.19
23 BACK WINDOW OUTER MLDG. JOINT COVER	
8A-7042432-B—1949 to early 195005
8A-7042432-C—1950 late to 195107
1A-6042432—1951, 60.....	.09
24 REAR LAMP ASSY. INCL. BULB	
8A-13402-A—1949 to 1951, sta. wag.	4.29
8A-13404-A—1949 to 1950, exc. sta. wag.	4.40
1A-13404—1951, exc. sta. wag.	7.22
25 REAR QUARTER PANEL OUTER MLDG.	
8A-7029038-B—1949 to 1950, ex. 70C (right)	2.05
0A-7029038—1950, 70C (right)	1.71
8A-7329038-B—1949 to 1950, 73 (right)	1.67
REAR QUARTER PANEL OUTER MLDG.	
1A-7029038-B—1951, exc. 73B	2.07
1A-7329038-B—1951, 73B	1.71
26 WHEEL (W/600x16 tire)	
8A-1015-C—1949 to 1951, exc. sta. wag.	7.72
8A-1015-D—1949 to 1951, sta. wag. (7.10x15 tire)	7.72
27 WHEEL TRIM RING	
8A-18303-A—1949 to 1951, 16 in. dia. set of 5	11.85
8A-18303-B—1949 to 1951, 15 in. dia. set of 5	11.65
28 HUB CAP	
8A-1130-B—1949, 1950.....	2.93
0A-1130—1950 Crestliner.....	7.12
1A-1130-A—1951	2.93
29 REAR DOOR OUTER MLDG.	
8A-7325556—1949 to 1950, 73 (right)	1.74
1A-7325556—1951, 73B (right)	1.62
30 DOOR OUTER HANDLE	
8A-7022400-A—1949, 70, 2, 3..	2.67
8A-7622400-A—1949, 76	1.71
0A-7022400-A—1950 to 1951, 70, 2, 3	2.16
0A-7622400-A—1950 to 1951, 76, 60	2.14

31 DOOR PILLAR LOCK & SLEEVE ASSY.	
0A-7021984-B—1949 to 1950 (right)	1.88
1A-7021984—1951 (right).....	1.93
32 FRONT DOOR OUTER MLDG.	
8A-7020938—1949 to 1950, 70A, B, 72, 6 (right).....	2.28
0A-7020938—1950 to 1951, 70C, upper (right)	2.14
8A-7320938—1949 to 1950, 73 (right)	1.67
1A-7020938—1951, exc. 73B (right)	2.19
1A-7320938—1951, 73B (right)	1.67
33 SEE FRONT OF CAR SECTION ITEM NO. 34	

Front Doors

Body Types—70, 72, 73

See Fig. 6

DOOR ASSY.	
8A-7020122-A—1949, 70, 72 (right)	55.92
8A-7320122-A—1949, 73 (right)	49.97
1A-7020122—1950-51, 70, 72 (right)	55.92
1A-7320122—1950-51, 73 (right)	49.97
1 FRONT DOOR GLASS WTHSTP. (Inner)	
8A-7021452-A—1949, 70, 72 (right)96
8A-7321452-A—1949, 73 (right)	1.02
0A-7021452—1950 to 1951, 70, 72 (right)85
0A-7321452—1950 to 1951, 73 (right)69

2 FRONT DOOR WINDOW GLASS	
8A-7021410-A—1949 to 1951, 70, 2	7.32
8A-7321410-A—1949 to 1951, 73	5.23
3 FRONT DOOR GLASS CHAN. & RETAINER	
8A-7021458-A—1949, 70, 2 (right)76
8A-7021458-B—1950 to 1951, 70, 284
8A-7321458-A—1949, 7395
8A-7321458-B—1950 to 1951, 73	.60
4 FRONT DOOR GLASS LOCK SIDE GLASS RUN	
8A-7021550—1949 to 1951, 70, 2, 351
5 FRONT DOOR LOCK SIDE GLASS RETAINER	
0A-7021572-A—1949 to 1951, 70, 2, 3 (right)40
6 DOOR LOCK ASSY.	
8A-7021812-B—1949, 70, 2, 3 (right)	4.55
0A-7021812—1950 to 1951, 70, 2, 3 (right)	3.86
7 LOCK REMOTE CONTROL & LINK	
8A-7021818-B—1949, 70, 2 (right)	1.45
8A-7321818-B—1949, 73 (right)	1.17
0A-7021818—1950, 70, 2 (right)	.95
0A-7321818—1950, 73 (right)..	1.05
1A-7021818—1951, 70, 2 (right)	.79
1A-7321818—1951, 73 (right)..	.90
8 FRONT DOOR FINISH STRIP	
8A-7020904-CP—1949 to 1951, 70, 2 (right) prime	4.35
8A-7320904-CP—1949 to 1951, 73 (right) prime	4.92

continued

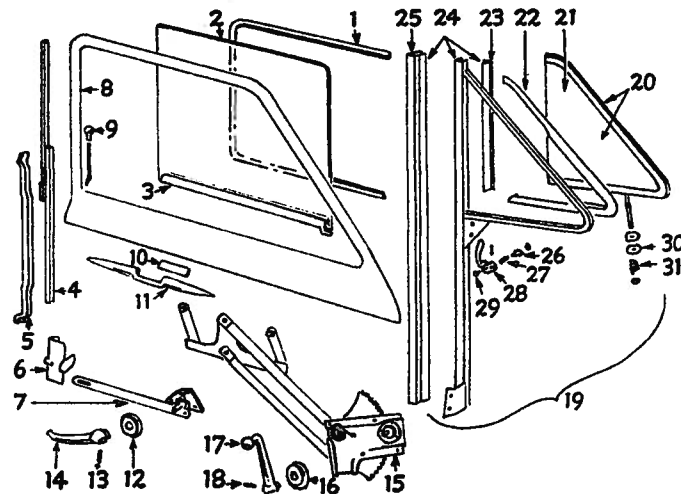

Fig. 6—Front Doors—Typical of Body Types 70, 72, 73

* Opposite side one part number higher

FORD 1949 thru 1951 BODY PARTS

Models 98BA, 98HA, 0BA, 0HA, 1BA and 1HA. ALL BODY STYLES

Front Doors—continued

9 LOCKING CONTROL ROD KNOB	
8A-7021850-A—1949, neutral grey28
8A-7021850-B—1949 to 1951, dark grey28
10 FINISH STRIP ORNAMENT	
8A-7020988-A—1949, 70b, 2, 3 (right)31
0A-7020988-A—1950, 70b, 2, 3 (right) grey86
0A-7020988-B—1950, 70b, 2, 3 (right) black88
11 FINISH STRIP ORNAMENT RETAINER	
8A-7020946—194964
12 DOOR & WINDOW REGLTR. ESCUTCHEON	
0A-7022618-E—1949 to 1950, 70a, 2, 3, chrome40
0A-7022618-F—1949 to 1950, 70b, 2, 3, chrome40
1A-7023370-B—195104
13 HANDLE RETAINING PIN	
8A-7023354-B—194903
0A-7023354—195008
14 INSIDE DOOR HANDLE	
8A-7022614-A—1949	1.09
8A-7022614-B—1950	1.14
1A-7022600—1951	1.14
15 DOOR WINDOW REGLTR.	
8A-7023200-A—1949, 70, 2 (right)	4.10
8A-7323200-A—1949, 73 (right)	4.10
8A-7023200-B—1950, 70, 2 (right)	4.10
8A-7323200-B—1950, 73 (right)	4.10
1A-7023200—1951, 70, 2 (right)	4.38
1A-7323200—1951, 73 (right) ..	4.10
16 SEE ITEM NO. 12	
17 DOOR WINDOW REGLTR. HANDLE	
8A-7023342-C—1949, 70B, 2, 3, chrome	1.59
8A-7023342-D—1949, 70A, 2, 3, light grey	1.59
0A-7023342-A—1950, 70A, 2, 3, ivory less insert	1.36
0A-7023342-B—1950, 70B, 2, 3, ivory with insert	1.41
1A-7023342—1951, 70, 2, 3	1.40
18 DOOR HANDLE RETAINING PIN	
8A-7023354-B—194903
0A-7023354—195008
19 DOOR VENT. WINDOW ASSY.	
8A-7021402-A—1949, 70, 2, 3 (right)	21.12
0A-7021402—1950-51, 70, 2, 3 (right)	21.23
20 FRONT DOOR VENT. WINDOW ASSY.	
8A-7021406-A—1949, 70, 2, 3 (right)	6.54
8A-7021406-C—1950-51 (right) ..	6.54

21 FRONT DOOR VENT. GLASS	
8A-7021412-B—1949 to 51	2.74
22 FRONT DOOR VENT. WTHSTP.	
8A-7021448-A—1949, 70, 2, 3 (right)	1.14
8A-7021448-B—1950-51, 70, 2, 3 (right)	1.45
23 DOOR VENT. DIV. BAR WTHSTP.	
8A-7021450-B—1949, 70, 2, 3 (right)28
8A-7021450-C—1950-51, 70, 2, 3 (right)24
24 FRONT DOOR VENT. RETAINER & DIV. BAR ASSY.	
8A-7022204-A—1949, 70, 2, 3 ..	3.22
8A-7022204-B—1950, 70, 2, 3
0A-7022204—1950-51	3.36
25 FRONT DOOR GLASS HINGE SIDE RUN	
8A-7021546-A—1949, 70, 2, 3, on div. bar52
8A-7021546-B—1950-51, 70, 2, 3, on div. bar52
26 DOOR VENT. HANDLE LOCKING KEY	
01A-7022920—194914
8A-7022920—1950-5114
27 DOOR VENT. HANDLE SPRING	
01A-7022986—1949 to 5102
28 DOOR VENT. HANDLE	
8A-7022916-A—1949, 70, 2, 3 ..	.57
8A-7022916-C—1950 to 51, 70, 2, 357
29 DOOR VENT. HANDLE BUTTON	
01A-7022984—194903
30 DOOR VENT. PIVOT STOP	
8A-7022992—1949 (right)06
8A-7022992—1950-5106
31 DOOR VENT. PIVOT SPRING	
01A-7022926—1949 to 5127

Rear Door

*Body Type—73 Fordor
See Fig. 7*

DOOR ASSY. (Hinges, less paint & trim)	
8A-7324622-B—1949 (right) ...	49.9
1A-7324622—1951 (right)	49.9
0A-7324622-B—1950 (right) ...	49.9
1 DOOR GLASS RUN HINGE SIDE RETAINER	
8A-7325758—1949 to 19512
2 DOOR GLASS HINGE SIDE RUN ASSY.	
8A-7325728—1949 to 19516
3 DOOR GLASS	
8A-7325712-A—1949 to 1951 ...	5.2
4 DOOR GLASS INNER WTHSTP.	
8A-7325854-A—1949 (right) ..	1.1
0A-7325854—1950-51 (right) ..	.6
5 DOOR VENT. RETAINER & DIV. BAR	
8A-7326902-A—1949 (right) ..	3.7
8A-7326902-B—1950 (right)
0A-7326902—1951 (right)	3.6
6 DOOR VENT. WTHSTP.	
8A-7326894-A—1949, 73 (right)	1.0
0A-7326894—1950-51, 73A, stationary (right)9
8A-7326894-B—1950-51, 73B (right)	1.0
7 DOOR VENT. GLASS & FRAME ASSY	
8A-7326876-A—1949 (right) ...	6.8
0A-7326876—1950-51, 73B (right)	6.8
8 DOOR VENT. GLASS	
8A-7326870-A—1949 to 1951 ..	2.7
0A-7326870-A—1950-51, 73A, stationary	2.7
9 DOOR VENT. HANDLE	
8A-7022916-A—1949 (right) ..	.5
8A-7022916-C—1950-51 (right)	.5

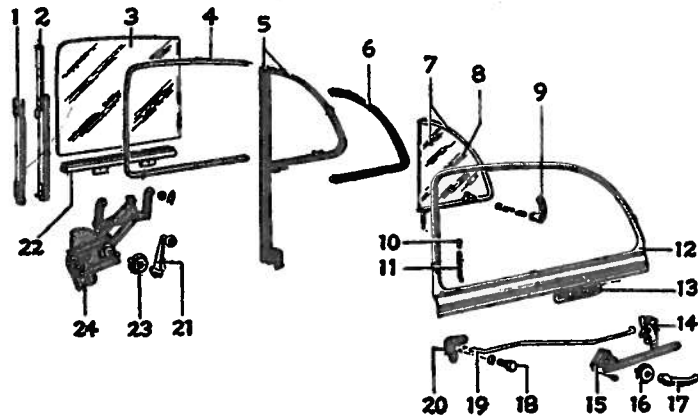

Fig. 7—Rear Door—Body Type 73 Fordor

* Opposite side one part number higher

BODY PARTS 1949 thru 1951 FORD

Models 98BA, 98HA, 0BA, 0HA, 1BA and 1HA. ALL BODY STYLES

10 LOCKING CONTROL ROD KNOB	
8A-7021850-A—1949, neutral grey28
8A-7021850-B—1949 to 1951, dark grey28
11 DOOR LOCK PUSH BUTTON ROD	
8A-7326460-A—1949 to 1951..	.03
12 DOOR FINISH STRIP (Prime)	
8A-7325514-EP—1949 to 1951 (right)	4.06
13 DOOR FINISH STRIP ORNAMENT	
8A-7020988-A—1949 (right)...	.31
0A-7020988-A—1950, grey (right)86
0A-7020988-B—1950, black (right)88
14 DOOR LOCK ASSY.	
8A-7021812-B—1949	4.55
0A-7021812—1950-51	3.86
15 LOCK REMOTE CONTROL & LINK ASSY.	
8A-7326404-B—1949 (right)...	.67
0A-7326404—1950 (right)....	.90
1A-7326404—1951 (right)90
16 REGULATOR & INNER DOOR HANDLE ESCUTCHEON	
0A-7022618-E—1949-50, 73A ..	.40
0A-7022618-F—1949-50, 73B ..	.40
1A-7023370-B—195104
17 DOOR INNER HANDLE	
8A-7022614-A—1949, square shaft	1.09
8A-7022614-B—1950, round shaft	1.14
1A-7022600—1951	1.14
18 DOOR LOCK BELLCRANK BOLT	
351716-S8—1949 to 1951.....	.06
19 DOOR LOCK LINK	
8A-7326420-A—1949 (right) ..	.16
0A-7326420-A—1950-51 (right)	.14
20 DOOR LOCK BELLCRANK	
8A-7326448—1949 to 1951....	.04
21 DOOR REGLTR. HANDLE	
8A-7023342-C—1949, chrome, 73B	1.59
8A-7023342-D—1949, light grey, 73A	1.59
0A-7023342-A—1950, 73A, ivory w/o insert	1.86
0A-7023342-B—1950, 73B, ivory w/o insert	1.41
1A-7023342—1951, 73	1.40
22 DOOR GLASS CHAN. & RETAINER ASSY.	
8A-7326228-B—1949 to 1951...	.49
23 SEE ITEM NO. 16	
24 REGULATOR ASSY.	
8A-7327000-A—1949, square shaft (right)	4.10

8A-7327000-B—1950, round shaft (right)	4.10
1A-7327000—1951, round shaft (right)	4.71

Quarter Window

Body Types—70A, B, C

See Fig. 8

1 WINDOW FINISH STRIP	
8A-7029002-CP—1949 to 1951, 70A	5.23
8A-7029002-DP—1949 to 1951, 70B	5.23
2 WINDOW GLASS	
8A-7029710-A—1949 to 1951 ..	6.31
3 WINDOW DIV. BAR & BRKT.	
8A-7030234-A—1949-50, 70A (right)	2.41
0A-7030234—1951, 70A (right)	2.41
VENT, WINDOW RETAINER & DIV. BAR	
8A-7030216-A—1949, 70B (right)	2.91
0A-7030216-A—1950, 70B, C, (right)	3.06
0A-7030216-D—1951, 70B, C (right)	3.21
4 VENT, WINDOW GLASS	
8A-7030210-A—1949 to 1951, 70A	3.25
8A-7030210-B—1949 to 1951, 70B, C	2.68
5 VENT, HANDLE	
8M-7022916—1950-51 (right)..	.69

6 WINDOW REAR WTHSTP.	
8A-7030248-A—1949 to 1951, 70A (right)	1.90
8A-7030248-C—1949 to 1951, 70B, C (right)	1.28
7 FRONT GLASS RUN	
8A-7030102—1949 to 195137
8 GLASS CHANNEL	
8A-7029900-A—1949 to 1951 (right)71
9 WINDOW REGULATOR	
8A-7030306-A—1949, square shaft (right)	4.10
8A-7030306-B—1950, round shaft (right)	4.10
1A-7030306—1951, round shaft (right)	4.12
10 REGULATOR HANDLE ESCUTCHEON	
0A-7022618-E—1949-50, 70A ..	.40
0A-7022618-F—1949-50, 70B, C	.40
1A-7023370-B—195104
11 REGULATOR HANDLE	
8A-7023342-C—1949, 70B chrome	1.59
8A-7023342-D—1949, 70A, grey	1.59
0A-7023342-A—1950, 70A, ivory less insert	1.36
0A-7023342-B—1950, 70B, ivory w/insert	1.41
0A-7023342-D—1950, 70C, dark brown	1.15
1A-7023342—1951	1.40
12 WINDOW GLASS INNER WTHSTP	
8A-7029744-A—1949 (right) ..	.75
0A-7029744—1950-51 (right) ..	.69

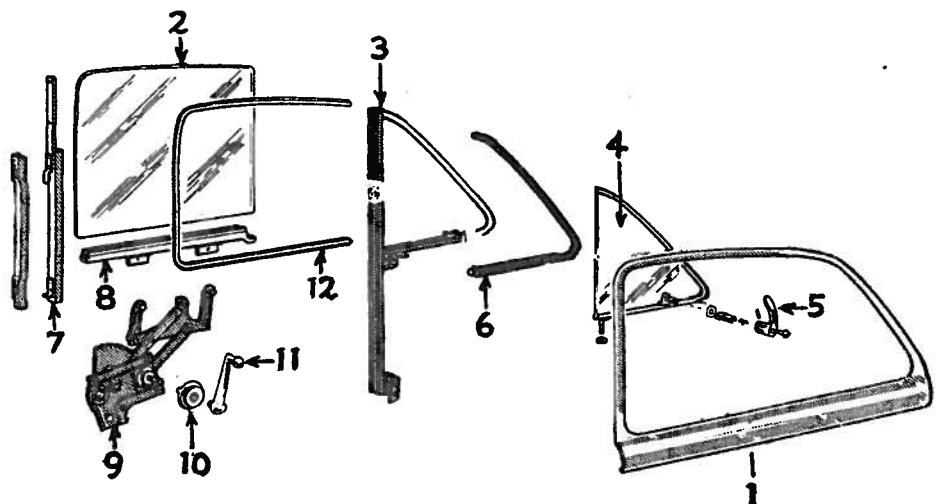

Fig. 8—Quarter Window—Body Type 70

* Opposite side one part number higher

FORD 1949 thru 1951 BODY PARTS

Models 98BA, 98HA, 0BA, 0HA, 1BA and 1HA. ALL BODY STYLES

Quarter Window

Body Types 72A, B, C

See Fig. 9

GLASS & FRAME ASSY.	
8A-7229700-B—1949, 72B (right)	16.01
1 WINDOW FINISH STRIP (Prime)	
8A-7229002-DP—1949, 72A, C (right)	3.22
8A-7229002-EP—1949-50, 72B (right)	5.16
8A-7229002-DP—1950-51, 72C (right)	3.22
2 WINDOW GLASS	
8A-7229710-B—1949, 72A, C... ..	6.33
8A-7229710-C—1949 to 1951, 72B	5.74
8A-7229710-C—1950-51, 72C ..	5.74
3 WINDOW GLASS & FRAME ASSY.	
8A-7230506-B—1949-50, 72B (right)	11.12
0A-7230506-B—1951, 72B (right)	11.39
4 GLASS FRAME HANDLE	
78-735280—1949-50, 72B (right)39
5 WINDOW WTHSTP.	
8A-7229904-A—1949 to 1951, 72A, C, stationary (right)..	2.07
0A-7229904-B—1949 to 1951 72B (right)	2.59

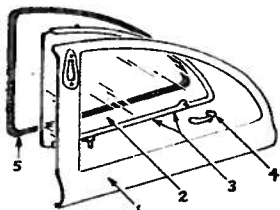

Fig. 9

Sheet Metal and Fuel Tank

Body Types 70A, B, 72A, B—

Tudor & Coupes

See Fig. 10

1 ROOF PANEL AND SILENCER ASSY.	
1A-7050026-A—1949-50, 70, 2; 1951, 70	64.59
1A-7250026—1951, 72	72.49
2 ROOF DRIP MLDG.	
8A-7051700—1949 to 1951, 70 (right)88
8A-7251700—1949 to 1951, 72 (right)	1.54
3 ROOF RAIL SIDE REINFMT.	
8A-7051196-A—1949, 70, 2 (right)
8A-7051196-B—1950, 70, 2 (right)48

4 WINDSHIELD REINFMT. TO PILLAR GUSSET	
8A-7003586—1949 to 1950 (right)45
1A-7003586—1951 (right)31
5 ROOF SIDE RAIL	
8A-7051184-A—1949 (right)... ..	3.30
0A-7051184—1950-51 (right).. ..	3.16
6 QUARTER & SIDE PANEL	
8A-7027840-E—1949, 70 (right) ..	47.88
8A-7227840-E—1949, 72 (right) ..	47.85
1A-7027840-L—1951, 70 (right) ..	46.01
0A-7027840—1950, 72 (right)
1A-7227840-J—1951, 72 (right) ..	46.03
0A-7227840—1950, 72 (right) ..	47.85
7 QUARTER PANEL EXTEN. UPPER MLDG.	
0A-7029052—1949 to 1951, 70 (right)72
0A-7229052—1949 to 1951, 72 (right)81
8 QUARTER PANEL EXTEN.	
0A-7027934—1949 to 1951.....	3.00
9 LUGGAGE COMPT. DOOR	
0A-7040112-B—1949-50	38.35
1A-7040110—1951	39.88

10 QUARTER PANEL EXTEN. MLDG.	
8A-7029080-B—1949-5024
11 DOOR ASSY.	
8A-7020122-A—1949 (right)... ..	55.92
0A-7020122-B—1950 (right)...
1A-7020122—1951 (right).....	55.92
12 COWL SIDE PANEL	
8A-7002154—1949 (right)	9.15
0A-7002154—1950 (right)	9.15
1A-7002154—1951 (right)	9.15
13 DASH PANEL ASSY.	
0A-7001610-A—1949-50	9.94
14 FLOOR TRANS. REAR COVER PLATE	
8A-7012120-A—1949	1.03
8A-7012120-B—1950	1.03
15 DASH TO FRAME SUPPORT & BRACE	
8A-7001790-B—1949-50 (right) ..	1.96
1A-7001790—1951 (right)	1.96
16 FRONT FLOOR PAN ASSY.	
8A-7011135-D—1949-50	17.74
1A-7011135-B—1951	16.51
17 REAR FLOOR PAN ASSY.	
8A-7011215-B—1949
8A-7011215C—1950
1A-7011215—1951	23.18

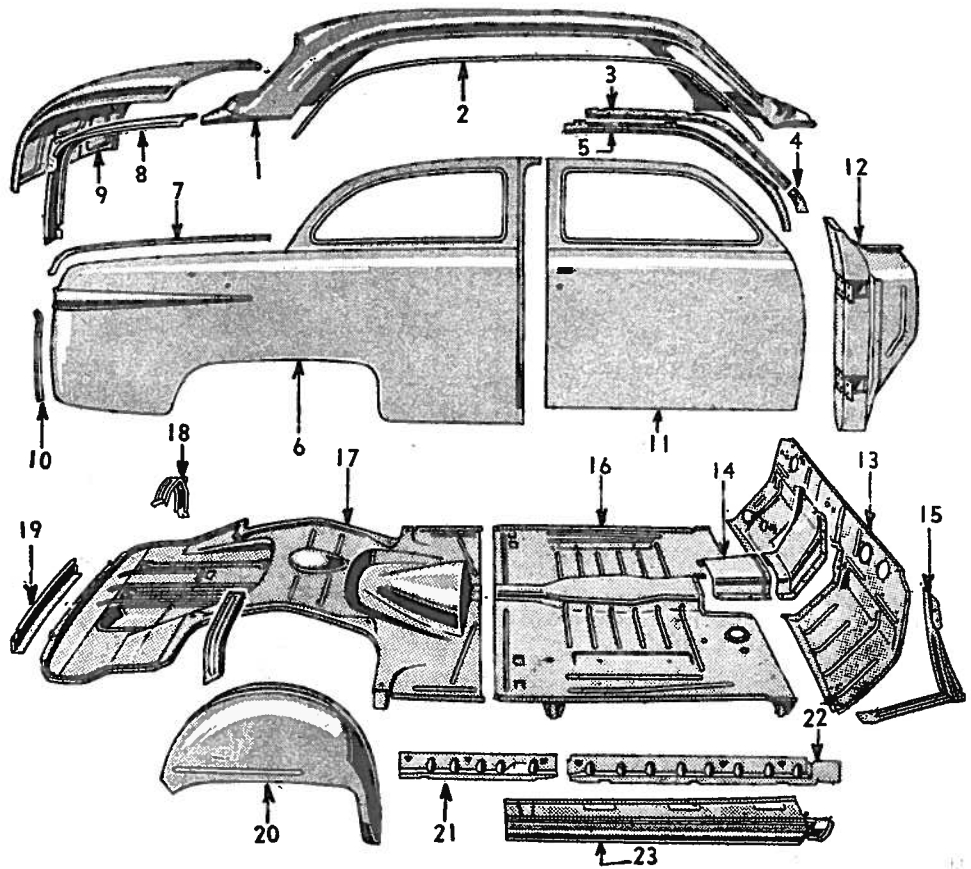

Fig. 10—Sheet Metal—Tudor & Coupes

* Opposite side one part number higher

BODY PARTS 1949 thru 1951 FORD

Models 98BA, 98HA, 0BA, 0HA, 1BA and 1HA. ALL BODY STYLES

<p>18 LUGGAGE COMPT. SPARE WHEEL BRKT. 8A-7047070—1949-5076 1A-7047070—195173</p> <p>19 LOWER BACK PANEL 8A-7040324—1949 to 1951..... 2.40</p> <p>20 REAR QUARTER WHEELHOUSE PANEL 8A-7027882—1949 to 1951 (right) 7.11</p> <p>21 REAR BODY SIDE LOWER EDGE REINFMT. 8A-7020032—1949 to 1951 (right) 1.00</p> <p>22 FRONT BODY SIDE LOWER EDGE REINFMT. 8A-7020030—1949 to 1951 (right) 1.50</p> <p>23 BODY ROCKER PANEL 8A-7010130-B—1949 to 1951 (right) 2.61</p>	<p>3 HOOD TOP CENTER MLDG. 8A-16736—1949 to 1950..... .86 1A-16736—195184</p> <p>4 HEADLAMP ASSY. 8C-13002-B—1949, less bulb... 6.14 0A-13002-B—1950, less bulb & ring 6.14 1A-13002—1951, less bulb & ring 6.14</p> <p>SEALED BEAM BULB 09A-13007—1949 to 1951..... 1.43</p> <p>5 HEADLAMP DOOR 0A-13045-C—1949-50 2.15 1A-13045-B—1951 2.59</p> <p>6 WDSHD. CENTER WTHSTP. OUTER RETAINER 8A-7003078-A—1949 to 1951, 70A, grey 1.83 8A-7003078-B—1949 to 1950, 70B 1.83 0A-7003078—1950-51, 70B, C.. 1.83</p> <p>7 WDSHD. GLASS 8A-7003100—1949-50 12.92</p> <p>8 WDSHD. FINISH OUTER MLDG. 8A-7003088-B—1949-50, 70B (right) 2.19 0A-7003088—1950-51, double groove 2.53</p> <p>9 WDSHD. WTHSTP. SA-7003110-D—1949 to 1951, 70A 5.53 8A-7003100-E—1949-50, 70B... 5.76 0A-7003110—1950-51, 70B, C.. 4.97</p> <p>10 DOOR VENT. WINDOW ASSY. 8A-7021406-A—1949 (right)... 6.54 8A-7021406-C—1950-51 (right) 6.54</p>	<p>11 DOOR VENT. GLASS 8A-7021412-B—1949 to 1951... 2.74</p> <p>12 ROOF DRIP MLDG. 8A-7051700—1949 to 1951..... .88</p> <p>13 DOOR GLASS 8A-7021410-A—1949 to 1951.. 7.32</p> <p>14 DOOR REVEAL MLDG. AND WTHSTP. 8A-7020934-B—1949 (right)... 3.36 0A-7020934-A—1950-51 (right) 3.05</p> <p>15 QUARTER WINDOW REVEAL MLDG. & WTHSTP. 8A-7029058-B—1949 (right) .. 3.36 0A-7029058—1949 to 1951 (right) 3.26</p> <p>16 QUARTER WINDOW GLASS 8A-7029710-A—1949 to 1951... 6.31</p> <p>17 QUARTER WINDOW REVEAL MLDG. JOINT COVER 8A-7020925-B—1949 to 1951.. .03</p> <p>18 COMPLETE QUARTER VENT. WINDOW 0A-7030203-A—1949-50, 70B (right) 11.20 0A-7030203-D—1951, 70B, C (right) 15.61</p> <p>19 QUARTER VENT GLASS 8A-7030210-B—1949 to 1951, 70B, C 2.68</p> <p>20 BACK WINDOW GLASS 8A-7042006—1949 to 1951..... 16.84</p> <p>21 BACK WINDOW GLASS WTHSTP. 8A-7042084-E—1949 to 1951, 70A 3.78 8A-7042084-D—1949-50, 70B .. 3.78 0A-7042084-B—1950-51, 70B, C 3.76</p>
---	---	--

continued

Moldings & Trim

Body Types—70A, B, C, 72A, B

See Fig. 11

<p>1 FRONT HOOD EMBLEM 8A-16606-A—1949, "F"33 8A-16606-B—1949, "O"45 8A-16606-C—1949, "R"45 8A-16606-D—1949, "D"33 0A-16637—1949 to 1951, plastic 1.16 0A-16607—1950, "Ford"52 0A-16644, 1949 to 1951, frame .52</p> <p>2 HOOD TOP ORNAMENT 8A-16850—1949 4.83 0A-16850—1950 4.83 1A-16851—1951 4.93</p>
--

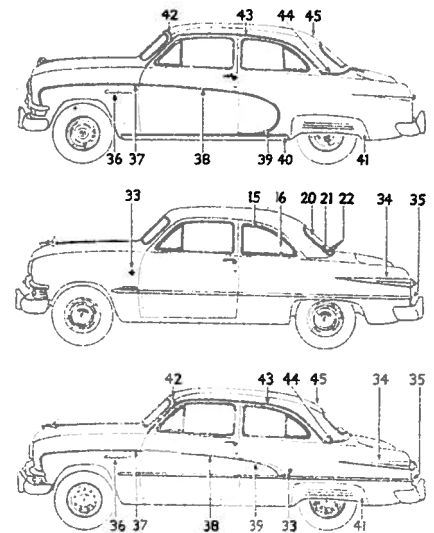
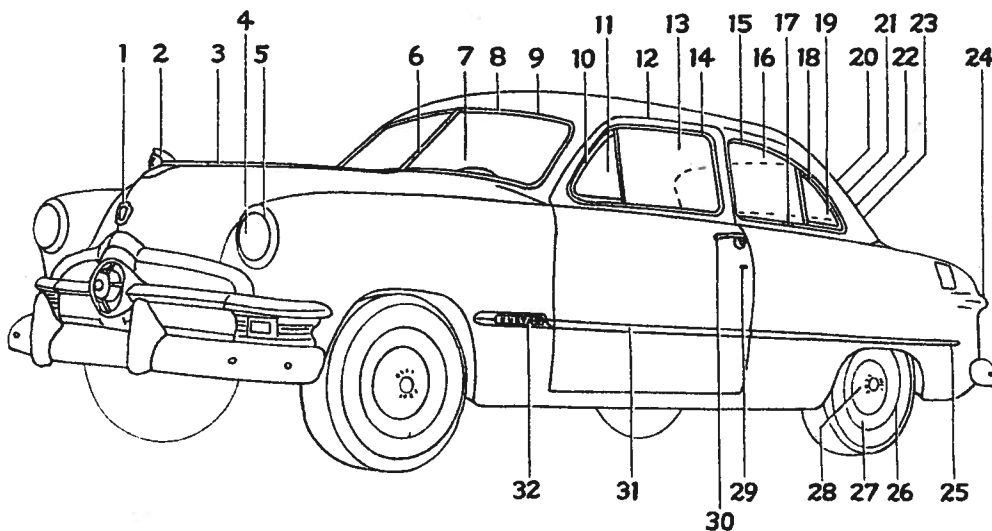

Fig. 11—Moldings and Trim

* Opposite side one part number higher

FORD 1949 thru 1951 BODY PARTS

Models 98BA, 98HA, 0BA, 0HA, 1BA and 1HA. ALL BODY STYLES

Moldings & Trim— continued

21 BACK WINDOW OUTER MLDG. 0A-7042430—1949 to 1951.....	2.19
22 BACK WINDOW OUTER MLDG. JOINT COVER 8A-7042432-B—1949 to early 1950, 70B05
8A-7042432-C—1950 late, to 1951, 70B, C.....	.07
22 BACK WINDOW OUTER CENTER LOWER MLDG. 1A-7242404-B—1951, 72B79
22 BACK WINDOW OUTER LOWER COR. 1A-7042472-B—1951, 70B (right)	1.21
1A-7242472-B—1951, 72B (right)	1.14
23 LUGGAGE COMPT. DOOR HINGE 8A-7042700-A—1949 (right) ..	1.95
8A-7042700-B—1950 (right) ..	1.95
1A-7042700-B—1951	1.97
24 REAR LAMP ASSY. 8A-13404-A—1949 to 1950....	4.40
1A-13404—1951 (right).....	7.22
25 QUARTER PANEL OUTER MLDG. 8A-7029038-B—1949-50 (right)	2.05
1A-7029038-B—1951 (right)...	2.07
26 WHEEL ASSY. 8A-1015-C—1949 to 1951 (6.00 x 16 tires).....	7.72
8A-1015-D—1949 to 1951 (7.10 x 15 tires).....	7.72
27 WHEEL TRIM RINGS (Set of 5) 8A-18303-A—1949 to 1951 (16" wheel)	11.65
8A-18303-B—1949 to 1951 (15" wheel)	11.65
28 HUB CAP 8A-1130-B—1949 to 1950	2.93
0A-1130—1950, 70C	7.12
1A-1130A—1951	2.93
1A-1130-B—1951, 70C	7.12
29 DOOR PILLAR LOCK & SLEEVE ASSY. 0A-7021984-B—1949 to 1950 (right)	1.88
1A-7021984—1951 (right).....	1.93
30 DOOR OUTER HANDLE 8A-7022400-A—1949	2.67
0A-7022400-A—1950-51 (right)	2.16
31 DOOR OUTER MLDG. 8A-7020938—1949-50, 70A, B, 72 (right)	2.28
0A-7020938—1950-51, 70C (right)	2.14
1A-7020938—1951, 70B, C, 72B (right)	2.19

32 FRONT FENDER MLDG. 8A-16188-A—1949	1.19
0A-16188-A—1950	1.19
1A-16188-B—1951, "Custom" ..	1.19
1A-16188-C—1951, "Deluxe"...	1.19
33 FRONT FENDER SIDE EMBLEM 1BA-16237—1951, "V8"79
34 QUARTER UPPER MLDG. OUTER 1A-7029028—1951 (right)	2.98
35 QUARTER PANEL EXTEN. MLDG. LOWER 1A-7029078—1951 (right).....	.67
36 FRONT FENDER MLDG. (Crestliner) 0A-16079—1950-51	1.57
37 FRONT FENDER MLDG. 0A-16003—1950 (right)	1.91
1A-16003—1951 (right)	1.88
38 DOOR MLDG. 0A-7020938—1950-51, 70C	2.14
39 QUARTER PANEL MLDG. 0A-7029038—1950, 70C	1.71
1A-7029038-B—1951, 70C	2.07
40 ROCKER PANEL MLDG. 0A-7010176—1949 to 1951 (right)	4.14
41 QUARTER PANEL WHEEL COVER 8A-7027968—1949 to 1951	9.22
42 FRONT ROOF COVER RETAINER MLDG. 0A-7053716—1950-51, 70C	2.05
43 ROOF DRIP MLDG. 8A-7051700—1949 to 1951, 70..	.88
8A-7251700—1949 to 1951, 72..	1.54
44 ROOF PANEL FINISH MLDG. 0A-7051734—1950-51, 70C	1.11
45 ROOF COVER ASSY. 0A-7053700-AU—1950-51, 70C black	40.24

0A-7053700-AX—1950-51, 70C brown	40.2
1A-7053700-AZ—1951, 70C, tan	40.2

Moldings & Trim

Body Types—60, 76—Conv. & Victoria

See Fig. 12

1 WDSHD. CENTER WTHSTP. OUTER RETAINER 8A-7603078-A—1949, 76	1.7
0A-7603078—1950-51, 76; 1951, 609
2 WDSHD. GLASS 8A-7603100—1949 to 1951	12.7
3 WDSHD. OUTER FINISH MLDG. 8A-7603088-B—1949-50, 76....	1.8
0A-7603088—1950-51, 76; 1951, 60	1.6
4 WDSHD. WTHSTP. 8A-7603110-B—1949-50, 76	5.8
0A-7603110—1950-51, 76; 1951, 60	5.5
5 FRONT BODY PILLAR DRIP MLDG. 0A-7602512—1950, 76 (right)..	1.4
1A-7602512—1951, 76 (right)..	1.4
1A-6002512-A—1951, 60 (right)	1.2
6 DOOR VENT. WINDOW (Complete) 8A-7621402-A—1949, 76 (right)	32.0
0A-7621402-A—1950 early, 76 (right)
0A-7621402-B—1950 late to 1951, 76; 1951, 60 (right)....	29.8
7 FRONT DOOR VENT. ASSY. 8A-7621406-A—1949, 76 (right)	9.6
8A-7621406-C—1950-51, 76, 60 (right)	9.6
8 FRONT DOOR VENT. GLASS 8A-7621412-A—1949, 76
8A-7621412-B—1950-51, 76; 1951, 60	3.2

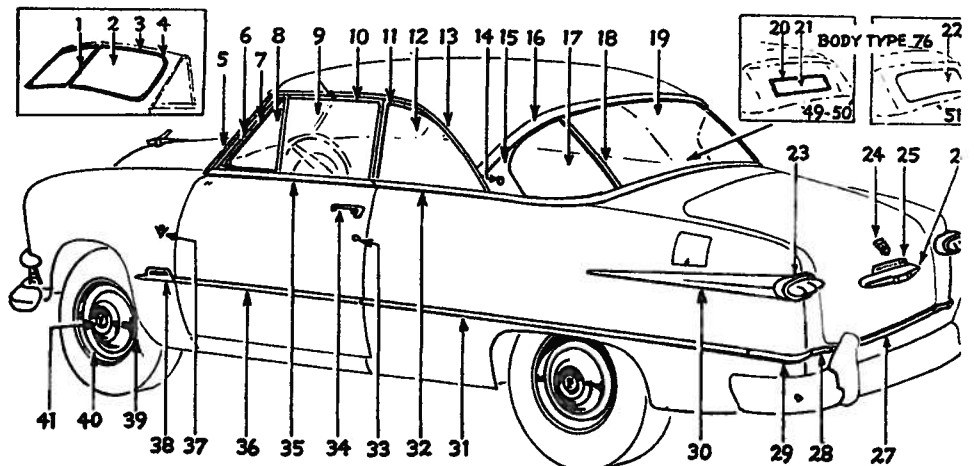

Fig. 12—Moldings & Trim

* Opposite side one part number higher

BODY PARTS 1949 thru 1951 FORD

Models 98BA, 98HA, 0BA, 0HA, 1BA and 1HA. ALL BODY STYLES

9 DOOR GLASS & FRAME ASSY. 8A-7622218—1949 to 1951, 76; 1951, 60 (right)	16.81
10 FRONT DOOR GLASS 8A-7621410-A—1949 to 1951, 76; 1951, 60.....	6.34
11 QUARTER WINDOW TOP & SIDE CHANNEL 8A-7629962—1949-50, 76	10.06
1A-7629962—1951, 60, 76	9.98
12 QUARTER WINDOW GLASS 8A-7629710-A—1949 to 1951, 76	6.09
1A-7629710-A—1951, 60, 76...	6.16
13 ROOF SIDE DRIP MLDG. 1A-6051726-B—1951, 60 (right)	1.18
14 ROOF SIDE ORNAMENT ASSY. 1A-6050268—1951, 6008
15 ROOF SIDE ORNAMENT PANEL 1A-6050254-B—1951, 60 (right)	2.49
16 BACK WINDOW UPPER OUTER MLDG. 1A-6042408-A—1951, 60
1A-6042408-D—1951, 60	13.22
17 BACK WINDOW SIDE GLASS 1A-6042026-B—1951, 60	5.85
18 BACK WINDOW DIV. BAR OUTER MLDG. 1A-6042420—1951, 6042
19 BACK WINDOW CENTER GLASS 1A-6042006-B—1951, 60	16.88
20 BACK GLASS FRAME 8M-7653220—1949-50, 76, outer	8.64
8M-7653224-AB — 1949-50, 76, inner	1.63
21 BACK WINDOW GLASS 8A-7653200—1949-50, 76	8.64
1A-7653200-B—1951, 76	8.64
22 SEE ITEM NO. 21	
23 REAR LAMP ASSY. 8A-13404-A—1949-50	4.40
1A-13404—1951 (right)	7.22
24 LUGGAGE COMPT. DOOR ORNAMENT 0A-7042514-B—1950, 76	1.24
0A-7042522-BZ8—1950-51, frame79
25 LUGGAGE COMPT. DOOR NAME PLATE 1A-7042528—1951 "Ford-o- Matic"75
26 LUGGAGE COMPT. DOOR HANDLE MLDG. 1A-7043530-B—1951	4.38
27 LOWER BACK PANEL MLDG. 1A-7040372—195186

28 QUARTER PANEL EXTEN. LOWER MLDG. 1A-7029078—1951 (right)67
29 QUARTER PANEL LOWER REAR OUTER MLDG. 1A-7029098—1951 (right)78
30 QUARTER PANEL OUTER UPPER MLDG. 1A-7029028—1951 (right).....	2.98
31 QUARTER OUTER MLDG. 8A-7029038-B—1949-50 (right)	2.05
1A-7029038-B—1951 (right)...	2.07
32 QUARTER BELT MLDG. 1A-6029022-B—1951, 60 (right)	3.06
1A-7629022-B—1951, 76 (right)	2.88
33 DOOR PILLAR LOCK & SLEEVE (2 keys) 0A-7021984-B—1949-50, 76 (right)	1.88
1A-7021984—1951 (right)	1.93
34 OUTER DOOR HANDLE 8A-7622400-A—1949, 76	1.71
0A-7622400-A—1950-51	2.14
35 DOOR BELT MLDG. 1A-6021010—1951 (right)	5.19
36 DOOR MLDG. 1A-7020938—1951 (right)	2.19
37 FRONT FENDER SIDE EMBLEM 1BA-16237—1951 "V8"79
38 FRONT FENDER MLDG. 1A-16188-E—1951 "Victoria"..	1.02
39 WHEEL ASSY. 8A-1015-C—1949 to 1951 (16 x 6.00 tires)	7.72
40 WHEEL TRIM RINGS 8A-18303-A—1949 to 1951 (set of 5)	11.65
41 WHEEL HUB CAP 8A-1130-B—1949-50	2.93
1A-1130-A—1951	2.93

4 GLASS RETAINING STRIP 8A-7629724-A—1949 to 1950... 1.60 1A-7629724—1951	1.21
5 QUARTER WINDOW WTHSTP. FRONT RETAINER 8A-7629982-D—1949 to 1950... .48	
5 QUARTER WINDOW WTHSTP. REAR RETAINER 8A-7629980-B—1949 to 1950 (right)97
6 FRONT QUARTER WINDOW WTHSTP. 8A-7630106—1949-50 (right) . 1.79 1A-7630146-A—1951 (right).. 1A-7630146-C—1951 (right)...	1.55
7 QUARTER WINDOW FRONT LOWER COR. 8A-7629746-A—1949 to 1950... .22	
8 QUARTER WINDOW HINGE PIN 21A-7630556—1949 to 1950.... .13	
9 QUARTER WINDOW HINGE 21A-7629948-B—1949 to 1951.. 3.22	

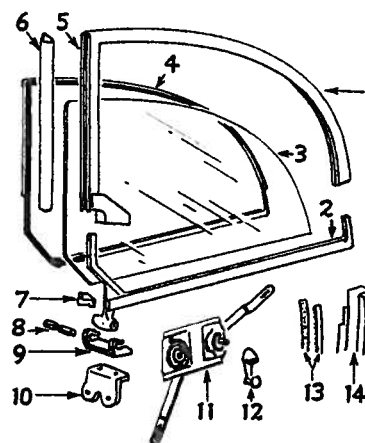

Fig. 13

Quarter Window

Body Style—76—Convertible

See Fig. 13

COMPLETE GLASS & FRAME ASSY.
8A-7629700—1949 (right)..... 28.81

1 TOP & SIDE QUARTER WINDOW CHANNEL 8A-7629962—1949 to 1950.....	10.06
2 QUARTER WINDOW LOWER CHANNEL 8A-7629958-A—1949 (right)...
8A-7629958-B—1950 (right)...	3.69
1A-7629958—1951 (right)	3.73
3 QUARTER WINDOW GLASS 8A-7629710-A—1949 to 1950... 6.09 1A-7629710-A—1951	6.16

10 QUARTER WINDOW BRKT. 8A-7629932—1949 to 1951 (right)	1.68
11 QUARTER WINDOW REGULATOR 8A-7630306-B—1949 to 1950, square shaft (right)..... 3.91 1A-7630306—1951, round shaft (right)	3.40
12 QUARTER WINDOW HANDLE 8A-7630322-B—1949, chrome knob	1.02
0A-7630322—1950, ivory knob. 1.02 1A-7630322—1951	1.00
13 QUARTER WINDOW GUIDE WTHSTP. 8A-7629750-B—1949 to 1951... ..	
14 QUARTER WINDOW GUIDE 8A-7629764—1949 to 1951 (right)	5.25

* Opposite side one part number higher

FORD 1949 thru 1951 BODY PARTS

Models 98BA, 98HA, 0BA, 0HA, 1BA and 1HA. ALL BODY STYLES

Sheet Metal & Fuel Tank

Body Type—76—Convertible

See Fig. 14

1 FRONT BODY ASSY.	
0A-7600120-A—1949-50	104.28
1A-7600120—1951	103.01
2 DASH TO FRAME SUPT. & BRACKET	
8A-7001790-B—1949-50 (right) ..	1.96
1A-7001790—1951 (right)	1.96
3 NOT LISTED	
4 QUARTER & SIDE PANEL ASSY.	
8A-7627840-D—1949 (right) ...	47.36
0A-7627840-C—1950 (right) ..	47.36
1A-7627840-H—1951 (right) ..	35.58
5 UPPER BACK PANEL ASSY.	
8A-7640310-B—1949
6 LUGGAGE COMPT. DOOR ASSY.	
0A-7040112-B—1949-50, less	
lock & hinges	38.35
1A-7040110—1951, less lock &	
hinges	39.88
7 QUARTER PANEL EXTEN.	
0A-7027934—1949 to 1951	
(right)	3.00
8 QUARTER PANEL EXTEN. UPPER	
MLDG.	
0A-7629052—1949-50 (right) ..	.84
1A-7629052-A—1951 (right) ..	.82
9 QUARTER PANEL EXTEN. MLDG.	
LOWER	
8A-7029080-B—1949-5024

10 DOOR ASSY. (Prime)	
8A-7620122-B—1949, w/hinges	
(right)	58.65
0A-7620122-B—1950, w/hinges	
(right)	58.65
1A-7620122—1951, w/hinges	
(right)	57.94
11 SPARE WHEEL MTG. BRKT. ASSY.	
8A-7047070—1949-5076
1A-7047070—195173
12 LOWER BACK PANEL	
8A-7040324—1949 to 1951	2.40
13 REAR FLOOR PAN ASSY.	
8A-7011215-B—1949
8A-7011215-C—1950	24.68
1A-7011215—1951	23.18
14 LUGGAGE COMPT. UPPER REINFMT.	
8A-7044822—1949 (right)34
1A-7044822—1951 (right)	1.48
15 WHEELHOUSE PANEL	
8A-7627882-B—1949-50 (right)	9.43
1A-7627882—1951 (right)	9.44
16 BODY SIDE LOWER EDGE REAR	
REINFMT.	
8A-7020032—1949 to 1951	
(right)	1.00
17 FLOOR TRANS. COVER REAR PLATE	
8A-7012120-A—1949	1.03
8A-7012120-B—1950	1.03
18 FLOOR TRANS. COVER FRONT	
PLATE	
8A-7012115-A—1949	1.78

19 FRONT FLOOR PAN ASSY.	
8A-7611135-C—1949-50, less	
center crossmember	13.6
0A-7611135-B—1950, w/center	
crossmember	15.6
1A-7611135-B—1951	15.8
20 BODY SIDE LOWER EDGE FRONT	
REINFMT.	
8A-7020030—1949 to 1951	
(right)	1.5
21 BODY ROCKER PANEL	
8A-7010130-B—1949 to 1951	
(right)	2.6
FUEL TANK ASSY.	
8A-9002-A—1949 to 1951, 17	
gal.	16.6

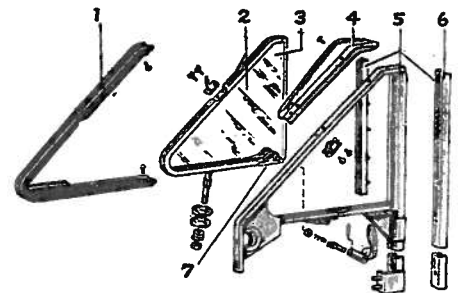

Fig. 15

Ventilator Window—Convertible

See Fig. 15

DOOR VENT. WINDOW ASSY.	
(Complete)	
8A-7621402-A—1949 (right) ...	32.00
0A-7621402-A—1950 early	
(right)
0A-7621402-B—1950 late to	
1951 (right)	29.80
1 VENT. WINDOW WTHSTP.	
8A-7621448-B—1949 to early	
1950 (right)	1.70
0A-7621448—1950 late to 1951	
(right)	1.40
2 DOOR VENT. WINDOW ASSY.	
8A-7021406-A—1949 (right) ...	6.50
8A-7621406-C—1950 to 1951	
(right)	9.60
3 DOOR VENT. GLASS	
8A-7621412-A—1949	3.20
8A-7621412-B—1950-51	3.20
4 DOOR VENT. RAIN SHIELD	
Not listed.	
5 DOOR VENT. RETAINER & DIV. BAR	
8A-7622204-A—1949 (right) ..	16.40
0A-7622204-A—1950 early	
(right)	16.40
0A-7622204-B—1950 late to	
1951	16.40

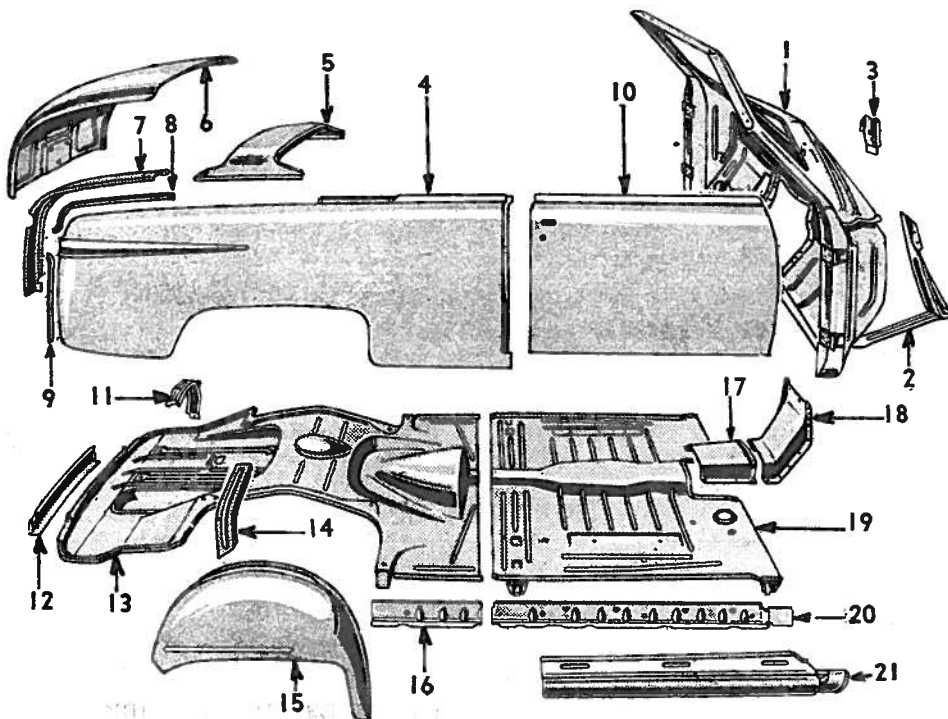

Fig. 14—Sheet Metal—Convertible

* Opposite side one part number higher

BODY PARTS 1949 thru 1951 FORD

Models 98BA, 98HA, 0BA, 0HA, 1BA and 1HA. ALL BODY STYLES

6 DOOR HINGE SIDE RUN	
8A-7621546—1949 to 195176
7 DOOR VENT. BRKT. & HANDLE SHAFT	
8A-7022938-A—1949 (right)39
8A-7022938-B—1950-51 (right)	.33

Convertible Folding Top

*Body Type—76—Convertible
See Fig. 16*

1 HEADER BRACKET PLATE	
8A-7653116—1949-5054
1A-7653116—195154
2 SIDE RAIL TO HEADER BRKT.	
8A-7650832-A—1949-50 (right)	2.43
1A-7650832-A—1951 (right) ..	2.43
3 FRONT CONTROL LINK NO. 2 BOW	
8A-7650434—1949-50 (right) ..	1.18
4 NO. 2 BOW BRKT.	
8A-7653166-B—1940 to 1950 (right)66
5 TOP SLAT LINK NO. 2 BOW	
8A-7650440—1949-50	1.18
6 REAR SIDE RAIL	
8A-7651154-C—1949-50 (right)	8.94
1A-7651154—1951 (right)	8.94
7 NO. 3 BOW BRKT.	
8A-7653144-B—1949-50 (right)	1.41
8 CONTROL LINK NO. 3 BOW	
8A-7650330-B—1949-5091
9 PILLAR REAR RAIL ASSY.	
8A-7653196-A—1949, less set screw (right)
8A-7653196-B—1940 to 1950, w/set screw (right)	8.29
1A-7653196—1951 (right)	8.29

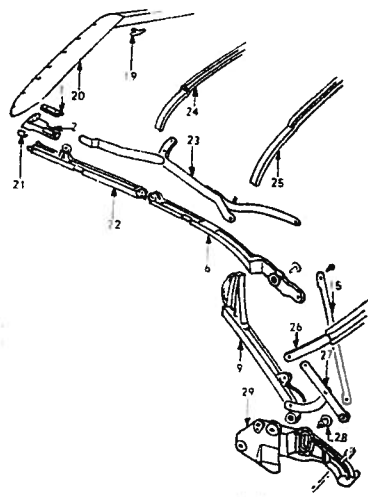

Fig. 16

10 TOP BOW SLAT REAR IRON	
8A-7650340-B—1949-50 (right)	1.63
1A-7650340—1951 (right)	1.12
11 PILLAR HINGE TO BODY BRKT. PLATE	
8A-7650398—1949 to 195112
12 MAIN PIVOT BRKT. TO SIDE RAIL BUMPER	
8A-7653179—1949 to 195106
13 TOP POWER LINK (Upper)	
8A-7650370—1949-5081
14 LOWER TOP POWER LINK	
8A-7650418—1949-5016
15 TOP BALANCE LINK	
8A-7650454—1949-50	1.63
1A-7650454—1951	1.63
16 FOLDING ARM REAR LINK	
8A-7650308—1949-50	1.63
17 SLAT IRON LINK	
8A-7650466—1949-50, No. 2 (right)97
18 SLAT IRON FOLDING ARM LINK	
8A-7650432—1949-50 (right) ..	.91
18 BOW SLAT REAR IRON	
8A-7650340-B—1949-50 (right)	1.63
1A-7650340—1951 (right)	1.12
19 TOP LOCKING HANDLE	
8H-7603570—1949 to 1951	2.61
20 HEADER ASSY.	
0A-7653038—1949 to 1951
1A-7653038—1951	25.98
21 HEADER BRACKET TO FRONT SIDE RAIL PLATE	
1A-7650484—195106
22 FRONT SIDE RAIL	
1A-7653104—1951 (right) ...	6.49
23 CONTROL LINK ASSY.	
1A-7650316—1951 (right)	7.60
24 BOW ASSY. NO. 2	
1A-7651274—1951	1.72
25 BOW ASSY. NO. 3	
1A-7651269—1951	1.72
26 REAR BOW ASSY. NO. 4	
8A-7651278-B—1949	10.31
0A-7651278—1950	10.31
1A-7651278—1951	10.39
27 POWER LINK	
1A-7650352—1951 (right)	2.67
28 BALANCE LINK ADJ. PIVOT	
1A-7650451—1951	1.56
29 MAIN PIVOT BODY BRKT.	
8A-7653118-A—1949-50 (right)	7.23
1A-7653118-A—1951 (right) . . .	7.23

* Opposite side one part number higher

**Top Lifting Mechanism
1949-50**

*Body Type—76—Convertible
See Fig 17*

1 CYLINDER YOKE ASSY.	
8A-7650774—1949-5070
2 CYLINDER ASSY.	
8A-7650601—1949-50, less yoke	7.47
3 CYLINDER TO FLOOR BRKT. SPACER	
96H-7650606—1949-5019
4 PRESSURE DOWN REAR TUBE ASSY.	
8A-7653390—1949-50 (right) ..	.76
5 PRESSURE UP REAR TUBE ASSY.	
8A-7653392—1949-50 (right) ..	.61
6 PRESSURE UP CENTER TUBE ASSY.	
8A-7650648—1949-50	1.95
7 PRESSURE DOWN CENTER TUBE ASSY.	
8A-7650649—1949-50	1.95
8 PRESSURE DOWN FRONT TUBE ASSY.	
8A-7653361-B—1949-5052

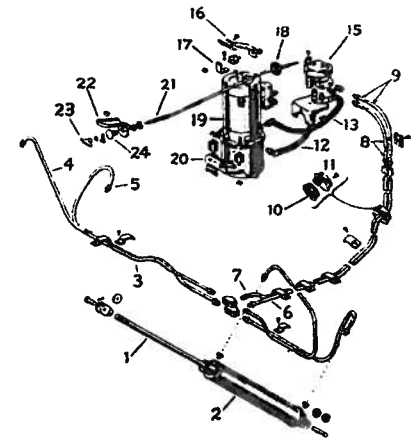

Fig. 17

9 PRESSURE UP FRONT TUBE ASSY.	
8A-7653363-B—1949-5052
10 TUBE GROMMET	
8A-14603—1949-5015
11 TUBE GROMMET RETAINER	
8A-14608—1949-5015
12 PUMP TO CONTROL VALVE RETURN HOSE	
8A-7653341—1949-50	1.50
13 PUMP TO CONTROL VALVE SUPPLY HOSE	
8A-7653342—1949-50	1.50
14 OPERATING VALVE BRKT.	
8A-7650686—1949-5033
15 OPERATING VALVE ASSY.	
5EH-7650738—1949-50	7.84

continued

FORD 1949 thru 1951 BODY PARTS

Models 98BA, 98HA, 0BA, 0HA, 1BA and 1HA. ALL BODY STYLES

Top Lifting Mechanism— continued

16 OPERATING MOTOR & PUMP UPPER BRKT. 8A-7650757—1949-5012
17 MOTOR MTG., CUSHION 5EH-7353384—1949-5007
18 LIFT MOTOR SUPPORT CUSHION 5EH-7353382—1949-5054
19 COMPLETE MOTOR & HYD. PUMP 8A-7650736—1949 to 1952	41.59
20 MOTOR & PUMP LOWER BRKT. 8A-7650759—1949-5043
21 CONTROL ROD & KNOB ASSY. 8A-7650570-B—1949-50	1.02
22 INSTRUMENT PANEL CONTROL BRKT. 8A-7650582—1949-5070
23 CONTROL KNOB 8A-7650640—1949-5079
24 CONTROL ESCUTCHEON 8A-7650578—1949-5045

Top Lifting Mechanism 1951

See Fig. 18

1 HYD. CYLINDER YOKE 1A-7650774—195170
2 CYLINDER ASSY. 8A-7650601—1951	7.47
3 LIFT TO LOCK PILLAR BRACE BRKT. 1A-7650764—1951	1.56
4 PRESSURE DOWN TUBE 1A-7653390—1951 (right)76
5 PRESSURE CENTER DOWN TUBE 1A-7650649-B—195151

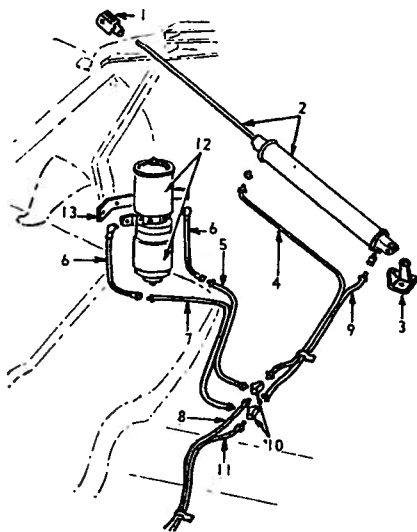

Fig. 18

6 PUMP TO CONTROL VALVE RETURN & SUPPLY HOSE 1A-7653342—1951	1.35
7 PRESSURE CENTER UP TUBE 1A-7650648-B—195151
8 SEE ITEM NO. 4	
9 PRESSURE UP TUBE ASSY. 1A-7653392—195191
10 PRESSURE UP TUBE TEE CONNECTOR	
11 SEE ITEM NO. 9	
12 COMPLETE MOTOR & PUMP ASSY. 1A-7650736—1951	52.79

Rear of Car

See Fig. 19

1 BACK WINDOW OUTER LOWER COR. MLDG. 1A-7042472-B—1951, 70B, 73B (right)	1.21
1A-7242472-B—1951, 72B (right)	1.14
2 BACK WINDOW OUTER LOWER CENTER MLDG. 1A-7042478—1951, 70B, 73B...	1.42
3 BACK WINDOW OUTER MLDG. 0A-7042430—1949 to 1951.....	2.19
BACK WINDOW GLASS WTHSTP. 8A-7042084-D—1949-50, 70B, 72B, 73B	3.78
8A-7042084-E—1949 to 1951, 70A, 72C, 73A	3.78
0A-7042084-B—1950-51, 70B, C, 72B, 73B	3.76
1A-6042084-A—1951, 60	8.86
4 BACK WINDOW OUTER MLDG. JOINT COVER 8A-7042432-B—1949-50, 70B, 2, 305
8A-7042432-C—1950-51, 70B, C, 72B, 307
1A-6042432—1951, 6009
5 LUGGAGE COMPT. DOOR HANDLE BASE PAD 8A-7043531—194917
1A-7043531—195119
6 LUGGAGE COMPT. DOOR HANDLE 8A-7043500-C—1949	4.72
0A-7043500-A—1950	3.86
1A-7043500—1951	2.41
7 LUGGAGE COMPT. DOOR HANDLE MLDG. 1A-7043530-B—1951	4.38
1A-7043530-C—1951	
8 COMPT. LOCK CYLINDER & KEYS 8A-7043505-A—1949	1.26
0A-7043505-A—1950	1.24
1A-7043505—1951	1.12

10 COMPT. DOOR LOCK BOLT LINK 0A-7043226-B—1950, w/o A-7043200-A0
0A-7043226-D—1950, w/o A-7043200-B0
1A-7043226-A—19510
1A-7043226-B—19510
11 COMPT. DOOR LOCK ASSY. 8A-7043200—1949	1.3
0A-7043200-A—1950
0A-7043200-B—1950, ice tong type5
1A-7043200—1951	2.6
12 COMPT. DOOR LOCK STRIKER PLATE 8A-7043252—1949 to early 1950, w/o A-7043200-A7
0A-7043252—1950, w/o A-7043200-B only4
1A-7043252-A—19515
1A-7043252-C—1951, material substitution6
13 COMPT. DOOR LOCK STRIKER BRKT. 1A-7043275-A—19511
14 COMPT. DOOR LOCK TRIGGER 0A-7043603-A—1950
15 COMPT. DOOR LOCK TRIGGER SPRING 11A-13031—19500
16 COMPT. DOOR LOCK GUARD 8A-7043554—1949-501
17 REAR LICENSE LAMP BODY ASSY 8A-13553-C—1949	2.8
18 COMPT. DOOR ORNAMENT 0A-7042514-B—1950	1.2
0A-7042522—Frame7
19 COMPT. DOOR NAME PLATE 1A-7042528—1951 "Ford-o-Matic Drive"7
20 COMPT. DOOR ASSY. (Less lock & hinges) 0A-7040112-B—1949-50	38.3
1A-7040110—1951	39.8
21 LICENSE LAMP WIRE ASSY. 7RA-13412—1949-50, exc. 79..	...
1A-13412—1951, exc. 795
22 SEE ITEM NO. 8	
23 LICENSE BRKT. 8M-13425—1949-50
0A-13425—1951	3.1
24 BACK PANEL LOWER MLDG. 1A-7040372—19518
25 QUARTER PANEL EXTEN. LOWER MLDG. 1A-7029078—1951 (right)6
26 QUARTER PANEL LOWER REAR MLDG. 1A-7029098-B—19517
27 REAR LAMP ASSY. 8A-13404-A—1949-50, exc. 79.	4.4

* Opposite side one part number higher

BODY PARTS 1949 thru 1951 FORD

Models 98BA, 98HA, 0BA, 0HA, 1BA and 1HA. ALL BODY STYLES

1A-13404—1951, exc. 79 (right) 7.22	0A-17997—1950, exc. 79 (right) 4.02	0A-17795—1950, exc. 79 (right) 1.72
8A-13402—1949 to 1951..... 4.20	1A-17984—1951, exc. 79 (right) 3.98	1A-17795-A—1951, exc. 79 (right) 1.34
28 QUARTER PANEL UPPER MLDG.	8M-17984-B—1951, 79 (right). 7.52	
1A-7029028—1951 (right) 2.98	33 REAR BUMPER IMPACT BAR	36 REAR BUMPER INNER ARM
29 COMPT. DOOR SUPT. ARM	8A-17906-A—1949, exc. 79.... 24.28	8A-17787-A—1949, exc. 79 (right) 1.79
8A-7044200-A—1949 1.36	0A-17906—1950, exc. 79..... 23.12	8A-17787-B—1949-50, 79 (right) 1.92
8A-7044200-B—1950 1.12	1A-17906-A—1951, exc. 79.... 26.62	0A-17787—1950, exc. 79 (right) 1.38
30 COMPT. DOOR HINGE ASSY.	8M-17906-B—1949 to 1951.... 19.50	1A-17787-A—1951, exc. 79 (right) 1.38
8A-7042700-A—1949, exc. 79 (right) 1.95	34 REAR BUMPER IMPACT BAR REINFMT.	1A-17787-C—1951, 79 (right). 1.95
8A-7042700-B—1950, exc. 79 (right) 1.95	1A-17912—1951, exc. 79 (right) 1.45	37 STONE DEFLECTOR SEALER
1A-7042700-B—1951, exc. 79 (right) 1.97	8A-17958—1949-50, 79 (right) 1.72	8A-17832-A—1949 to 1951, exc. 79 1.26
32 REAR BUMPER GUARD	1A-17958-B—1951, 79 (right). 2.01	
8A-17997-A—1949, exc. 79 (right) 4.02	35 REAR BUMPER OUTER ARM	38 REAR BUMPER STONE DEFLECTOR
	8A-17795-A—1949, exc. 79 (right) 1.79	8A-17801—1949-50, exc. 79.... 5.76
	8A-17795-B—1949-50, 79 (right) 1.92	1A-17801—1951, exc. 79 2.76
		8M-17808-B—1949 to 1951, 79. 4.57

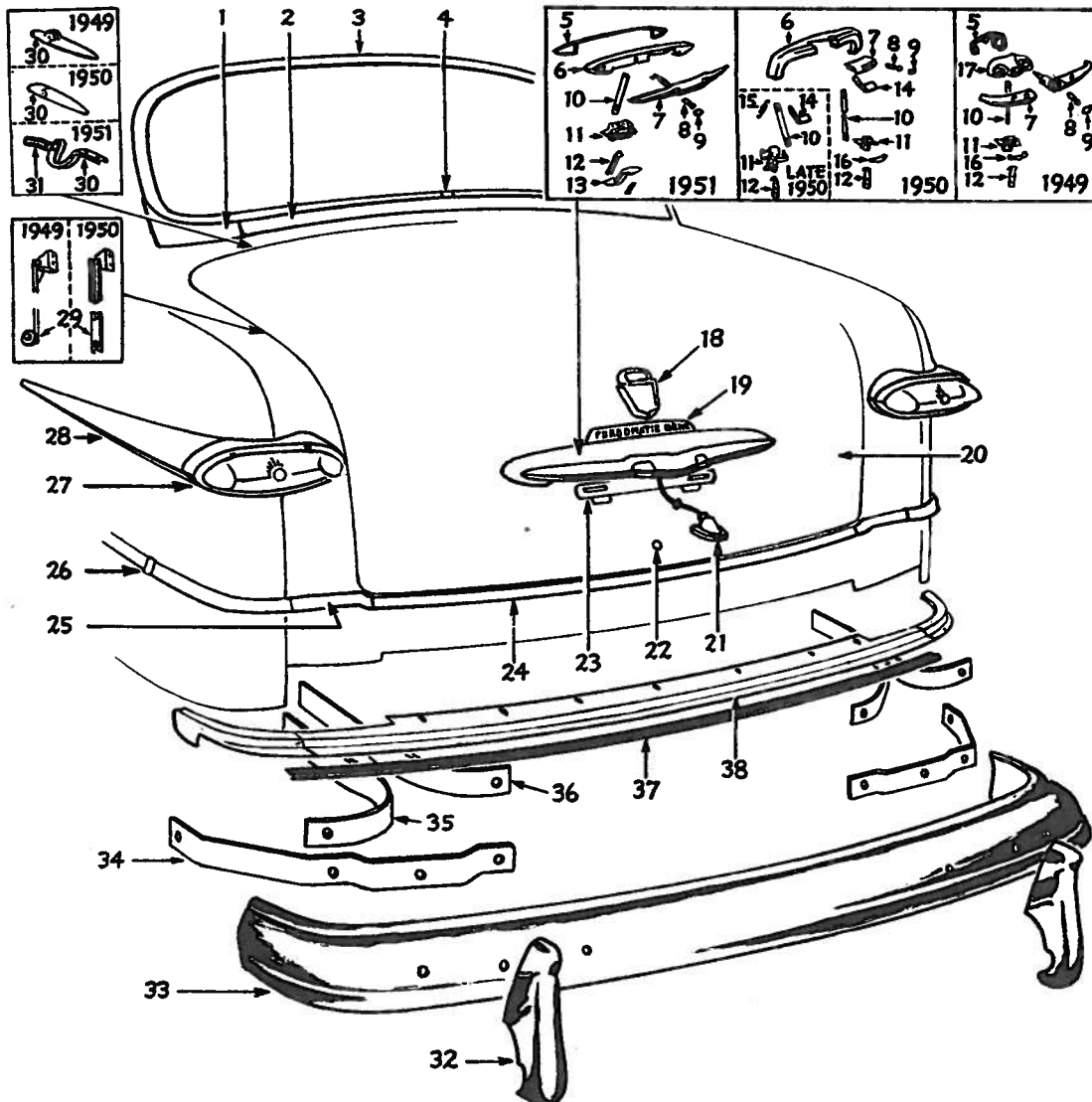

Fig. 19—Rear of Car

* Opposite side one part number higher

FORD 1949 thru 1951 BODY PARTS

Models 98BA, 98HA, 0BA, 0HA, 1BA and 1HA. ALL BODY STYLES

Front Suspension

1 UPPER ARM INNER SEAL 8M-3076—1949 to 1951.....	.11
2 UPPER SHAFT KIT 8A-3047—1949 to 1951.....	3.22
3 UPPER SHAFT TO FRAME BOLT 351096-S8—1949 to 1951.....	.26
4 ARM BUSHING LUBRICATOR 353031-A-S7—1949 to 1951.....
5 UPPER ARM BUSHING ASSY. 8A-3062-C—1949 to 1951.....	.44
6 UPPER ARM ASSY. 8A-3082—1949 to 1951.....	3.89
7 SPINDLE GREASE FITTING 353043-A-S7—1949 to 1951.....
8 UPPER SPINDLE SUPT. KIT 8A-3049—1949 to 1951.....	2.18
9 UPPER ARM OUTER SEAL 8A-3075—1949 to 1951.....	.11
10 SEE ITEM NO. 8	
11 COIL SPRING INSULATOR 8A-5415-A—1949 to 1951.....	.28
12 FRONT COIL SPRING 8A-5310-B—1949-50, exc. 76 (white marked)	6.45
0A-5310—1949-50, 76 (alum. marked)	6.45
8A-5310-D—1949-50, exc. 76 (yellow marked)	6.45
1A-5310-A—1951, exc. 76, 79 (yellow marked)	6.45
1A-5310-B—1951, 76 (red marked)	6.45
1A-5310-C—1951, 79 (blue marked)	6.45
13 REBOUND BUMPER 8A-3025—1949 to 1951.....	.28
14 SPINDLE BOLT & BUSHING KIT APA-3111-B—1949 to 1951 ...	4.78
15 SEE ITEM NO. 14	
16 SEE ITEM NO. 14	
17 SEE ITEM NO. 14	
18 SPINDLE SUPT. ASSY. 8A-3052-C—1949 to 1951 (right)	9.02
19 SPINDLE ARM TO STOP BOLT 355758-S7—1949 to 1951.....	.35
20 SPINDLE ASSY. 8A-3105-B—1949 to 1951.....	9.98
21 SPINDLE ARM TO SPINDLE BOLT 355635-S7—1949 to 1951.....	.19

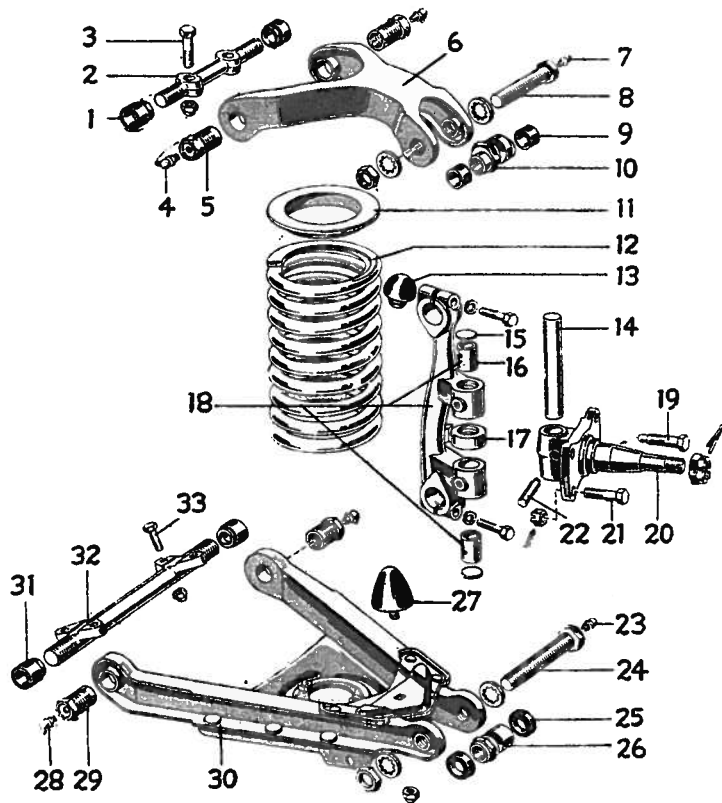

Front Suspension

22 SPINDLE BOLT LOCKING PIN 352655-S8—1949 to 1951.....	.13
23 SEE ITEM NO. 7	
24 LOWER ARM TO SPINDLE SUPT. BOLT 8A-3073—1949 to 1951 (part of 8A-3050 kit)
25 LOWER ARM OUTER SEAL 8A-3088-B—1949 to 1951.....	.11
26 SPINDLE SUPT. LOWER BUSHING 8A-3089-B—1949 to 1951.....	.56
27 LOWER ARM BUMPER 8A-3020-B—1949 to 1951.....	.31
28 SEE ITEM NO. 4	
29 LOWER ARM INNER BUSHING 8A-3063-A—1949 to 1951.....	.56
30 LOWER ARM ASSY. 8A-3078-B—1949, seat height 7/16 in.
8A-3078-C—1950-51, seat height 11/16 in.	5.73

31 LOWER ARM INNER SEAL 8M-3074—1949 to 1951.....	.1
32 LOWER SHAFT KIT 8A-3048—1949 to 1951.....	4.0
33 LOWER ARM SHAFT TO FRAME BOLT 350811-S7—1949 to 1951.....	.1

Frame Assembly

Except Body Type—79

1 FRAME ASSY. 0A-5005-A—1949-50, exc. 76... 0A-5005-B—1949-50, 76	102.51 145.71
2 RADIATOR LOWER SUPT. 0A-5071—1950	1.81
8A-5071—1949
1A-5071—1951	1.81
3 STEERING GEAR TO FRAME BRKT. 8A-5104—1949 to 1951.....	.21

* Opposite side one part number higher

BODY PARTS 1949 thru 1951 FORD

Models 98BA, 98HA, 0BA, 0HA, 1BA and 1HA. ALL BODY STYLES

4 ENGINE SUPT. & CROSSMEMBER NO. 2		
8A-5025-A—1949-50, exc. 76..	4.86	
8A-5025-C—1949-50, 71, 76....	4.71	

5 ENGINE SUPT. CROSSMEMBER (Box frame)		
8A-5060—1949 to 1951, exc. 76	.27	

6 INTERMEDIATE CROSSMEMBER		
1A-5028—1951, exc. 76.....	3.60	

7 FRONT BODY TO FRAME BRKT.		
8A-5075-B—1949-50 (right)...	.69	
0A-5075—1951 (right).....	.69	

8 BODY TO FRAME CENTER BRKT.		
8A-5088—1949 to 1951.....	.69	

9 BODY TO FRAME REAR BRKT.		
8A-5144—1949 to 1951.....	.90	

10 REAR CROSSMEMBER TO SIDE GUSSET		
8A-5031-A—1949 to early 1950 (right)	1.24	
0A-5031-B—1950 late (right)...	1.29	

11 REAR CROSSMEMBER		
8A-5035-A—1949-50	1.62	
1A-5035-A—1951	1.62	

12 FRONT CROSSMEMBER TO SIDE REINFMT		
0A-5091—1949-5063	
1A-5091—195163	

Frame

Body Style—79—Station Wagon

1 FRAME ASSY.		
8A-5005-E—1949-50	145.72	
1A-5005-C—1951	129.53	

2 RADIATOR LOWER SUPT.		
0A-5071—1950	1.86	
8A-5071—1949	
1A-5071—1951	1.86	

3 ENGINE REAR SUPT. & CROSSMEMBER		
8A-5025-C—1949	4.71	

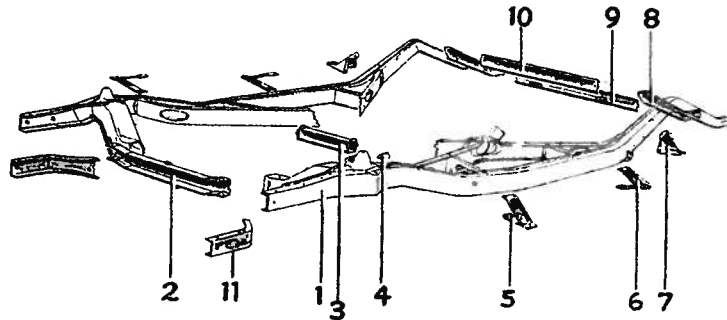

Frame—Body Style 79

4 STEERING GEAR TO FRAME BRKT.		
8A-5104—1949 to 1951.....	.27	

5 FRONT BODY TO FRAME BRKT.		
8A-5075-B—1949-50 (right)...	.69	
0A-5075—1951 (right)69	

6 BODY TO FRAME CENTER BRKT.		
8A-5088—1949 to 1951.....	.69	

7 BODY TO FRAME REAR BRKT.		
8A-5145—1949 to 1951.....	.91	

8 REAR SIDE MEMBER REINFMT.		
8A-5031-B—1949-50 (right)...	1.59	

9 REAR CROSSMEMBER		
8A-5035-B—1949-50	1.62	
1A-5035-B—1951	1.62	

10 REAR SHOCK ABSORBER CROSSMEMBER		
8A-5029—1949 to 1951.....	2.19	

11 FRONT CROSSMEMBER TO SIDE REINFMT.		
0A-5091—1949-5063	
1A-5091—195163	

STEERING GEOMETRY

1949-1951

CASTER: 1949 1/4 degree positive to 3/4 degree negative. 1950-51 1/2 degree positive to 1 degree negative.

CAMBER: 1949 1/4 degree negative to 3/4 degree positive. 1950-51 0 to 1 degree positive.

TOE-IN: 1/16 to 1/8 inch.

TOE-OUT TURNS (TURNING RADIUS): Outer Wheel 20 degrees. Inner Wheel 20 1/2 degrees.

KING PIN INCLINATION: 5 1/2 degrees.

ADJUSTMENTS

CASTER: Is adjusted at the lower control bushing. Turning bushing towards rear of car will decrease caster. Turning towards front of car will increase caster.

CAMBER: Is adjusted at the upper support arm outer bushing.

TOE-IN: Centralize steering and adjust both tie rods to give correct toe-in.

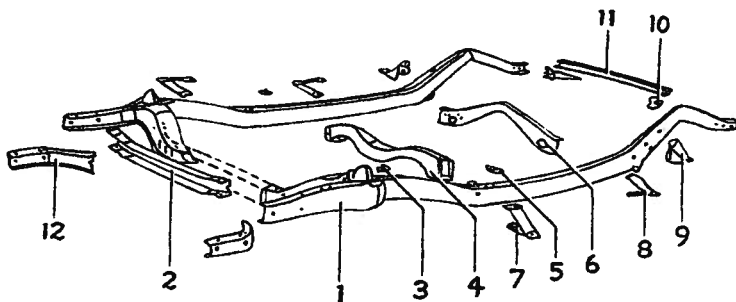

Frame Assembly. All Except Body Type 79

* Opposite side one part number higher

FORD 1949 thru 1950 FRAMES

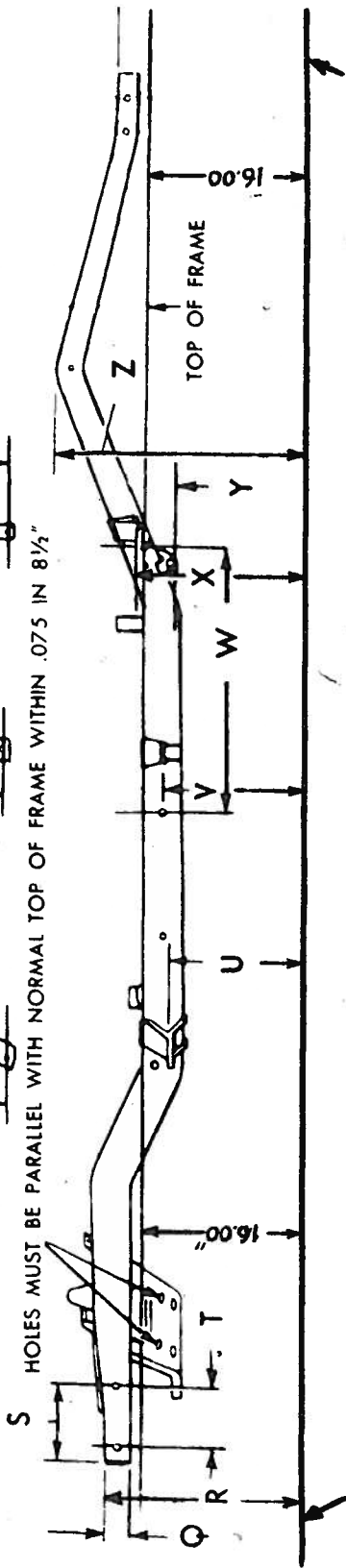
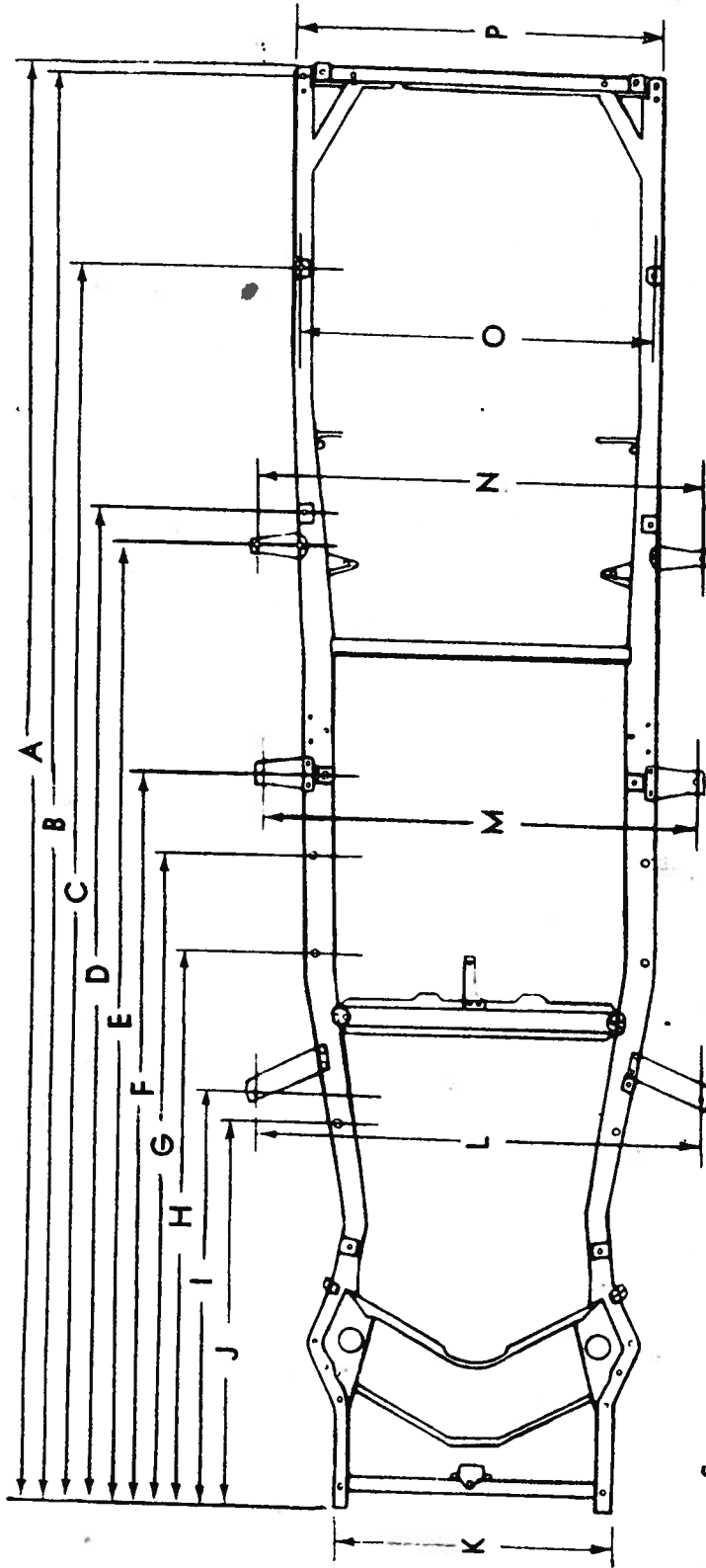

SUPPORT THE FRAME ON JACKS TO LOCATE THE TOP OF THE SIDE RAILS EXACTLY 16 INCHES FROM A LEVEL WORK SURFACE

Dimension Point

Model and Series	A	B	C	D	E	F	G	H	I	J	K	L	M	N	O	P	Q	R	S	T	U	V	W	X	Y	Z
1949-1950 Sedan and Coupe	1767/16	1755/8	1513/4	1231/32	1195/32	911/16	8029/32	6823/32	531/32	515/32	34	5617/32	549/16	55	42	44	31/2	197/8	71/4	6	131/8	137/32	307/16	133/8	271/32	1813/32
1949-1950 Convertible Coupe	1767/16	1755/8	1513/4	1195/32	903/4	7813/32	6821/32	515/32	495/8	34	5617/32	549/16	55	42	44	3	197/8	71/4	6	137/16	137/16	307/16	133/8	27	1831/32

FRAMES 1951 thru 1953 FORD

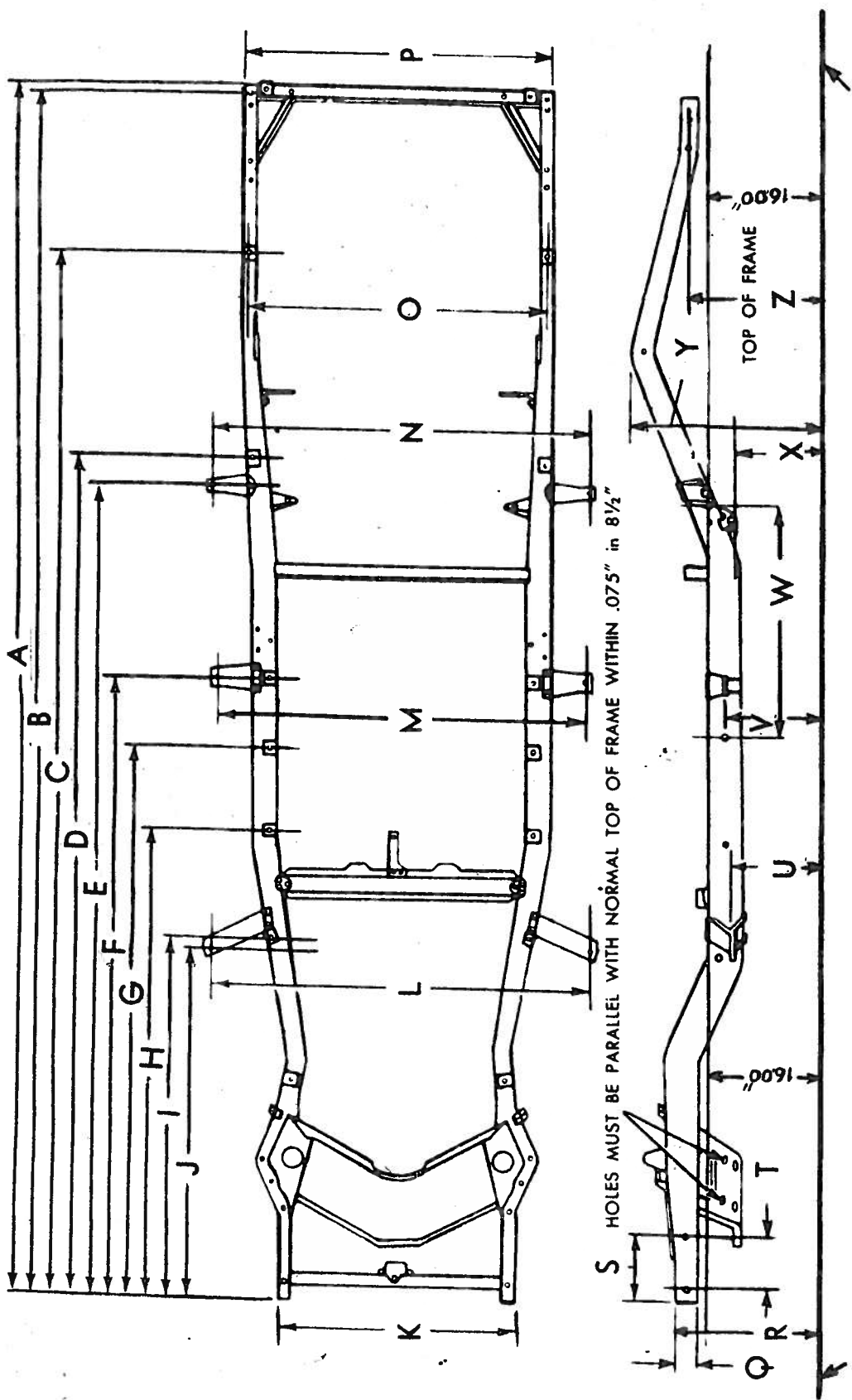

SUPPORT THE FRAME ON JACKS TO LOCATE THE TOP OF THE SIDE RAILS EXACTLY 16 INCHES FROM A LEVEL WORK SURFACE

Dimension Point

Model and Series	A	B	C	D	E	F	G	H	I	J	K	L	M	N	O	P	Q	R	S	T	U	V	W	X	Y	Z
1951 Sedan and Coupe	176 ⁷ / ₁₆	175 ⁵ / ₈	151 ³ / ₄	123 ¹ / ₂	119 ⁵ / ₃₂	91 ¹ / ₈	78 ³ / ₃₂	88 ² / ₃₂	51 ⁵ / ₃₂	49 ⁵ / ₈	34	56 ¹ / ₃₂	54 ⁹ / ₁₆	55	42	44	3	19 ⁷ / ₈	7 ¹ / ₄	6	13 ⁷ / ₁₆	13 ¹ / ₂	30 ⁷ / ₁₆	17 ¹ / ₁₆	13 ³ / ₈	27
1951 Convertible Coupe	176 ⁷ / ₁₆	175 ⁵ / ₈	151 ³ / ₄		119 ⁵ / ₃₂	96 ³ / ₄	80 ² / ₃₂	88 ² / ₃₂	51 ⁵ / ₃₂	53 ¹ / ₃₂	34	56 ¹ / ₃₂	54 ⁹ / ₁₆	55	42	44	3	19 ⁷ / ₈	7 ¹ / ₄	6	13 ⁷ / ₁₆	13 ¹ / ₂	30 ⁷ / ₁₆	17 ¹ / ₁₆	13 ³ / ₈	27
1952-1953 Convertible Coupe	179 ¹ / ₁₆	175 ⁵ / ₈	152 ¹ / ₄		111 ⁴ / ₆₄	88	69 ⁵ / ₆₄		51 ¹ / ₁₆	39 ¹ / ₃₂	35 ¹ / ₁₆	49 ¹ / ₁₆	51	53 ⁵ / ₈	39 ¹ / ₁₆	44 ¹ / ₄	3 ¹ / ₃₂	25	6 ³ / ₄	6	15 ³ / ₁₆	14 ⁷ / ₈	40 ⁵ / ₁₆	17 ¹ / ₄	13 ⁷ / ₈	26 ¹ / ₂
1952-1953 Station Wagon	179 ⁵ / ₁₆	175 ⁵ / ₈	152 ¹ / ₄	125 ² / ₃₂	111 ⁴ / ₆₄	88	69 ⁵ / ₆₄		51 ¹ / ₁₆	39 ¹ / ₃₂	35 ¹ / ₁₆	49 ¹ / ₁₆	51	53 ⁵ / ₈	36 ¹ / ₄	44 ¹ / ₄	3 ¹ / ₃₂	21	6 ³ / ₄	6	15 ³ / ₁₆	14 ⁷ / ₈	40 ⁵ / ₁₆	14 ¹ / ₂	12 ⁷ / ₈	26 ¹ / ₂
1952-53 Sed., Cpe., Hard Top	179 ¹ / ₁₆	175 ⁵ / ₈	152 ¹ / ₄	125 ² / ₃₂	111 ⁴ / ₆₄	88	69 ⁵ / ₆₄		51 ¹ / ₁₆	39 ¹ / ₃₂	35 ¹ / ₁₆	49 ¹ / ₁₆	51	53 ⁵ / ₈	39 ¹ / ₁₆	44 ¹ / ₄	3 ¹ / ₃₂	21	6 ³ / ₄	6	15 ³ / ₁₆	14 ⁷ / ₈	40 ⁵ / ₁₆	14 ³ / ₄	12 ⁷ / ₈	26 ¹ / ₂