

DODGE 1949 thru 1953 BODY PARTS**ALL BODY STYLES****Front End of Car**

See Fig. 1

1 HOOD PANEL ASSY.					
1309173—1949	41.31				
1335243—1950	41.31				
1346546—1951-52	41.31				
1456567—1953, D44	41.31				
1434651—1953, D46	41.31				
1456718—1953, D47	41.30				
1456706—1953, D48	41.31				
2 HOOD TOP MOLDING					
1298954—1949-50	2.22				
1347293—1951-52	2.10				
3 HOOD TOP ORNAMENT					
1298935—1949-50	7.95				
3 ORNAMENT BASE					
1373215—1951	5.01				
1456355—1952	7.65				
1456250—1953	6.25				
3 ORNAMENT, HORN					
1373213—1951-52 (right*) ...	3.75				
1373283—1953 (right*)				
4 HOOD FRONT MOLDING					
1240680—1949	3.75				
1335241—1950	3.35				
1347354—1951-52, front joint.	.74				
1494102—1953, D47, 48	3.93				
1494098—1953, D44, 46 (fdr.					
ext.) (right*)				
1494103—1953, D47, 48 (fdr.					
ext.) (right*)				
5 HOOD FRONT MEDALLION					
1243366—1949, D30	3.32				
1434814—1951-52	2.98				
1456378—1953, D46	2.95				
1456607—1953, D47	2.95				
1456697—1953, D44	1.85				
1456699—1953, D48	1.85				
6 HOOD FRONT NAME LETTER					
1241342—1949, letter (D)45				
1241343—1949, (O)45				
1241344—1949, (D) center45				
1241345—1949, (G)45				
1241346—1949, (E)45				
1335578—1950 to 52, letter (D)	.50				
1335579—1950 to 52, (O)50				
1335580—1950, (D) center50				
1335581—1950 to 52, (G)50				
1335582—1950 to 52, (E)50				
1346890—1951-52, (D) center.	.50				
6 HOOD FRONT NAME LETTER					
CLIP					
1298200—194903				
445157—1950 to 52, single clip	.03				
1335589—1950 to 52, letter					
double clip03				
7 HOOD HINGE					
1256117—1949 (right*)	7.25				
1306799—1950 (right*)	7.25				
1347366—1951-52 (right*) ...	6.95				
1434900—1953, D47, 48 (right*)	6.95				
1435468—1953, D44, 46 (right*)	6.95				
8 HOOD HINGE SPRING					
836783—195094				
1373067—1951-52	1.05				
1456771—1951, D44, 46	1.05				
9 HOOD PANEL HINGE					
STRAINER ASSY.					
1254614—1949	2.70				
9 HOOD PANEL INTERMEDIATE					
STRAINER					
1297520—1949-50	1.55				
9 HOOD PANEL HINGE					
STRAINER BRACE					
1244825—1949, D29 (right*) ..	.52				
1373193—1951-52, early63				
1435332—1951-52, late71				
1435409—1953, D44, 46	1.40				
1435200—1953, D47, 48	1.40				
1456958—1953, D47, 78 to					
cross bar	1.00				
9 HOOD FRONT STRAINER BRACE					
10 HOOD PANEL LOCK SUPPORT					
1240410—1949	2.95				
1335219—1950	2.95				
1347189—1951-52	1.90				
1435272—1953, D47, 48	2.95				
1435479—1953, D44	3.25				
1494045—1953, D46	2.45				
11 UPPER HALF HOOD LOCK					
1239994—1949	1.81				
1335222—1950	1.94				
1373261—1951-52	1.95				
1434906—Upper	1.95				
12 LOWER HALF HOOD LOCK					
1240225—1949	2.15				
1335712—1950, D33	2.15				
1347400—1951-52	2.15				
1434906—1953, up.	1.95				
1435203—1953, D47, 48, low. ...	2.15				
1456870—1953, D44, 46, low. ...	2.15				
13 HOOD LOCK LOWER SUPPORT					
1335476—1949-50	2.60				
1347195—1951	3.15				
1434853—1952	3.55				
1435272—1953, D47, 48, up. ...	2.95				
1435479—1953, D44, up.	3.25				
1494045—1953, D46, up.	2.45				
14 HOOD LOCK CONTROL KNOB					
AND WIRE					
1300622—1949-50	2.20				
14 HOOD LOCK CONTROL SUPPORT					
1301344—1949-5047				
15 RADIATOR GRILLE ASSY.					
1240653—1949	58.06				
1456827—1953, all, up. grille					
unit	8.75				
16 RADIATOR GRILLE NO. 1					
BAR EXTENSION					
1241150—1949 (right*)	2.54				
17 RADIATOR GRILLE TOP BAR					
1346824—1950 (right*)	6.20				
1456815—1953, top (right*) ...	6.75				
18 GRILLE CENTER UPPER BAR					
1335235—1950 (right*)	6.03				
19 GRILLE CENTER LOWER					
BAR					
1335237—1950 (right*)	6.03				
20 GRILLE BOTTOM BAR					
1346827—1950 (right*)	7.52				
1456825—1953, low. (right*) ..	5.40				
21 GRILLE MEDALLION					
1335300—1950	3.00				
22 GRILLE CENTER UNIT					
1335239—1950	10.75				
23 PARKING LAMP BEZEL					
1297833—1949	2.11				
1339788—1950	2.25				
1343758—1951-52	2.00				
23 PARKING LAMP LENS					
1297832—194972				
1339785—195072				
1343760—1951-5275				
1440340—1953, all	1.69				
23 PARKING LAMP LENS					
MOUNTING GASKET					
1297836—194911				
1339786—195040				
1343761—1951-5340				
23 PARKING LAMP HOUSING					
1297829—1949	1.69				
1339789—1950	2.60				
1343755—1951-52	2.60				
1343756—1953, all	2.48				
23 PARKING LAMP MOUNTING					
GASKET					
1297835—194922				
1339790—195022				
1343762—1951 to 5315				
23 PARKING AND DIRECTIONAL					
SIGNAL LAMP CABLE					
1244513—1949	2.94				
1343266—1950	1.58				
1345512—1951-52	1.47				
23 PARKING LAMP CABLE					
1343264—1950	1.15				
1384077—1951-52	1.15				
1495150—1953 (right)	1.25				
24 RADIATOR GRILLE UPPER					
UNIT					
1346723—1951-52	13.95				
1456827—1953, all	8.75				
25 GRILLE TOP BAR					
1346724—1951-52 (right*) ...	8.05				
1456815—1953 (right*)				
26 PARKING LAMP FRAME					
1346746—1951-52 (right*)	4.46				
1456832—1953 (right*)	3.95				
27 GRILLE VERTICAL BAR					
1366654—1951 (right*)	6.35				
1435034—195274				
1435022—1952	3.80				
1456828—195340				
28 RADIATOR GRILLE STONE					
DEFLECTOR LOWER OUTER					
MOLDING					
1346728—1951 (right*)	7.73				
1435517—1952 (right*)	2.15				

* Opposite side one part number higher

BODY PARTS 1949 thru 1953 DODGE ALL BODY STYLES

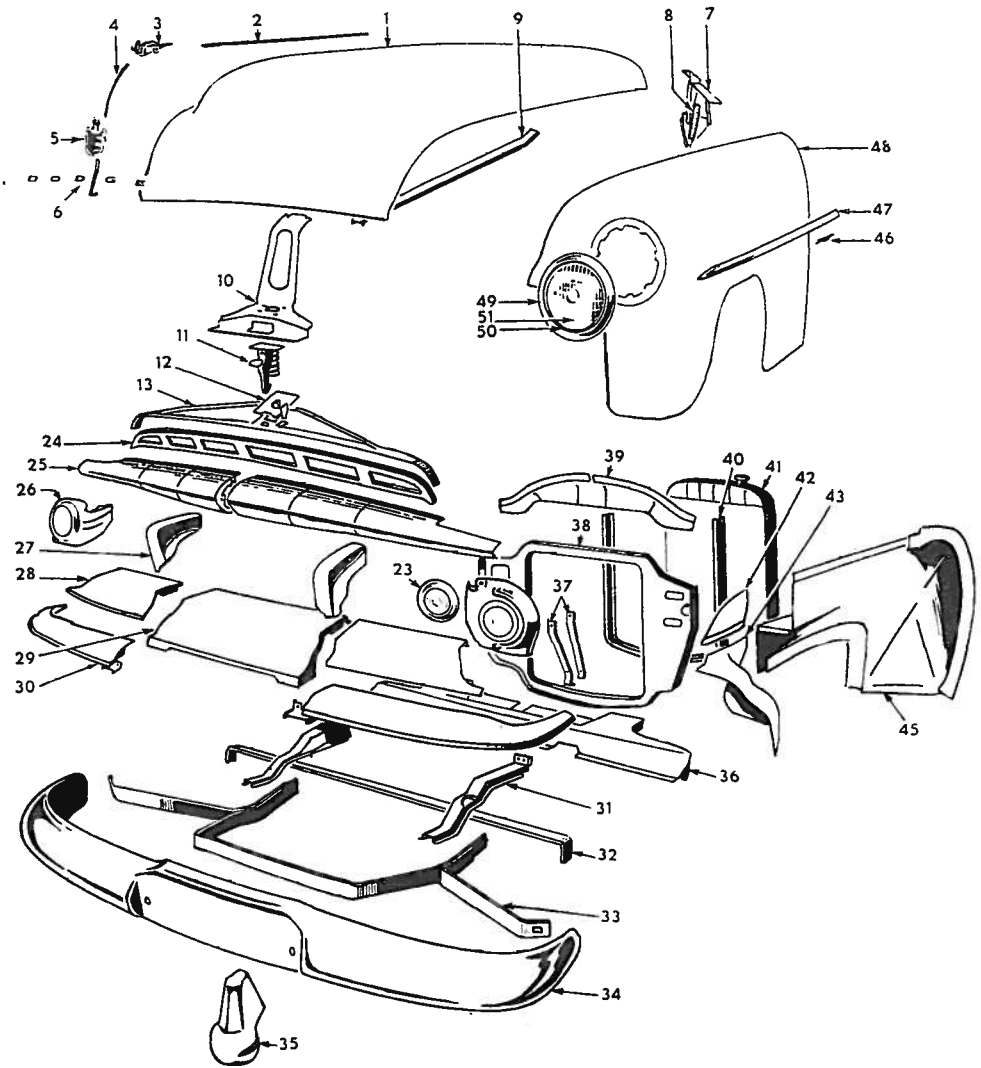
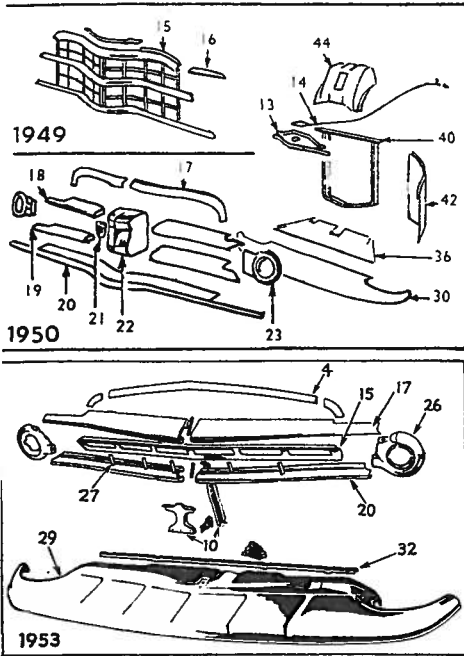

29 RADIATOR STONE DEFLECTOR	
1299539—1949, 7 sed.	7.84
1335984—1949-50, exc. 7 sed. and stn. wgn.	7.28
1335986—1950, 7 sed. and stn. wgn.	8.28
1347081—1951 (right*)	3.22
1434788—1952	8.60
1456874—1953, D46	8.60
1456972—1953, D47, 48	8.60
1456865—1953, D44	8.60
30 RADIATOR GRILLE STONE DEFLECTOR LOWER CENTER MOLDING	
1346722—1951	9.43
1435516—1952	2.20
31 RADIATOR YOKE TO STONE DEFLECTOR BRACE	
1347071—1951-52 (right*)	1.60
1456967—1953, D47, 4865
1456877—1953, D44, 4665
32 RADIATOR LOWER CROSS BAR	
1240486—1949	1.86
1335228—1950	1.86
1372968—1951-52	2.25
1456890—1953	2.35
33 FRONT BUMPER FACE BAR SUPPORT	
1137738—1949-50, exc. 7 sed., stn. and est. wgn.	12.09
1137842—1949-50, 7 sed. and stn. wgn.	12.85
1402912—1951-52 (right*)	4.73
1402912—1953, D44, 46 (right*)	4.73
1485300—1953, D47, 48 (right*)	5.75
34 FRONT BUMPER FACE BAR	
1137745—1949-50, exc. 7 sed., stn. and est. wgn.	39.11

1137839—1949-50, 7 sed. and stn. wgn.	40.65
1321720—1951-52	39.11
1329450—1953, D47, 48	32.95
1312720—1953, D44, 46	39.11
35 BUMPER BUFFER PLATE	
1141805—1949, exc. 7 sed. and stn. wgn. (right*)	7.85
1142189—1949-50, 7 sed., stn. and est. wgn. (right*)	6.88
1319585—1950, exc. 7 sed., stn. wgn. and spec. club cpe. (right*)	6.35
1324626—1951-53 (right*)	6.63
1483148—1953 (right*)	6.35
36 RADIATOR FRONT DUST SHIELD	
1335944—1949-50	3.85
1347075—1951-52	4.60

37 HOOD LOCK SUPPORT TO RADIATOR CROSS BAR BRACE	
1240568—194958
1335231—1950	1.28
37 HOOD LOWER LOCK SUPPORT TO RADIATOR SUPPORT BRACE	
1298956—1949-50	1.09
38 RADIATOR SUPPORT TO FENDER YOKE	
1373342—1951-52	5.41
1456967—1953, D47, 4865
1456877—1953, D44, 4665
39 RADIATOR YOKE TO HOOD AIR SHIELD SEAL	
1242974—1951-52 (ft.)37
1456691—1953, all45

Fig. 1—Front End of Car—1951-52—Illustrated Typical of 1953

* Opposite side one part number higher

continued

DODGE 1949 thru 1953 BODY PARTS

ALL BODY STYLES

Front End of Car —continued

40 RADIATOR SUPPORT	
1335846—1949	8.60
1335846—1950	8.60
1346649—1951-52	5.75
41 RADIATOR CORE	
1244436—1949, for high altitude	86.15
1346572—1949-50	65.88
1346558—1950, for high altitude	81.85
1373311—1951-52	70.95
1347097—1951-52, for high capacity	81.85
1494187—1953, D46	81.75
1456784—1953, D47	81.75
1494188—1953, D44	79.20
1494018—1953, D44, high capacity	85.85
1494189—1953, D48	79.20
42 RADIATOR UPPER SIDE SHIELD	
1244204—1949, w/seal (right*)	2.50
1335320—1950 (right*)	2.50
1346870—1951-52 (right*)94
43 RADIATOR LOWER SIDE SHIELD	
1240649—1949 (right)	1.48
1335297—1950 (right)	1.48
1335321—1950 (left)	3.42
1346876—1951-52 (right*)	2.15
44 RADIATOR UPPER SHIELD	
1240487—1949-50	4.20
45 FRONT FENDER UPPER RIGHT SHIELD	
1138420—1949-50	6.00
1325245—1951-52	6.00
1409179—1953, D47, up. (right*)	9.85
1484508—1953, D44 (right*) ..	12.75
1406736—1953, D46 (right*) ..	12.75
1409175—1953, D48 (right*) ..	12.75

45 FRONT FENDER LOWER RIGHT SHIELD	
1138413—1949-50	4.22
1325244—1951-52	4.22
1409174—1953, D47 (right) ...	5.45
45 FRONT FENDER LEFT SHIELD	
1326404—1949	12.75
1138412—1950	12.75
1325243—1951-52	12.75
46 FRONT FENDER SIDE NAME PLATE	
1300169—1949 to 52, 4 dr. sed. deluxe (Meadowbrook, F. D.)	1.98
1301386—1949-50 (Coronet, gyro-matic)	3.18
1301385—1949-50 (Coronet, fluid drive)	3.18
1347323—1951-52 (Coronet, fluid drive)	2.20
1347349—1951-52 (Coronet, gyro-matic)	2.22
1434648—1951-52 (Meadowbrook, gyro-matic)	2.65
1373365—1951-52, est. wgn. (Coronet-Sierra)	2.95
1456428—1953, D44, all, D48, exc. sub.	1.10
1456429—1953, D46, 47	1.10
1456616—1953, D48, spec. cpe..	1.45
47 FRONT FENDER SIDE MOLDING	
1256508—1949, D29 (right*) ..	3.67
1256512—1949, D30 (right*) ..	3.67
1335306—1950, D33, exc. roadster (right*)	4.08
1335282—1950, D33-34 and D33, roadster (right*)	4.08
1347335—1951-52, D41-42 (right*)	4.65
1435495—1953, D46, 47	1.85
1456608—1953, D47, 48	1.85
48 FRONT FENDER	
1240388—1949 (right*)	35.42
1335250—1950, exc. 7 sed. (right*)	38.85

1335290—1950, 7 sed. (right*) ..	30.44
1346585—1951-52, exc. 8 sed. (right*)	35.42
1373075—1951-52, 8 sed. (right*)	30.44
1494300—1953, D44, 46 (right*) ..	35.42
1494304—1953, D47, 48 (right*) ..	35.42
49 HEADLAMP DOOR	
1239411—1949-50	2.50
1345670—1951 to 53	3.95
50 SEALED BEAM UNIT RETAINING RING	
946942—1949 to 53	1.82
51 SEALED BEAM UNIT	
1297667—1949 to 53, bullseye lens	1.95
853369—1949-50, plain lens ...	1.65
52 HEADLAMP MOUNTING GASKET	
1310488—194921
1310488—1950 to 5321
HEADLAMP BULB MOUNTING SEAT	
946940—1949 to 53	1.78
HEADLAMP SHELL	
1154200—1949 to 53	3.26
HEADLAMP CABLE AND SOCKET	
1310740—1949	2.42
1340257—1950 to 52	2.59

Body Moldings

4-Door Sedans
See Fig. 2

1 HOOD TOP ORNAMENT	
1298935—1949-50	7.95
1 HOOD TOP ORNAMENT BASE	
1373215—1951	5.01
1456355—1952	7.65

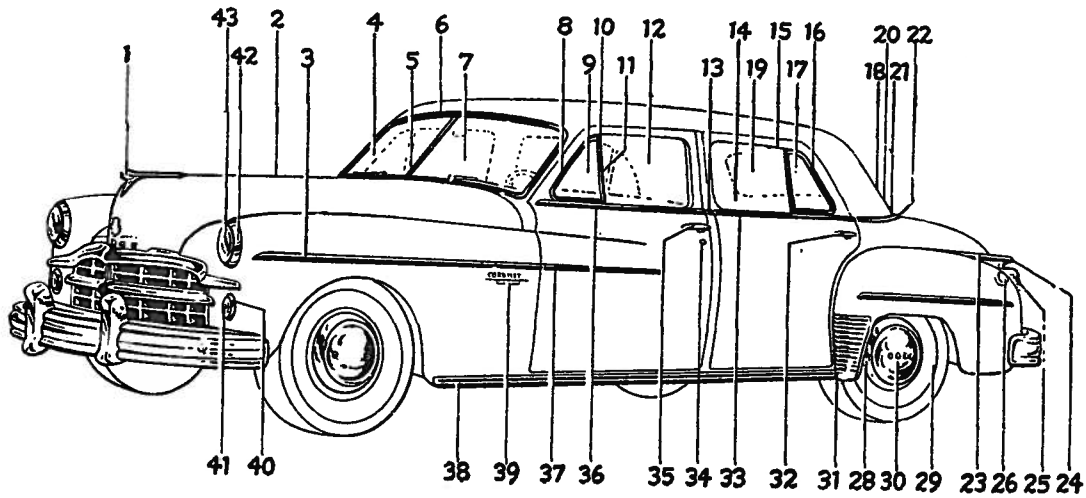

Fig. 2—Body Moldings—4-Door Sedans

* Opposite side one part number higher

BODY PARTS 1949 thru 1953 DODGE

ALL BODY STYLES

<p>1 HOOD TOP ORNAMENT HORN 1373213—1951-52 (right*) ... 3.75 1373283—1953 (right*) 3.75</p> <p>2 HOOD TOP MOLDING 1298954—1949-50 2.22 1347293—1951-52 2.10</p> <p>3 FRONT FENDER SIDE MOLDING 1256508—1949, D29 (right*).. 3.67 1256512—1949, D30 (right*).. 3.67 1335306—1950, D33, exc. roadster (right*) 4.08 1335282—1950, D33-34 and D33, roadster (right*) 4.08 1347335—1951-52, D41-42 (right*) 4.65 1435495—1953, D44, 46 (right*) 1.85 1456608—1953, D47, 48 (right*) 1.85</p> <p>4 WINDSHIELD OUTSIDE MOLDING 1256329—1949-50, D30-34 (right*) 3.89 1305134—1950, 7-8 pass. sed. (right*) 4.58 1298027—1950, stn. wgn. (right*) 3.89 1369554—1951-52, 4 dr. sed., carry-all sed. (upper right*) 2.47 1371378—1951-52, 4 dr. sed., carry-all sed., est. wgn. (lower right*) 2.10 1477568—1953, up. 1.85 1474823—1953 (right*) 1.85</p> <p>5 WINDSHIELD DIVISION BAR 1243904—1949 to 50, 4 dr. sed. 2.03 1296356—1949-50, stn. wgn. .. 2.46 1304960—1950, 7 pass. sed. 1371392—1951-52, 4 dr. sed., carry-all sed. 2.03 1381914—1951-52, 8 pass. sed. 2.13</p> <p>6 WINDSHIELD OUTER MOLDING, UPPER CLIP 1256331—1949-50, 4 dr. sed., 7 sed., stn. and est. wgn.38 1369539—1950 to 52, 4 dr. sed., est. wgn.27 1256331—1951-52, 8 pass. sed. .38 1474826—1953, cor. cap32</p> <p>7 WINDSHIELD GLASS 1243579—1949-50, 4 dr. sed.... P.O.A. 1255798—1949-50, stn. wgn.... P.O.A. 1304654—1950, 7 pass. sed. ... P.O.A. 1336096—1951-52, 4 dr. sed., sub. sed., est. wgn. P.O.A. 1305065—1951-52, 8 pass. sed., sub. sed. P.O.A. 1371984—1953 P.O.A.</p> <p>8 FRONT DOOR VENT WING GLASS FRAME 1301031—1949, stn. wgn. (right*) 5.78 1309134—1949 to 52, 4 dr. sed., carry-all sed., est. wgn. (right*) 4.41 1309102—1950, stn. wgn. (right*) 5.78 1338898—1950 to 52, 7-8 pass. sed., sub. sed. (right*) 1455362—1953 (right*) P.O.A.</p>	<p>9 FRONT DOOR VENT WING GLASS 1300143—1949, stn. wgn. P.O.A. 1302180—1949, 4 dr. sed. P.O.A. 1309138—1949 to 52, 4 dr. sed., carry-all sed., est. wgn. P.O.A. 1309108—1950, stn. wgn. P.O.A. 1304610—1950 to 52, 7-8 pass. sed. P.O.A. 1455364—1953 P.O.A.</p> <p>10 FRONT DOOR VENT WING WEATHERSTRIP RETAINER 1301035—1949 to 52, stn. wgn. (right*) 4.16 1308953—1949 to 52, 4 dr. sed. (right*) 4.16 1338902—1950, 7 pass. sed. (right*) 4.68 1385559—1951-52, 4 dr. sed., carry-all sed., est. wgn. (right*) 4.68 1348356—1951-52, 8 pass. sed., sub. sed. (right*) 4.68 1455200—1953 (right*) 1.95</p> <p>11 FRONT DOOR DIVISION CHANNEL INNER MOLDING 1296602—1949 to 52, 4 dr. sed., 7-8 pass. sed., stn. and est. wgn.63 1455369—195340</p> <p>11 FRONT DOOR DIVISION CHANNEL OUTER MOLDING 1296601—1949 to 52, 4 dr. sed., 7 pass. sed., stn. and est. wgn.68</p> <p>12 FRONT DOOR GLASS 1301007—1949 to 52, 4 dr. deluxe and custom N.P. 1241365—1949 to 52, 4 dr. custom special N.P. 1299496—1949-50, stn. wgn. .. N.P. 1301007—1950 to 52, carry-all sed., est. wgn. N.P. 1303821—1950 to 52, 7-8 pass. sed., sub. sed. N.P. 1372822—1953 N.P.</p> <p>13 CENTER PILLAR BELT MOLDING 1256169—1949 to 52, 4 dr. sed., carry-all sed., est. wgn.58 1305132—1950, 7-8 pass. sed., sub. sed.84</p> <p>14 REAR DOOR GLASS 1301008—1949, deluxe and custom N.P. 1240255—1949, custom special N.P. 1300253—1949-50, rear door, rear glass (stn. wgn.) N.P. 1308969—1950 to 52, 4 dr. sed., carry-all sed. N.P. 1304265—1950 to 52, 7-8 pass., sub. sed. N.P. 1300252—1950, rear door front glass (stn. wgn.) N.P. 1364005—1951 to 52, est. wgn. N.P. 1474538—1953 N.P.</p>	<p>15 REAR DOOR VENT WING WEATHERSTRIP RETAINER 1243380—1949-50, 4 dr. sed. (right*) 4.16 1332125—1950, est. wgn. (right*) 5.78 1385529—1951-52, carry-all sed. (left) 4.16 1385530—1951-52, 4 dr. sed., carry-all sed. (right*) 4.16 1385598—1951-52, est. wgn. (right*) 5.78 1385529—1951-52, carry-all sed. (left) 4.16 1385530—1951-52, 4 dr. sed., carry-all sed. (right*) 4.16 1385598—1951-52, est. wgn. (right*) 5.78 1455346—1953 (right*) 3.75</p> <p>16 REAR DOOR VENT WING GLASS FRAME 1509144—1949 to 52, 4 dr. sed. (right*) 4.26 1332140—1951 to 52, est. wgn. (right*) 5.20 1433312—1953 (right*) 3.00</p> <p>17 REAR DOOR VENT WING GLASS 1302181—1949 to 52, 4 dr. sed., carry-all sed. P.O.A. 1332136—1951-52, est. wgn. .. P.O.A. 1455397—1953 (right*) N.P.</p> <p>18 REAR WINDOW, OUTSIDE UPPER MOLDING 1256333—1949, 4 dr. sed. 3.57 1334898—1950, 4 dr. sed. (right*) 2.16 1305178—1950 to 52, 7-8 pass. sed. 7.20 1366342—1951-52, 4 dr. sed. .. 4.36</p> <p>19 REAR WINDOW GLASS 1240326—1949, 4 dr. sed. P.O.A. 1255122—1949, stn. wgn., upper tail gate P.O.A. 1333684—1950, 4 dr. sed. P.O.A. 1304486—1950, 7-8 pass. sed., sub. sed. P.O.A. 1366339—1951-52, 4 dr. sed., carry-all sed. P.O.A. 1364066—1951-52, est. wgn., tailgate (early) P.O.A. 1371867—1951-52, est. wgn., tailgate (late) P.O.A. 1372153—1953, 4 dr. sed. N.P.</p> <p>20 REAR WINDOW LOWER OUTSIDE MOLDING 1305179—1950 to 52, 7-8 pass. sed. 3.47</p> <p>22 REAR QUARTER BELT MOLDING 1256170—1949 to 52, 4 dr. sed., carry-all sed. (right*) 4.04 1305130—1950 to 52, 7-8 pass. sed. (right*) 4.46 1364557—1951-52, est. wgn. (right*) 3.68 1370967—1951-52, est. wgn., upper corner 1.94</p>
--	---	--

* Opposite side one part number higher

continued

DODGE 1949 thru 1953 BODY PARTS**ALL BODY STYLES****Body Moldings—continued**

1370968—1951-52, est. wgn., lower corner	1.94	1117383—1949-50, 4 dr. custom and custom special	4.05	37 FRONT DOOR FENDER EXTENSION MOLDING	
23 TAIL LAMP BASE		1117384—1949, 7 sed., stn. and est. wgn.	2.73	1252525—1949, 4 dr. sed. (right*)	1.69
1300547—1949, 4 dr. sed. (right*)	10.20	1324129—1951-52 4, dr. sed. deluxe	3.70	1333764—1950, 4 dr. sed., 7 pass. sed.	1.69
23 TAIL AND STOP LAMP BEZEL		1324130—1951-52, exc. 8 sed. and est. wgn.	4.05	1371300—1951-52, 4 dr. sed., 8 pass. sed., est. wgn. (right*)	2.37
1340351—1950 to 52, 4 dr. sed., 7 pass. sed. (early) (right*)	3.55	1324131—1951-52, 8 sed. and est. wgn.	3.25	38 BODY SIDE SILL MOLDING	
1436503—1951-52, 4 dr. sed. deluxe (late) (right*)	6.70	1487536—1953, D46, 47	2.95	1256002—1949, 4 dr. sed., stn. wgn. (right*)	10.34
1479202—1953	5.10	1487537—1953, D44, 48	3.63	1333987—1950, 4 dr. sed., use w/o fender shield (right*)	9.22
TAIL LAMP LENS RETAINER		31 REAR FENDER STONE SHIELD		1333994—1950, 4 dr. sed., stn. and est. wgn., use w/fender shield (right*)	10.07
1300553—1949, 4 dr. sed.89	1334353—1949, exc. 7 sed. and stn. wgn. (right*)	8.05	1341172—1950, 7 pass. sed. and limo. (right*)	13.42
TAIL LAMP LENS GASKET		1300257—1949-50, 7 sed. and stn. wgn. (right*)	8.47	1364852—1951-52, 4 dr. sed., est. wgn., early (right*) ...	11.03
1300927—1949, 4 dr. sed.28	1333975—1950, 4 dr. sed. (right*)	7.20	1364813—1951-52, 4 dr. sed., late (right*)	10.28
1340353—1950 to 52, 4 dr. sed., 7-8 pass. sed.45	1341154—1950, 7 sed. (right*) ..	8.74	1431514—1951-52, 8 pass. sed., early (right*)	14.91
1439893—195330	1364133—1950 to 53, est. wgn. (right*)	10.25	1432728—1951-52, 8 pass. sed., late (right*)	14.01
24 TAIL LAMP BUTTON REFLECTOR		1364523—1951-52, 4 dr. sed. (right*)	6.08	39 FRONT FENDER SIDE NAME PLATE	
1300840—1949, 4 dr. sed.74	1367700—1951-52, 8 sed. (right*)	12.10	1300169—1949 to 52, 4 dr. sed. deluxe (Meadowbrook, F. D.)	1.98
REFLECTOR EXTENSION ASSY.		1476087—1953, D44, 46 (right*) ..	4.65	1301386—1949-50 (Coronet, gyro-matic)	3.18
1300500—1950 to 5277	32 REAR DOOR OUTSIDE HANDLE		1301385—1949-50 (Coronet, fluid drive)	3.18
1253173—1951-5221	1243599—1949 to 52, 4 dr. sed., 7-8 pass. sed., est. wgn.	3.00	1347323—1951-52 (Coronet, fluid drive)	2.20
1235512—195321	1386081—1951-52, 4 dr. sed. ..	2.50	1347349—1951-52 (Coronet, gyro-matic)	2.22
25 TAIL LAMP LENS		1306464—1949 to 52, stn. wgn.	3.17	1434648—1951-52 (Meadowbrook, gyro-matic)	2.65
1300555—1949 (right*)	1.49	1433104—1953, all	2.80	1373365—1951-52, est. wgn. (Coronet-Sierra)	2.95
1340347—1950 to 52 (right*) ..	1.26	33 REAR DOOR BELT MOLDING		1456428—1953, Coronet	1.10
1439899—195360	1256167—1949 to 52, 4 dr. sed. (right*)	2.47	1456429—1953, Meadowbrook ..	1.10
26 FUEL TANK FILLER CAP		1304899—1950 to 52, 7-8 pass. sed.	3.21	40 PARKING LAMP BEZEL	
384982—1949 to 5280	1364439—1951-52, est. wgn. (right*)	2.57	1297833—1949	2.11
1404389—1953, chrome	1.45	34 DOOR LOCK CYLINDER AND KEYS PACKAGE		1339788—1950	2.25
26 FILLER TUBE FENDER HOLE COVER		1315510—1949 to 52, all mod.	2.21	1440340—1951-52	1.69
657625—1949 to 5247	1315521—1949, stn. wgn., tail gate lock	2.11	40 PARKING LAMP HOUSING	
27 REAR FENDER MOLDING		1316274—1950, stn. wgn.	2.21	1297829—1949	1.69
1252833—1949, exc. 7 sed., stn. wgn. (right*)	3.74	35 FRONT DOOR OUTSIDE HANDLE		1339789—1950	2.60
1253716—1949, 7 sed., stn. wgn. (right*)	12.90	1306470—1949, stn. wgn.	3.17	1343755—1951-52	2.60
1333837—1950, D33-34, exc. 2 dr. sed., stn. wgn.	4.11	1243597—1949 to 52, 4 dr. sed., early	3.00	1343756—1953	2.48
1340356—1950, D33-34, extension	4.52	1386079—1951-52, 4 dr. sed., late	2.52	40 PARKING LAMP MOUNTING GASKET	
1364970—1951-52, early (right*)	4.46	1372150—1951-52, 4 dr. sed., est. wgn., late	2.83	1297835—194922
1371997—1951-52, late (right*) ..	4.06	1433104—1953, all	2.80	1339790—195022
1476500—1953	5.50	36 FRONT DOOR BELT MOLDING		1343762—1951 to 5315
28 WHEEL ASSY.		1256165—1949, 4 dr. sed. (right*)	2.47	40 PARKING LAMP LENS MOUNTING GASKET	
1136619—1949 to 52, 7-8 sed. and stn. wgn. (15x6.00) ...	12.85	1305128—1950 to 52, 7-8 sed. and limo., sub. sed. (right*) ..	3.47	1297836—194911
1270660—1949 to 53, exc. 7-8 sed. and est. wgn. (15x5.00) ..	13.50	1369508—1951-52, 4 dr. sed., carry-all sed., est. wgn. (right*)	2.47	1339786—195040
1316710—1949 to 53 (15x4.50) .	10.60	37 FRONT DOOR BELT MOLDING		1343761—1951 to 5340
29 WHEEL COVER (Exc. 4 dr. deluxe)		1256165—1949, 4 dr. sed. (right*)	2.47	41 PARKING LAMP LENS	
1321596—1949-50	8.25	1305128—1950 to 52, 7-8 sed. and limo., sub. sed. (right*) ..	3.47	1297832—194972
1324550—1951-52	8.24	1369508—1951-52, 4 dr. sed., carry-all sed., est. wgn. (right*)	2.47	1339785—195072
1488431—1953, D44, 48	8.24	38 FRONT DOOR BELT MOLDING		1343760—1951-5275
30 WHEEL HUB CAP		1256165—1949, 4 dr. sed. (right*)	2.47	1440340—1953	1.69
1117382—1949-50, 4 dr. sed. deluxe	3.70	39 FRONT DOOR BELT MOLDING			

* Opposite side one part number higher

BODY PARTS 1949 thru 1953 DODGE

ALL BODY STYLES

42 HEAD LAMP DOOR	
1239411—1949-50	2.50
1345670—1951 to 53	3.95
42 SEALED BEAM UNIT RE-TAINING RING	
946942—1949 to 53	1.82
43 SEALED BEAM UNIT	
1297667—1949 to 52, bulls eye lens	1.95
853369—1949-50, plain lens ...	1.65
43 HEADLAMP BULB MOUNTING SEAT	
946940—1949 to 53	1.78
43 HEADLAMP SHELL	
1154200—1949 to 53	3.26
43 HEADLAMP MOUNTING GASKET	
1310488—1949 to 5321
43 HEADLAMP CABLE AND SOCKET	
1310740—1949 (right*)	2.42
1340257—1950 to 53	2.59

Body Sheet Metal and Fuel Tank

4-Door Sedans and Station Wagon
Models D30-54-42

See Fig. 3

1 COWL SIDE PANEL	
1240722—1949-50 (right*) ...	20.45
1385126—1951-52 (right*) ...	12.35
1528068—1953, 4 dr. sed. (right*)	16.20
1458886—1953, sta. wgn. (right*)	15.75

2 DASH PANEL ASSEMBLY	
1244135—1949	11.00
1336361—1950, exc. est. wgn..	11.00
1371148—1951-52	11.00
1528111—1953, D44, 46	11.00
1528159—1953, D47, sta. wgn..	21.28
1528165—1953, D48, all	15.25

3 FRONT DOOR ASSEMBLY (Less Glass, Trim and Hardware)	
1334823—1949-50, 4 dr. sed., sta. and est. wag. (right*)..	54.77
1371599—1951-52, 4 dr. carry-all sed., est. wag. (right*)..	54.77
1528237—1953, 4 dr. sed. (right*)	56.75

3 FRONT DOOR REPAIR PANEL	
1333036—1949, 4 dr. sed. (right*)	12.23
1334825—1950, 4 dr. sed. (right*)	12.23
1371643—1951-52, 4 dr. sed., carryall sed., est. wag. (right*)	12.23
1299398—1949-50, sta. wag. (Honduras) (upper right*)..	11.30
1299396—1949-50, sta. wag. (vermilion) (upper right*)..	11.30
1299402—1949-50, sta. wag. (vermilion) (lower right*)..	19.34
1299404—1949-50, sta. wag. (Honduras) (lower right*)..	19.34
1476831—1953, 4 dr., front	13.25
1476835—1953, 4 dr., rear	13.25
1476839—1953, 2 dr., cl. cpe....	15.25
1432472—1953, cv. cpe., sp. cl. cpe.	13.75
1525872—1953, Suburban	13.30

4 BODY CENTER PILLAR	
1243915—1949 to 52, 4 dr. sed. (right*)	11.61

1255924—1949, sta. wag. (right*)	41.42
1255888—1950, sta. wag. (right*)	41.42
1243915—1951-52, carryall sed., est. wag. (right*)	11.61
1528098—1953, 4 dr. sed. (right*)	14.50

5 BODY SIDE SILL INNER PANEL	
1240643—1949 to 52, 4 dr. sed., stn. and est. wag., carryall sed. (right*)	5.26
1528020—1953, 4 dr. sed. (right*)	5.25

5 BODY SIDE SILL OUTER PANEL	
1240641—1950, 4 dr. sed. (right*)	6.88
1298773—1949-50, sta. wag. (right*)	9.41
1334906—1951-52, 4 dr. sed., carryall sed., est. wag. (right*)	6.74
1528194—1953, 4 dr.	7.10
1528172—1953, 2 dr. cl. cpe.	7.10
1458678—1953, sp. cl. cpe.	6.10

6 REAR SIDE QUARTER PANEL	
1239061—1949, 4 dr. sed. (right*)	55.77
1340809—1950, 4 dr. sed. (right*)	55.77
1344962—1950, sta. wag. (Honduras) (right*)	298.02
1344693—1951-52, 4 dr. sed., carryall sed. (right*)	54.57
1384142—1951-52, est. wag. (early) (right*)	103.55
1438462—1951-52, est. wag. (late) (right*)	107.49
1496784—1953, sub. (right*) ..	114.00

continued

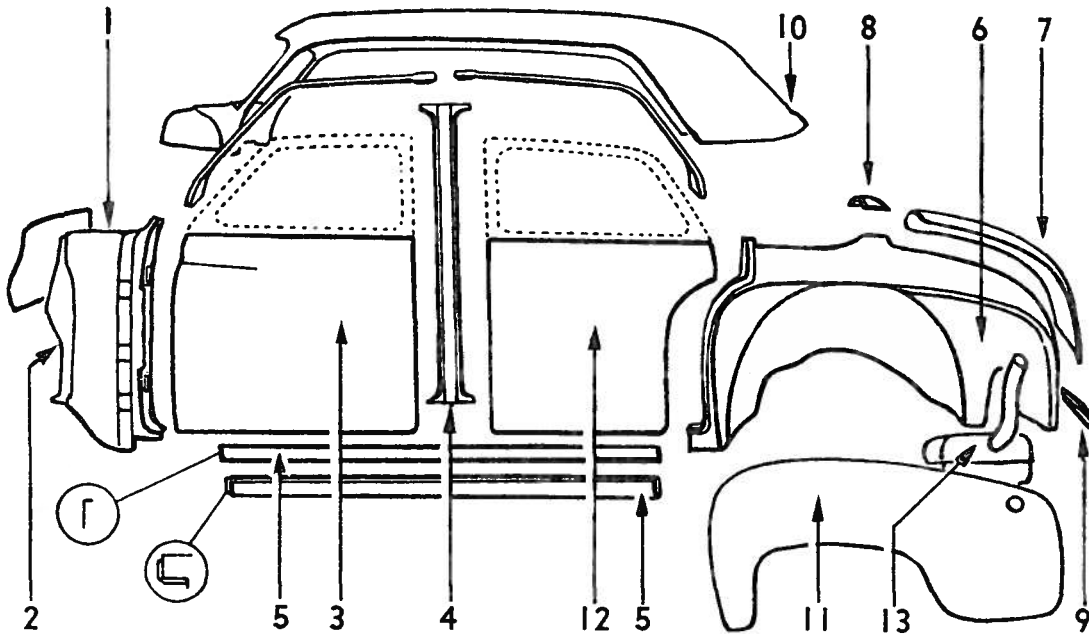

Fig. 3—Body Sheet Metal

* Opposite side one part number higher

DODGE 1949 thru 1953 BODY PARTS

ALL BODY STYLES

Body Sheet Metal and Fuel Tank—continued

7 LUGGAGE COMPARTMENT LID	
1333724—1949, 4 dr. sed.....	40.31
1331856—1950, 4 dr. sed.....	40.31
1331856—1951-52, 4 dr. sed....	40.31
1528033—1953, 4 dr., exc. D48.	43.00
1527998—1953, 4 dr., D48	42.25
8 LUGGAGE COMPARTMENT OPENING UPPER PANEL	
1239065—1949, 4 dr. sed.....	5.78
1242739—1950, 4 dr. sed.....	5.78
1384168—1951-52, 4 dr. sed....	5.78
1432916—1953, 4 dr. sed.	9.85
9 LUGGAGE COMPARTMENT OPENING LOWER PANEL	
1241331—1949 to 52, 4 dr. sed.	3.89
1528028—1953, 4 dr. sed.	10.75
10 ROOF PANEL ASSEMBLY	
1239032—1949, 4 dr. sed.....	129.71
1340827—1950, 4 dr. sed.....	129.71
1435602—1951-52, 4 dr. sed...	126.93
1528043—1953, 4 dr. sed.	129.70
ROOF REPAIR PANEL	
1308756—1950, 4 dr. sed.....	37.00
11 REAR FENDER	
1252777—1949, exc. 7 sed., sta. wag.	19.48
1244442—1949, 7 sed., sta. wag.	19.16
1333878—1950, exc. 7 sed., sta. and est. wag. (right*)	19.48
1334324—1950, 7 sed. (right*)	19.16
1333485—1950, sta. wag. (right*)	21.69
1364166—1950 to 52, est. wag. (right*)	21.69
1372061—1951-52 (right*)	19.48
1371271—1951-52, 8 sed. (right*)	21.69
REAR FENDER BRACE	
1243997—1949 (right*)47
1334348—1950 to 52, exc. 7-8 sed. and est. wag. (right*)52
1299434—1950, sta. wag. (right*)47
1342654—1951-52, 8 sed. and limo. (right*)58
12 REAR DOOR ASSEMBLY (Less Glass, Trim and Hardware)	
1338202—1950, 7 sed. (right*)	69.43
1337564—1950, sta. wag., vermilion panels (right*)	227.76
1337566—1950, sta. wag., Honduras panels (right*)	227.76
1371603—1949 to 52, 4 dr. sed. (right*)	54.77
1368408—1951-52, 8 sed. and limo. (right*)	64.93
1371607—1951-52, est. wag. (right*)	54.77
1528239—1953, 4 dr. sed. (right*)	56.75
12 REAR DOOR REPAIR PANEL	
1309339—1950 to 52, 4 dr. sed. (right*)	12.23

1341418—1950 to 52, 7-8 sed., sub. sed. (right*)	13.40
1299408—1950, sta. wag., upper, vermilion (right*)	P.O.A.
1299414—1950, sta. wag., lower, vermilion (right*)	P.O.A.
1299410—1950, sta. wag., upper, Honduras (right*)	10.78
1299416—1950, sta. wag., lower, Honduras (right*)	11.88
13 FUEL TANK	
1138587—1949 to 52, all exc. sta. and est. wag.	16.25
1311996—1949, sta. wag.	21.55
1314776—1950 to 52, sta. and est. wag.	27.95
1483601—1953, 4 dr. sed. and est. wag.	16.25
FUEL TANK SUPPORT STRAP	
1126688—1949 to 52, all exc. sta. wag. and est. wag.75
1311993—1949, sta. wag.68
1314736—1950, sta. and est. wag. (right*)79
1405112—1953 (right*)	1.45

1371627—1951-52, 3 cpe. (right*)	58.17
1371599—1951-52, 4 dr. sed., carry-all sed., est. wgn. (right*)	54.77
1371619—1951-52, club cpe. (right*)	58.17
1380956—1951-52, 8 sed. and limo. (right*)	64.93
1298148—1953, all	2.39

1 DOOR ASSY. (Includes hardware, trim and glass)	
1316171—1949, 4 dr. sed. (right*)	154.10
1365055—1950, 2 dr. sed. (right*)	154.10
1365053—1950 3 cpe. (right*)	154.10
1365061—1950, 4 dr. sed. (right*)	154.10
1365059—1950, club cpe. (right*)	160.52
1386033—1951-52, 2 dr. sed. (right*)	154.10
1386035—1951-52, 3 cpe. (right*)	154.10
1386039—1951-52, 4 dr. sed. (right*)	154.10
1386045—1951-52, club cpe. (right*)	160.52
1386043—1951-52, conv. cpe., spec. club cpe. (right*)	212.47
1386120—1951-52, 8 pass. sed. (right*)	160.52
1386049—1951-52, est. wgn. (right*)	135.77

2 DOOR UPPER HINGE	
1244180—1949, D39-30, all exc. stn. wgn. (right*)	4.77
1299947—1949, D30, stn. wgn. (right*)	5.26
1333271—1950, D33-34, exc. stn. wgn. (right*)	4.77
1333355—1950, D34, stn. wgn. (right*)	5.26
1334983—1951-52, D41-42 (right*)	4.75
1457912—1953, D47, 48 (right*)	2.65
1475834—1953, D44, 46 (right*)	2.95

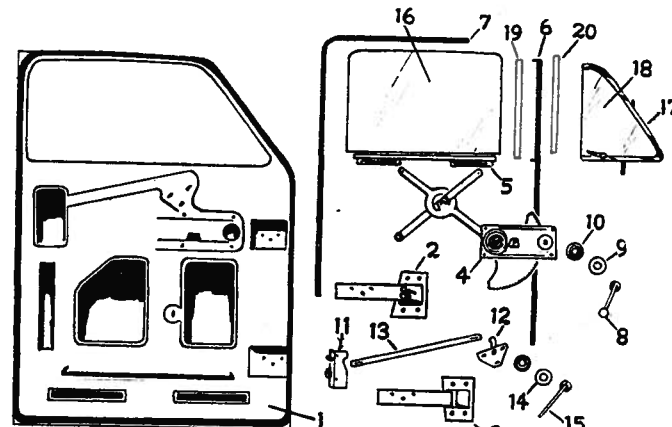

Fig. 4—Front Door Assembly

* Opposite side one part number higher

BODY PARTS 1949 thru 1953 DODGE

ALL BODY STYLES

DOOR LOWER HINGE

1244187—1949, D29-30, all exc. stn. wgn. (right*)	3.76
1299951—1949, D30, stn. wgn. (right*)	4.34
1307509—1950, D33-34, exc. stn. wgn. (right*)	4.02
1299951—1950, D34, stn. wgn. (right*)	4.84
1334985—1951-52, D41-42 (right*)	4.02
1491054—1953, D47, 48 (right*)	2.65
1475826—1953, D47, 48 (right*)	2.95

WINDOW REGULATOR

1296547—1949, 2 dr. sed., 3 cpe., club cpe. (right*)	5.74
1242639—1949 to 52, 4 dr. sed. (right*)	5.36
1257176—1949-50, stn. wgn. (right*)	5.88
1242639—1950, 4 dr. sed. (right*)	5.36
1470076—1953, 2 dr., cl. cpe. (right*)	5.74
1457206—1953, conv., spec. cpe. (right*)	6.75

PLATE AND ARM

1249650—1950 to 52, conv. cpe., roadster, spec. club cpe. (right*)	6.75
1296547—1950 to 52, 2 dr. sed., 3 cpe., club cpe. (right*)	5.74
1305290—1950 to 52, 7-8 pass. sed. (right*)	5.25
1528237—1953, 4 dr. (right*)	56.75
1528241—1953, 2 dr. cl. cpe. (right*)	60.50
1431320—1953, conv. spec. cl. cpe. (right*)	61.75

DOOR WINDOW FRAME**LOWER CHANNEL**

1308763—1949, roadster	5.46
1243812—1949 to 52, 4 dr. sed. (right*)	1.10
1242281—1949 to 52, 2 dr. sed. (right*)	2.16
1243946—1949 to 52, 3 cpe., club cpe. (right*)	2.16
1246834—1949-50, conv. cpe., spec. club cpe. (right*)	4.16
1254847—1949-50, stn. wgn. (right*)	1.10
1303816—1949 to 52, 7-8 pass. sed. (right*)	1.32
1332295—1950, roadster (right*)	4.68
1380200—1951-52, conv. cpe., roadster, spec. club cpe. (right*)	4.36
1475035—1953, 4 dr. sed. (right*)	1.00
1470096—1953, 2 dr., 3 cpe., cl. cpe. (right*)	1.42
1458104—1953, conv., spec. cpe. (right*)	3.95

FRONT DOOR GLASS DIVISION CHANNEL RUN

1243578—1949 to 52, 2 and 4 dr. sed., 3 cpe., club cpe.	1.27
---	------

1246909—1949, conv. cpe., spec. club cpe.	1.15
1301044—1949-50, stn. wgn.	1.21
1304620—1949 to 52, 7-8 pass. sed., sub. sed.	1.27
1380360—1951-52, conv. cpe., roadster, spec. club cpe.	1.23
1455370—1953, 2 & 4 dr., 3 cpe., cl. cpe.	1.27
1459534—1953, conv.	1.35
1459570—1953, spec. cpe.	1.35
1433334—1953, sub.	1.21

7 FRONT DOOR GLASS RUN

1244047—1949 to 52, 3 cpe., club cpe. (right*)	2.10
1242309—1949 to 52, 2 dr. sed.	2.10
1299959—1949-50, stn. wgn., upper	1.10
1243575—1949 to 52, 4 dr. sed., carry-all sed. (right*)	1.94
1338780—1949, conv. cpe., rear	.42
1338780—1952, conv. cpe., roadster, spec. club cpe.	.42
1305518—1950, 7-8 pass. sed.	1.37
1490525—1953, 4 dr. sed. (right*)	1.94
1470034—1953, 2 dr., 3 cpe., cl. cpe. (right*)	2.20
1457769—1953, conv., spec. cpe. (right*)	.42
1432826—1953, sub.	2.80

8 DOOR WINDOW REGULATOR HANDLE

1296581—1949-50, 4 dr. sed.	1.84
1296582—1949-50, D30-34C	1.84
1298148—1949 to 52, D29-33-41-42; 1953, all	2.39

9 WINDOW REGULATOR HANDLE ESCUTCHEON

1296570—1949-50, D30-34C	.74
1256038—1949 to 52, D30-33-34S-41-42	.37
1298661—1951-52, D41	.42
1300153—1951-52, D41-42	.84
1256038—1953, all	.37

10 REGULATOR HANDLE ESCUTCHEON SPRING

89796—1949 to 53	.06
------------------	-----

11 FRONT DOOR LOCK

1242693—1949 to 52 (right*)	3.80
1255057—1949-50, stn. wgn. (right*)	3.68
1432646—1953, exc. conv., spec. cpe. (right*)	3.80
1458152—1953, conv., spec. cpe. (right*)	3.80
1474888—1953, D44, 46, 4 dr. (right*)	3.80

12 DOOR LOCK REMOTE CONTROL

1296698—1949 to 52, exc. 7-8 pass. sed., stn. wgn. (right*)	1.21
1257171—1949-50, stn. wgn. (right*)	1.42
1304566—1950 to 52, 7-8 pass. sed. (right*)	1.21
1475112—1953, 2 & 4 dr., cl. cpe., 3 cpe. (right*)	1.21

1432778—1953, conv., spec. cpe., sub. (right*)	1.10
--	------

13 REMOTE CONTROL LINK

1244139—1949 to 52, 2 dr. sed., 3 cpe., club cpe., roadster	.74
1257170—1949-50, stn. wgn., est. wgn.	.63
1244137—1949 to 52, 4 dr. sed., carry-all sed., est. wgn.	.47
1304694—1950 to 52, 7-8 pass. sed. (right*)	.68
1372773—1953, 4 dr. sed.	.47
1470052—1953, 2 dr., 3 cpe., cl. cpe.	.68
1457696—1953, conv., spec. cpe. (right*)	.68
1432788—1953, sub.	.68

14 REMOTE CONTROL HANDLE ESCUTCHEON

1300152—1949-50, 4 dr. sed., club cpe., conv. cpe., spec. club cpe.	1.10
1300153—1949 to 52, 4 dr. sed., club cpe., conv. cpe.	.84
1298661—1949 to 53, 2 dr. sed., 3 cpe., roadster	.42
1256038—1953, exc. 2 dr. sed.	.37

15 REMOTE CONTROL HANDLE

981381—1949 to 52, all exc. est. wgn.; 1953, D44, 46	1.10
987067—1953, D47, 48	1.31

16 DOOR GLASS

1302226—1949, 2 dr. sed., 3 cpe., club cpe.	P.O.A.
1301007—1949 to 52, 4 dr. sed. (deluxe and custom)	P.O.A.
1241365—1949-50, 4 dr. sed. (custom special)	P.O.A.
1246836—1949, conv. cpe.	P.O.A.
1299496—1949, stn. wgn.	P.O.A.
1308760—1949, roadster (plastic)	16.29
1242270—1950 to 52, 2 dr. sed.	P.O.A.
1302226—1950 to 52, 3 cpe., club cpe.	P.O.A.
1336553—1950, conv. cpe., spec. club cpe.	P.O.A.
1303821—1950 to 52, 7-8 pass. sed., carry-all sed.	P.O.A.
1299496—1950, stn. wgn.	P.O.A.
1373930—1951-52, roadster	P.O.A.
1381298—1951-52, conv. cpe., spec. club cpe.	P.O.A.
1372822—1953, 4 dr. sed.	P.O.A.
1432544—1953, sub.	P.O.A.
1470003—1953, 2 dr., 3 cpe., cl. cpe.	P.O.A.
1433359—1953, conv.	P.O.A.
1433358—1953, spec. cpe.	P.O.A.

17 DOOR VENT. WING GLASS FRAME

1309134—1949, 4 dr. sed., club cpe. (right*)	4.41
1242321—1949, 2 dr. sed. (right*)	3.16
1309113—1949, 3 cpe. (right*)	3.16
1301031—1949, stn. wgn. (right*)	5.78

continued

* Opposite side one part number higher

DODGE 1949 thru 1953 BODY PARTS

ALL BODY STYLES

Front Door—continued

1342476—1949, conv. cpe. (right*)	9.41
1497020—1953, 4 dr., cl. cpe., sub. (right*)	4.15
1455362—1953, 2 dr. (right*)
1477704—1953, conv. (right*) ..	5.05
1477706—1953, spec. cpe. (right*)	5.05

18 DOOR VENT. WING GLASS

1242310—1949, 2 dr. sed.	P.O.A.
1300143—1949, stn. wgn.	P.O.A.
1302180—1949, 4 dr. sed., 3 cpe., club cpe.	P.O.A.
1246981—1949, conv. cpe.	P.O.A.
1306599—1950 to 52, 2 dr. sed.	P.O.A.
1309138—1950 to 52, 4 dr. sed., 3 cpe., club cpe.	P.O.A.
1342480—1950 to 52, conv. cpe., spec. club cpe.	P.O.A.
1309108—1950, stn. wgn., est. wgn.	P.O.A.
1304610—1950 to 52, 7-8 sed. and limo.	P.O.A.
1309138—1951-52, carry-all sed., est. wgn.	P.O.A.
1380490—1951-52, roadster ...	P.O.A.
1455364—1953, 2 & 4 dr., 3 cpe., cl. cpe.	P.O.A.
1432837—1953, sub.	P.O.A.
1457272—1953, conv.	P.O.A.
1457273—1953, spec. cpe.	P.O.A.

**19 FRONT DOOR DIVISION CHAN-
NEL INNER MOLDING**

1242425—1949, white, 2 dr. sed.	.68
1296602—1949 to 52, 4 dr. sed., 3 cpe., club cpe., 7-8 sed., stn. wgn.68
1380364—1951-52, conv. cpe., roadster, spec. club cpe.68
1455369—1953, 2 & 4 dr., 3 cpe., cl. cpe.40
1459425—1953, conv.40
1459087—1953, spec. cpe.40
1433315—1953, sub., est. wgn..	.40

**20 FRONT DOOR DIVISION CHAN-
NEL OUTER MOLDING**

1242426—1949, white, 2 dr. sed.	.63
1296601—1949 to 52, 4 dr. sed., 3 cpe., club cpe., 7-8 sed., stn. wgn.63
1380365—1951-52, conv. cpe., roadster, spec. club cpe.63
1459262—1953, conv.35
1459456—1953, spec. cpe.35
1433314—1953, sub., est. wgn...	.35

Rear Door

*4-Door Sedan and Station Wagon
Models 30-34-42*

See Fig. 5

**1 REAR DOOR (Less Glass, Trim and
Hardware)**

1338202—1950, 7 pass. sed. (right*)	69.43
1337564—1950, sta. wag., ver- million panels (right*)	227.76
1337566—1950, sta. wag., Hon- duras panels (right*)	227.76
1371603—1949 to 52, 4 dr. sed., carryall sed. (right*)	54.77
1368408—1951-52, 8 pass. sed. (right*)	64.93
1371607—1951-52, est. wag. (right*)	54.77
1528239—1953, 4 dr. sed. (right*)	56.75

**REAR DOOR (Includes Hardware,
Trim and Glass)**

1316173—1949, 4 dr. sed. (right*)	154.10
1365064—1950, 4 dr. sed. (right*)	154.10
1386041—1951-52, 4 dr. sed. (right*)	154.10
1386122—1951-52, 8 pass. sed. (right*)	148.84
1386051—1951-52, est. wag. (right*)	135.77

2 UPPER DOOR HINGE

1307512—1949 to 52, 4 dr. sed., carryall sed., est. wag. (right*)	3.11
1256056—1949-50, body half, sta. wag. (right*)	3.37
1256054—1949-50, door half, sta. wag. (right*)	3.37
1305284—1950, 7 pass. sed. (right*)	3.37
1304628—1951-52, 8 pass. sed. (right*)	3.37
1372615—1953, D44, 46 (right*)	2.95
1457912—1953, D47, 48 (right*)	2.65

3 LOWER DOOR HINGE

1307515—1949 to 52, 4 dr. sed., est. wag., carryall sed. (right*)	3.11
1256062—1949-50, sta. wag., body half (right*)	3.37
1256060—1949-50, sta. wag., door half (right*)	3.37
1304580—1950 to 52, 7-8 pass. sed. (right*)	3.11
1491062—1953, D47, 48 (right*)	2.65
1372621—1953, D44, 46 (right*)	2.95

4 DOOR WINDOW REGULATOR

1243478—1949 to 52, 4 dr. sed., est. wag., carryall sed. (right*)	6.47
1304780—1950 to 52, 7-8 pass. sed. (right*)	6.88
1474871—1953, 4 dr. sed. (right*)	6.47

5 DOOR GLASS REAR RUN

1243407—1949 to 52, 4 dr. sed., est. wag., carryall sed. (right*)	1.94
1299957—1949 to 52 (top and bottom), sta. wag. (right*)	1.37
1305496—1950 to 52, 7-8 pass. sed.	2.37
1334493—1950, glass bottom run, sta. wag.	1.37
1299958—1950, glass rear run, sta. wag.84
1490526—1953, 4 dr. sed.	2.10

**6 DOOR GLASS DIVISION CHANNEL
RUN**

1243401—1949 to 52, 4 dr. sed.	1.27
1332148—1950 to 52, est. wag.	1.27
1455370—1953, 4 dr. sed.	1.27

7 DOOR GLASS LOWER CHANNEL

1243821—1949, 4 dr. sed. (right*)	1.10
1307885—1950 to 52, 4 dr. sed., est. wag., carryall sed. (right*)	1.10
1304260—1950-52, 7-8 sed. (right*)	1.69
1475048—1953, 4 dr. sed. (right*)	1.10

8 REGULATOR HANDLE

1296582—1949, 4 dr. custom..	1.84
1296581—1949 to 52, 4 dr. de- luxe	1.84
1296582—1950	1.84
1298148—1953	2.39

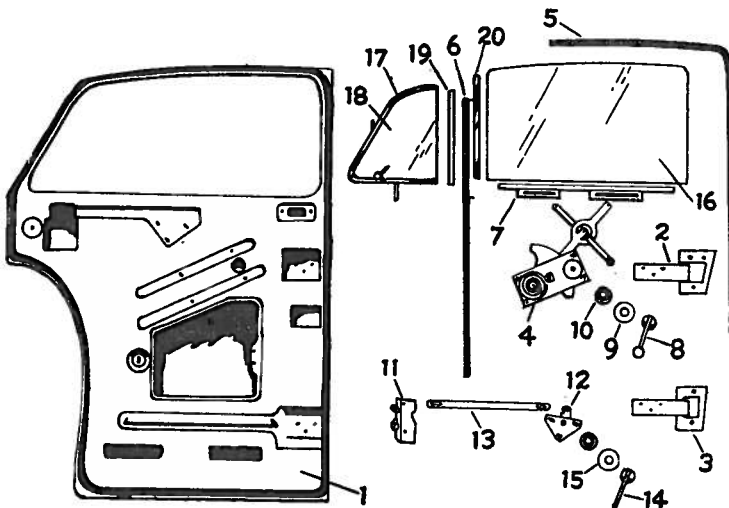

Fig. 5—Rear Door—4-Door Sedans

* Opposite side one part number higher

BODY PARTS 1949 thru 1953 DODGE ALL BODY STYLES

9 REGULATOR HANDLE ESCUTCHEON	
1256038—1949 to 52, 4 dr. deluxe37
1296570—1949-50, 4 dr. custom74
1256038—1953, 4 dr. sed.37
10 REGULATOR HANDLE ESCUTCHEON SPRING	
89796—1949 to 5306
11 REAR DOOR LOCK	
1243300—1949 to 52 (right*)..	3.80
1305266—1950 to 52, 7-8 pass. sed. (right*)	4.82
1474886—1953, 4 dr. sed. (right*)	3.80
12 DOOR LOCK REMOTE CONTROL	
1244247—1949 to 52 (right*)..	1.15
1256254—1949, sta. wag. (right*)	1.42
1304950—1951-52, 7-8 pass. sed. (right*)	1.21
1475259—1953, 4 dr. sed. (right*)	1.15
13 LOCK REMOTE CONTROL LINK	
1244136—1949, 4 dr. sed.....	.42
1304954—1950 to 52, 7-8 pass. sed. (right*)42
14 DOOR REMOTE CONTROL HANDLE	
981381—1949 to 53	1.10
15 REMOTE CONTROL HANDLE ESCUTCHEON	
1300152—1949-50, 4 dr. sed... ..	1.10
1300153—1949 to 52, 4 dr. sed., 7-8 sed.84
1256038—1953, 4 dr. sed.37
16 DOOR GLASS	
1301008—1949, 4 dr. deluxe and custom	P.O.A.
1240255—1949, 4 dr. custom special	P.O.A.
1308969—1950 to 52, 4 dr. and carryall sed.	P.O.A.

1304265—1950 to 52, 7-8 pass. sed.	P.O.A.
1300252—1950, rear door front, sta. wag.	P.O.A.
1300253—1950, rear door rear, sta. wag.	P.O.A.
1364005—1951-52, est. wag....	P.O.A.
1474538—1953, 4 dr. sed.
17 REAR DOOR VENT WING GLASS FRAME	
1309144—1949 to 52, 4 dr. sed., carryall sed. (right*).....	4.26
1332140—1951-52, est. wag. (right*)	5.20
1433800—1953, 4 dr. (right*)..	3.30
18 DOOR VENT WING GLASS	
1302181—1949 to 52, 4 dr. sed., carryall sed.	P.O.A.
1455397—1953, 4 dr. sed.	P.O.A.
19 DOOR DIVISION CHANNEL INNER MOLDING	
1296602—1949, 4 dr. sed.68
1296601—1950 to 52, 4 dr. sed., sub. sed.63
1309470—1950, sta. wag., sliding glass molding.....	.84
1332152—1950 to 52, est. wag.63
1455369—1953, in. & out.40
20 DOOR DIVISION CHANNEL OUTER MOLDING	
1296601—1949, 4 dr. sed.....	.63
1296602—1950 to 52, 4 dr. sed.; sub. sed.68
1332150—1950 to 52, est. wag.68

SEE ITEM NO. 19

Body Moldings

2-Door Sedan and Coupes
See Fig. 6

1 HOOD TOP ORNAMENT	
1298935—1949-50	7.95
1 HOOD TOP ORNAMENT BASE	
1373215—1951	5.01

1456355—1952	7.95
1456250—195350
1 HOOD TOP ORNAMENT HORN	
1373213—1951-52 (right*)	2.35
1373283—1953 (right*)
2 HOOD TOP MOLDING	
1298954—1949-50	2.22
1347293—1951-52	2.10
3 FRONT FENDER SIDE MOLDING	
1256508—1949, D29 (right*)..	3.67
1256512—1949, D30 (right*)..	3.67
1335306—1950, D33 exc. roadster (right*)	4.08
1335282—1950, D33-34 and D33 roadster (right*)	4.08
1347335—1951-52, D41-42 (right*)	4.65
1435495—1953, D44, 46 (right*)	1.85
1456608—1953, D47, 48 (right*)	1.85
4 WINDSHIELD OUTSIDE MOLDING	
1242328—1949, 2 d. sed. (right*)	2.37
1256329—1949-50, club cpe. (right*)	3.89
1369556—1951-52, 2 d. sed. (right*)	2.37
1369554—1951-52, 3 cpe., club cpe. (upper right*)	2.47
1371379—1951-52, 2 d. sed., 3 cpe., club cpe. (lower right*)	2.10
1492194—1953, conv. up.	1.75
1474823—1953, exc. conv. (right*)	1.88
1492272—1953, conv. (right*)..
1477568—1953, exc. conv. up... ..	1.85
5 WINDSHIELD DIVISION BAR	
1243904—1949-50, 3 cpe., club cpe.	2.03
1242318—1949-50, 2 d. sed....	1.04
1333210—1950, 3 cpe.	1.09
1371487—1951-52, 2 d. sed....	2.03
1371892—1951-52, 3 cpe, club cpe.	2.03

continued

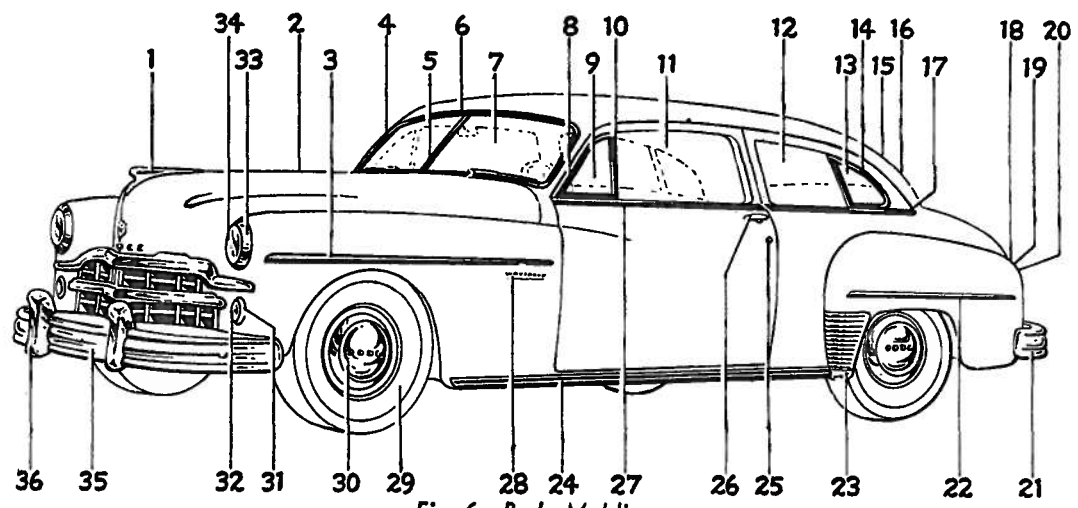

Fig. 6—Body Moldings

* Opposite side one part number higher

DODGE 1949 thru 1953 BODY PARTS**ALL BODY STYLES****Body Moldings—continued****6 WINDSHIELD OUTSIDE MOLDING
UPPER CLIP**

1256331—1949, 2 d. sed., club cpe.38
1369539—1950 to 52, 2 d. sed., 3 cpe., club cpe.27

7 WINDSHIELD GLASS

1243579—1949-50, 2 d. sed., 3 cpe., club cpe.	P.O.A.
1242323—1950, 2 d. sed.	P.O.A.
1336097—1951-52, 2 d. sed. ...	P.O.A.
1336096—1951-52, 3 cpe., club cpe.	P.O.A.
1371984—1953, 2 dr., cl. cpe. ..	P.O.A.
1432404—1953, D47, 48, exc. conv.	P.O.A.
1478153—1953, conv.	P.O.A.

8 DOOR VENT WING GLASS FRAME

1242320—1949, 2 d. sed. (right*)	3.16
1336005—1950 to 52, 2 d. sed. (right*)	3.16
1309113—1949 to 52, 3 cpe. (right*)	3.16
1309134—1949 to 52, club cpe (right*)	4.41
1433312—1953, 2 dr., 3 cpe. (right*)	3.00
1497020—1953, cl. cpe. (right*)	4.15
1477704—1953, conv. (right*)..	5.05
1477706—1953, spec. cpe. (right*)	5.05

9 DOOR VENT WING GLASS

1242310—1949, 2 d. sed.	P.O.A.
1302180—1949, 3 cpe., club cpe.	P.O.A.
1309138—1950 to 52, 3 cpe., club cpe.	P.O.A.
1306500—1951-52,, 2 d. sed....	P.O.A.
1455364—1953, 2 dr., cl. cpe., 3 cpe.	P.O.A.
1457272—1953, conv.	P.O.A.
1457273—1953, spec. cpe.	P.O.A.

**10 DOOR VENT WING WEATHERSTRIP
RETAINER**

1242278—1949-50, 2 d. sed. (right*)	4.16
1308953—1949 to 52, 3 cpe., club cpe. (right*)	4.16
1385547—1951-52, 2 d. sed. (right*)	4.68
1385561—1951-52, 3 cpe. (right*)	4.68
1385559—1951-52, club cpe. (right*)	4.68
1455200—1953, 2 dr., 3 cpe., cl. cpe. (right*)	1.95
1459866—1953, conv. (right*)..	2.75
1459252—1953, spec. cpe. (right*)	2.75

**DOOR DIVISION CHANNEL INNER
MOLDING**

1242425—1949, 2 d. sed.68
1296602—1949 to 52, 3 cpe., club cpe.68
1455369—1953, 2 dr., 3 cpe., cl. cpe., in. & out.40

1459087—1953, spec. cpe.40
1459425—1953, conv.40

**DOOR DIVISION CHANNEL OUTER
MOLDING**

1242426—1949, 2 d. sed.63
1296601—1949 to 52, 3 cpe., club cpe.63
1459456—1953, spec. cpe.35
1459262—1953, conv.35

11 DOOR GLASS

1302226—1949 to 52, 2 d. sed., 3 cpe., club cpe.	P.O.A.
1242270—1950 to 52, 2 d. sed. ...	P.O.A.
1455364—1953, 2 dr., 3 cpe., cl. cpe.	P.O.A.
1457272—1953, conv.	P.O.A.
1457273—1953, spec. cpe.	P.O.A.

12 REAR QUARTER WINDOW GLASS

1242313—1949 to 52, 2 d. sed. ...	P.O.A.
1240553—1950 to 52, club cpe.	P.O.A.
1438746—1953, 2 dr., cl. cpe. ..	P.O.A.
1457139—1953, conv. cpe.	P.O.A.
1458280—1953, spec. cpe.	P.O.A.

13 REAR QUARTER WINDOW GLASS

1242405—1949 to 52, 2 d. sed., stationary glass	P.O.A.
---	--------

**14 REAR QUARTER WINDOW
MOLDING**

1242455—1949 to 52, 2 d. sed. (right*)	6.35
1438971—1953, 2 dr., cl. cpe. (right*)
1438972—1953, cl. cpe. (right*)
1433974—1953, conv. (right*)..	4.85
1433978—1953, spec. cpe. (right*)	4.85

**15 REAR WINDOW GLASS
WEATHERSTRIP**

1242299—1949-50, 2 d. sed. ...	6.47
1242096—1949, 3 cpe.	5.88
1244039—1949, club cpe.	4.26
1336032—1950, 3 cpe.	4.04
1333683—1950, club cpe.	4.26
1342019—1950 to 52, spec. club cpe.	12.72
1371751—1951-52, 2 d. sed. ...	10.36
1364431—1951-52, 3 cpe.	4.78
1366347—1951-52, club cpe. ...	5.93
1438953—1953, 2 dr., cl. cpe. ...	8.12

16 REAR WINDOW GLASS

1242020—1949, 3 cpe.	P.O.A.
1240447—1949, club cpe.	P.O.A.
1242379—1949 to 52, 2 d. sed. ...	P.O.A.
1336041—1950 to 52, 3 cpe. ...	P.O.A.
1333624—1950, club cpe.	P.O.A.
1334362—1950, spec. club cpe. side (right*)	P.O.A.
1342182—1950, spec. club cpe. center	P.O.A.
1369277—1951-52, 2 d. sed. ...	P.O.A.
1366369—1951-52, club cpe. ...	P.O.A.
1331354—1951-52, conv. cpe., roadster (rear curtain) ...	14.35
1438944—1953, 2 dr., 3 cpe., cl. cpe.	P.O.A.

1497915—1953, conv.	P.O.A.
1458126—1953, spec. cpe. (right*)	P.O.A.
1458123—1953, spec. cpe. (center)	P.O.A.

17 QUARTER PANEL BELT MOLDING

1242415—1949 to 52, 2 d. sed. (right*)	2.84
1242411—1949 to 52, 3 cpe. (right*)	4.16
1256174—1949 to 52, clb cpe. (right*)	4.58
1348724—1950 to 52, spec. club cpe., upper	1.05

18 TAIL LAMP SHELL

1257308—1949, 2 d. sed. (right*)	5.29
1244878—1949, 3 cpe and roadster (right*)	2.63
1300547—1949, club cpe. (right*)	10.20

18 TAIL AND STOP BEZEL

1343181—1950, 2 d. sed. (right*)	6.70
1340351—1950 to 52, 3 cpe., club cpe., spec. club cpe. (right*)	3.55
1479202—1953, conv. spec. cpe. (stamping)	5.10
1479156—1953, conv., spec. cpe. (casting)	4.85

18 TAIL LAMP HOUSING

1257330—1949, 2 d. sed. (right*)	1.15
1253158—1949, 3 cpe. and roadster (right*)	1.05
1340498—1950 to 52, 2 d. sed. (right*)	1.05
1334039—1950 to 52, 3 cpe., c. cpe., spec. c. cpe. (right*) ..	1.15
1340343—1950 to 52, 8 cpe., c. cpe., spec. c. cpe. (right*)..	2.95
1439890—1953, exc. sub.	1.65

TAIL LAMP LENS GASKET

1257324—1949 to 1951-52, 2 d. sed.11
1253147—1949, 3 cpe. and roadster11
1300927—1949, club cpe. and conv. cpe.28
1340499—1950 to 52, 2 d. sed.15
13403353—1950 to 52, 3 cpe., c. cpe., conv. cpe., spec. c. cpe.45

19 TAIL LAMP LENS

1244881—1949, 3 cpe and roadster92
1257323—1949 to 1951-52, 2 d. sed.95
1300555—1949, club cpe and conv. cpe. (right*)	1.49
1340191—1950 to 52, 2 d. sed., early (right*)	1.12
1340347—1950 to 52, 3 cpe., c. cpe., spec. c. cpe., conv. cpe. (right*)	1.26
1439899—195360

* Opposite side one part number higher

BODY PARTS 1949 thru 1953 DODGE

ALL BODY STYLES

20 TAIL LAMP BUTTON REFLECTOR	
1235512—1949 to 51-53, D29-41	.21
1300840—1949, club cpe and conv. cpe.74
1300500—1950 to 5290
21 REAR BUMPER FACE BAR	
1137698—1949-50, 2 d. sed. ...	42.75
1319565—1950, exc. 2 d. sed. ...	42.75
1321725—1951-52, exc. 2 d. sed. ...	42.75
1324011—1951-52, 2 d. sed. ...	42.75
1402888—1953, D44, 46	42.75
1329457—1953, D48	34.95
22 REAR FENDER MOLDING	
1252833—1949, D 30 (right*) ..	3.74
1333837—1950, exc. 2 d. sed. ...	4.11
1333935—1950 to 52, 2 d. sed. ...	4.11
1364970—1951-52, 3 cpe. and roadster (right*)	4.46
1371997—1951-52, roadster, late (right*)	4.46
1438852—1953, 2 dr., cl. cpe. (right*)	1.60
1492090—1953, conv., spec. cpe. (right*)	1.50
23 REAR FENDER STONE SHIELD	
1334353—1949, D29-30, exc. 2 d. sed. (right*)	8.05
1298710—1949-50, 2d. sed. (right*)	7.14
1333975—1950, club cpe. (right*)	7.20
1341150—1950, spec. club cpe. and conv. cpe. (right*)	8.74
1364523—1951-52, club cpe. (right*)	6.08
1367698—1951-52, spec. club cpe. and conv. cpe. (right*) ..	9.25
1476087—1953, D44, 46	4.65
24 BODY SIDE SILL MOLDING	
1256002—1949, club cpe.	10.34
1242493—1949, 2 d. sed., 3 cpe. (right*)	9.22
1303271—1949, conv. cpe. (right*)	10.34
1334075—1950, 2 d. sed., 3 cpe., roadster (right*)	8.68
1333987—1950, club cpe., use w/o fender shield (right*) ..	9.22
1333994—1950, club cpe. spec. club cpe., use w/fender shield (right*)	10.07
1364909—1951-52, 2 d. sed., 3 cpe., roadster (right*)	9.75
1364852—1951-52, club cpe., spec. club cpe., early (right*) ..	11.03
1364813—1951-52, club cpe., late (right*)	10.28
1432752—1951-52, spec. club cpe., late (right*)	10.28
25 DOOR LOCK CYLINDER AND KEY PACKAGE	
1315510—1949 to 52	2.21
26 DOOR OUTSIDE HANDLE	
1254294—1949 to 52, 2 d. sed., 3 cpe., club cpe. (right*)	3.00
1386083—1951-52, 2 d. sed., 3 cpe., late (right*)	2.52
1248019—1949 to 52, conv. cpe., roadster, spec. club cpe.	3.17
1433104—1953, all	2.80

27 DOOR BELT MOLDING	
1256172—1949-50, club cpe. (right*)	3.04
1242362—1949-50, 2 d. sed., 3 cpe. (right*)	2.84
1242354—1949, 2 d. sed.
1336708—1950, conv. cpe., spec. club cpe. (right*)	4.26
1369282—1951-52, 2 d. sed., 3 cpe. (right*)	2.84
1369510—1951-52, club cpe. (right*)	3.04
1368232—1951-52, conv. cpe., spec. club cpe. (right*)	2.68
28 FRONT FENDER SIDE NAME PLATE	
1301385—1949-50, Coronet, fluid drive	3.18
1301386—1949-50, Coronet, gyro-matic	3.18
1300171—1949 to 52, Wayfarer, fluid drive	1.98
1434647—1951-52, Wayfarer, gyro-matic	2.65
1347323—1951-52, Coronet, fluid drive	2.20
1347349—1951-52, Coronet, gyro-matic	2.22
1456428—1953, D44, 48, Coronet	1.10
1456429—1953, D46, 47, Meadowbrook	1.10
29 FRONT AND REAR WHEEL	
1316710—1949 to 53, D29-33-41 (15x4.50)	10.60
1270660—1949 to 53, D-30-34-D42 (15x5.00)	13.50
30 WHEEL HUB CAP	
1117382—1949-50, D29-30-33-34	3.70
1117383—1949-50, D30-34	4.05
1324130—1951-52, D43	3.25
1324129—1951-52, D41-42	2.85
1487536—1953, D46, 47	2.95
1487537—1953, D44, 48	2.95
WHEEL COVER	
1321596—1949-50, D30-34	8.25
1324550—1951-52, D42	8.24
1488431—1953, D44, 48	8.24
31 PARKING LAMP BEZEL	
1297833—1949	2.11
1339788—1950	2.25
1343758—1951-52	2.25
32 PARKING LAMP LENS	
1297832—194972
1339785—195072
1343760—1951-5275
1440340—1953, all	1.69
PARKING LAMP LENS MOUNTING GASKET	
1297836—194911
1339786—195040
1343761—1951 to 5340
PARKING LAMP HOUSING	
1297829—1949	1.69
1339789—1950	2.60
1343762—1951-5215
1343756—1953, all	2.48

33 HEADLAMP DOOR	
1239411—1949-50	2.50
1345670—1951 to 53	3.95
SEALED BEAM UNIT RETAINING RING	
946942—1949 to 53	1.82
34 SEALED BEAM UNIT	
1297667—1949 to 53, Bullseye lens	1.95
853369—1949-50 plain lens ...	1.65
HEADLAMP BULB MOUNTING SEAT	
946940—1949 to 53	1.78
HEADLAMP SHELL	
1154200—1949 to 53	3.26
HEADLAMP MOUNTING GASKET	
1310488—1949 to 5321
HEADLAMP CABLE AND SOCKET	
1310740—1949 (right*)	2.42
1340257—1950 to 53	2.59
35 FRONT BUMPER FACE BAR	
1137745—1949-50	39.11
1321720—1951-52	39.11
1329450—1953, D47, 48	32.95
1312720—1953, D44, 46	39.11
36 BUMPER BUFFER PLATE	
1141805—1949 (right*)	6.80
1319585—1950, exc. spec. club cpe. (right*)	6.35
1324626—1951-52 (right*) ...	6.63
1483148—1953 (right*)	6.35

Body Sheet Metal and Fuel Tank

*2-Door Sedans and Coupes
See Fig. 7*

1 COWL SIDE PANEL	
1240722—1949-50, (right*) ...	20.45
1247868—1950, spec. club cpe. (right*)	12.35
1385126—1951-52 (right*) ...	12.35
1440828—1953, 2 & 4 dr, 3 cpe, cl. cpe. (right*)
1947543—1953, conv. up.
1492602—1953, spec. cpe. (right*)
2 DASH PANEL ASSEMBLY	
1244135—1949	11.00
1336361—1950	11.00
1371148—1951-52	11.00
1475379—1953, D44, 46	3.45
1497141—1953, D47
1497142—1953, D48
3 DOOR REPAIR PANEL	
1333036—1949, 3 cpe., club cpe., (right*)	12.23
1334829—1950 (right*)	14.26
1371651—1951-52, 2 d. sed. (right*)	14.63
1371649—1951-52, 3 cpe., club cpe. (right*)	14.63
1348413—1951-52, spec. club cpe. (right*)	14.63

continued

* Opposite side one part number higher

DODGE 1949 thru 1953 BODY PARTS**ALL BODY STYLES**

Fig. 7—Body Sheet Metal

Body Sheet Metal and Fuel Tank—continued**4 BODY SIDE SILL OUTER PANEL**

1242358—1949-50, 2 d. (right*)	6.62
1242084—1949-50, 3 cpe. (right*)	6.88
1240645—1949-50, club cpe. (right*)	6.88
1249386—1950, spec. club cpe. (right*)	6.88
1336079—1951-52, 2 d. (right*)	6.62
1334910—1951-52, club cpe. (right*)	6.74
1348764—1951-52, spec. club cpe. (right*)	6.74

5 BODY SIDE SILL INNER PANEL

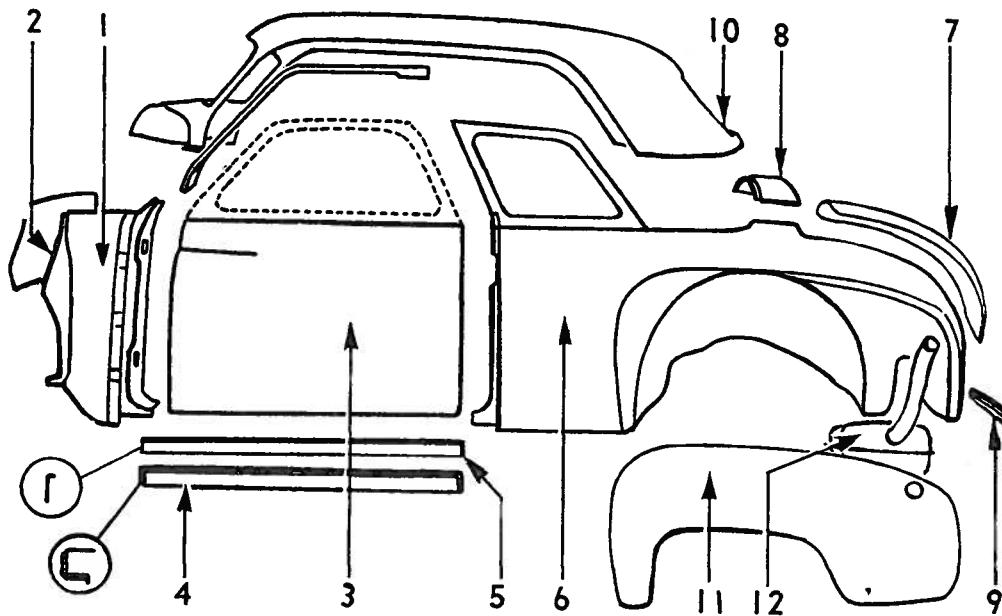
1242082—1949 to 52, 2 d., 3 cpe. (right*)	5.26
1240643—1949 to 52, club cpe. (right*)	5.26
1304287—1950 to 52, spec. club cpe. (right*)	8.57
1523020—1953, 2 dr., cl. cpe. (right*)	5.25

6 REAR QUARTER PANEL

1306715—1949 to 50, 2 d. sed. (right*)	80.05
1306713—1949 to 52, 3 cpe. (right*)	60.18
1340813—1949-50, club cpe. (right*)	80.05
1333015—1951-52, 2 d. sed. (right*)	80.00
435600—1951-52, club cpe. (right*)	78.33
1431986—1950 to 52, spec. club cpe. (right*)	80.49
1525670—1953, spec. cpe. (right*)	82.25

7 LUGGAGE COMPARTMENT LID

1242236—1949, 2 d. sed.	37.00
1242237—1949, 3 cpe.	43.62
1333724—1949, club cpe.	40.31
1331858—1950, 2 d. sed.	43.62
1331859—1950 to 52, 3 cpe.	43.62
1372260—1951-52, 2 d. sed.	36.21
1331856—1950 to 52, club cpe. and spec. club cpe.	40.31
1528033—1953, D44, 46	43.00
1527998—1953, D47, 48	42.25

8 LUGGAGE COMPARTMENT OPENING UPPER PANEL

1239066—1949, club cpe.	7.72
1242740—1950, club cpe.	7.72
1342423—1950 to 52, spec. club cpe.	15.67
1340680—1951-52, 3 cpe.	7.47
1334169—1951-52, club cpe.	7.89
1432916—1953, 2 dr., spec. cpe.	9.85
1440844—1953, conv.	

9 LUGGAGE COMPARTMENT OPENING LOWER PANEL

1241331—1949 to 52, 3 cpe., club cpe., spec. club cpe.	3.89
1240842—1949 to 52, 2 d. sed.	5.26
1528028—1953, 4 dr., 2 dr., cl. cpe.	10.75
1528174—1953, cy. cp. spe. cl. cp.	13.50

10 ROOF PANEL ASSEMBLY

1240849—1949-50, 2 d. sed.	129.71
1306670—1949, 3 cpe.	128.78
1242722—1949, club cpe.	
1340697—1950, 3 cpe.	128.78
1340828—1950, club cpe.	129.71
1433715—1950, spec. club cpe.	115.20
1366817—1951-52, 2 d. sed.	129.71
1366816—1951-52, 3 cpe.	128.78
1435603—1951-52, club cpe.	126.93
1349193—1951-52, spec. club cpe.	117.73

1528043—1953, 4 dr.	129.70
1528044—1953, 2dr., 3 cpe., cl. cpe.	129.70
1526289—1953, spec. cpe.	143.75

10 ROOF REPAIR PANEL

1306533—1949-50, 2 d. sed.	37.00
1308748—1950, club cpe.	37.00

11 REAR FENDER

1242460—1949, 2 d. sed. (right*)	19.48
1252777—1949, D29 exc. 2 d. sed. (right*)	19.48
1372061—1950, D33 exc. 2 d. sed. (right*)	19.48
1242460—1950 to 52, 2 d. sed. (right*)	19.48
1372061—1951-52 (right*)	19.48
1493083—1953, spec. cpe. (right*)	82.25

12 FUEL TANK

1138587—1949 to 52	16.25
1483601—1953	16.25

FUEL TANK SUPPORT STRAP

1126688—1949 to 52	.75
1401502—1953	.85

Body Moldings

Conv. Coupe, Spec. Club Coupe and Roadster

See Fig. 8

1 HOOD TOP ORNAMENT

1298935—1949-50	7.95
-----------------	------

HOOD TOP ORNAMENT BASE

1373215—1951-52	5.01
1456250—1953, all	5.01

ORNAMENT HORN

1373213—1951-52 (right*)	2.35
1373283—1953 (right*)	2.35

* Opposite side one part number higher

BODY PARTS 1949 thru 1953 DODGE

ALL BODY STYLES

2 HOOD TOP MOLDING		8 WINDSHIELD GLASS		1433738—1953, spec. cpe. up. 4.05	
1298954—1949-50	2.22	1246583—1949 to 52, conv. cpe., spec. club cpe., roadster	P.O.A.	1433632—1953, spec. cpe. (right*)	4.40
1347293—1951-52	2.10	1432404—1953, exc. conv.			
3 FRONT FENDER SIDE MOLDING		9 DOOR VENT WING GLASS FRAME		12 DOOR GLASS	
1256508—1949, D29 (right*)	3.67	1342476—1949-50, conv. cpe., spec. club cpe., roadster (right*)	9.41	1246836—1949, conv. cpe.	P.O.A.
1256512—1949, D30 (right*)	3.67	1380350—1951-52, conv. cpe., spec. club cpe., roadster (right*)	9.41	1308760—1949, roadster (plastic)	P.O.A.
1335282—1950, D33, roadster (right*)	4.08	1497020—1953, cl. cpe. (right*)	4.15	1386553—1950, conv. cpe., spec. club cpe.	P.O.A.
1335306—1950, D33, exc. road- ster (right*)	4.08	1477704—1953, conv. (right*)	5.05	1373930—1951-52, roadster	P.O.A.
1347335—1951-52 (right*)	4.65	1477706—1953, spec. cpe. (right*)	5.05	1381298—1951-52, conv. cpe., spec. club cpe.	P.O.A.
1435495—1953, D44, 46 (right*)	1.85	DOOR VENT WING FRAME		1433358—1953, spec. cpe.	P.O.A.
1456608—1953, D47, 48 (right*)	1.85	1308787—1949, roadster (right*)	23.76	1433359—1953, conv.	P.O.A.
4 WINDSHIELD OUTSIDE UPPER MOLDING		1246958—1949, conv. cpe., spec. club cpe. (right*)	25.96	13 QUARTER WINDOW GLASS FRAME	
1303246—1949 to 52, conv. cpe., spec. c. cpe., roadster (right*)	7.20	1342472—1950, roadster (right*)	25.96	1248778—1949-50 conv. cpe., spec. club cpe. (right*)	21.82
1477568—1953, up.	1.85	1380342—1951-52, conv. cpe., spec. club cpe., roadster (right*)	26.80	1380191—1951-52 (front), conv. cpe., spec. club cpe.	4.36
1477718—1953, side (right*)	2.50	1477744—1953, conv. (right*)	17.95	1380190—1951-52 (upper and rear), conv. cpe., spec. club cpe.	8.67
5 WINDSHIELD OUTSIDE LOWER MOLDING		1477600—1953, spec. cpe. (right*)	17.95	1458726—1953, conv. (front)	7.25
1248846—1949 to 52, conv. cpe., spec. c. cpe., roadster (right*)	2.68	10 DOOR VENT WING GLASS		1458053—1953, conv. (up. & rear)	5.50
1477569—1953, conv.	2.00	1246981—1949, conv. cpe.	P.O.A.	1458690—1953, spec. cpe. (front)	7.25
6 WINDSHIELD DIVISION BAR		1342480—1950 to 52 conv. cpe., spec. club cpe.	P.O.A.	1458829—1953, spec. cpe. (up. & rear)	5.50
1247620—1949 to 52, conv. cpe., spec. club cpe., roadster	1.96	1380490—1951-52, roadster	P.O.A.	14 QUARTER WINDOW GLASS	
1306589—1950 to 52, roadster	1.31	1457272—1953, conv.		1246871—1949 to 52, conv. cpe., spec. club cpe.	P.O.A.
1381899—1951-52, conv. cpe. and spec. club cpe.	1.96	1457273—1953, spec. cpe.		1380187—1951-52, conv. cpe., spec. club cpe.	P.O.A.
7 WINDSHIELD UPPER MOLDING JOINT CLIP		11 DOOR GLASS FRAME		1457139—1953, conv.	P.O.A.
1256331—1949, roadster38	1246832—1949-50, conv. cpe., spec. club cpe. (right*)	20.43	1458280—1953, spec. cpe.	P.O.A.
1303488—1949 to 52, conv. cpe. and spec. club cpe.32	1373928—1951-52, roadster (right*)	19.70	15 REAR WINDOW OUTSIDE MOLDING	
1474826—1953, cl. cpe.32	1380206—1951-52, conv. cpe., spec. club cpe. (right*)	14.97	1342210—1950 to 52 (side right*)	2.37
WINDSHIELD LOWER MOLDING JOINT CLIP		1433737—1953, conv. up.	4.05	1342194—1950 to 52 (lower center)	3.10
1256332—1949, roadster38	1433630—1953, conv. (right*)	4.40	1342024—1950 to 52 (upper center)	3.10
1303490—1949 to 52, conv. cpe., spec. club cpe. and roadster32	<i>continued</i>			
WINDSHIELD LOWER SIDE JOINT MOLDING CLIP					
1248851—1949, conv. cpe. and roadster38				

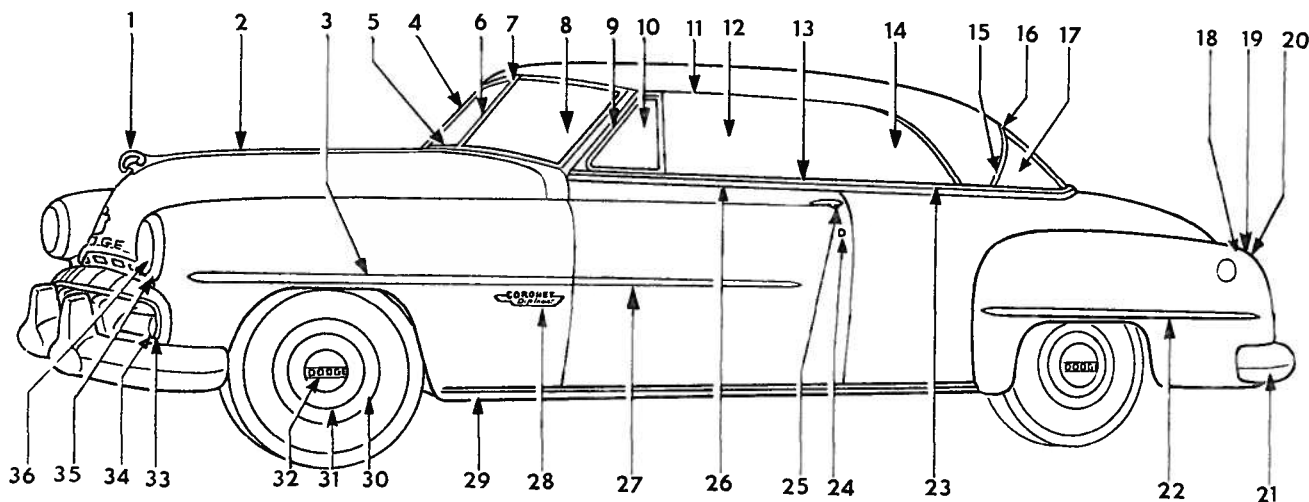

Fig. 8—Body Moldings

* Opposite side one part number higher

DODGE 1949 thru 1953 BODY PARTS**ALL BODY STYLES****Body Moldings—continued**

1342268—1950 to 52 (lower end right*)	2.37	21 REAR BUMPER FACE BAR	1434647—1951-52, Wayfarer, gyro-matic	2.6
1491080—1953, spec. cpe. (up. right*)	1.95	1137698—1949, D29-30	1347323—1951-52, Coronet, fluid drive	2.9
1491804—1953, spec. cpe. (low right*)	1.95	1319565—1950, D33-34	1347349—1951-52, Coronet, gyro-matic	2.9
16 REAR WINDOW DIVISION BAR		1321725—1951-52, D41-42	1347324—1951-52, Coronet-Diplomat, spec. club cpe.	2.9
1348710—1951-52	1.15	1402888—1953, D44, 46	1456428—1953, Coronet	1.1
17 REAR WINDOW GLASS		1329457—1953, D48	1456429—1953, Meadowbrook ..	1.1
1334362—1950 (side right*) ..	P.O.A.	22 REAR FENDER MOLDING	29 BODY SIDE SILL MOLDING	
1342182—1950 (center)	P.O.A.	1252833—1949, D30 (right*) ..	1242493—1949, roadster (right*)	9.2
1458126—1953, spec. cpe. (right*)	P.O.A.	1333837—1950, D33-34	1303271—1949, conv. cpe. (right*)	10.3
1458123—1953, spec. cpe. (center)	P.O.A.	1364970—1951-52, D41-42 (right*)	1334075—1950, roadster, use w/o fender shield (right*) ..	8.6
REAR CURTAIN LIGHT		1371997—1951-52, D41-42 (right*)	1333994—1950 to 52, conv. cpe., spec. club cpe., use w/fender shield (right*)	10.0
1331354—1949 to 52, conv. cpe. and roadster	14.35	23 QUARTER PANEL OUTSIDE MOLDING	1334138—1950, roadster, use w/fender shield (right*) ...	8.4
1497915—1953, conv.	12.40	1303284—1949 to 52, rear, conv. cpe. (right*)	1364909—1951-52, roadster (right*)	9.7
18 TAIL LAMP SHELL		1336586—1950, front, conv. cpe. (right*)	1364852—1951-52, conv. cpe. and spec. club cpe. (right*) ..	11.0
1300898—1949, conv. cpe. (right*)	9.67	1348724—1950 to 52, upper, spec. club cpe.	1432752—1951-52, conv. cpe., spec. club cpe., late (right*) ..	10.2
1244878—1949, roadster (right*)	2.63	1380712—1950 to 52, front, spec. club cpe. (right*)	30 WHEEL ASSEMBLY	
TAIL LAMP BEZEL		1953, see item No. 22	1316710—1949 to 53, D29-33-41 (15 x 4.50)	10.6
1340351—1950 to 52, conv. cpe., spec. club cpe., roadster (right*)	3.55	24 DOOR LOCK CYLINDER AND KEYS PACKAGE	1270660—1950 to 53, D30-34-42 (15 x 5.00)	13.1
1436503—1951-52, roadster (late) (right*)	4.45	1315510—1949 to 52	31 WHEEL COVER	
1479202—1953, conv. spec. cl. cpe.	5.10	25 DOOR OUTSIDE HANDLE	1321598—1949-50, D33-34	8.5
18 TAIL LAMP HOUSING		1248019—1949 to 52, conv. cpe., spec. club cpe., roadster	1324550—1951-52, D42	8.5
1253158—1949, roadster (right*)	1.05	1433104—1953, all	1488431—1953, D44, 48	8.5
1334039—1950, conv. cpe., spec. club cpe., roadster (right*) ..	1.15	26 DOOR UPPER MOLDING	32 WHEEL HUB CAP	
1340343—1950 to 52, conv. cpe., spec. club cpe., roadster (right*)	2.95	1298496—1949, roadster (right*)	1117383—1949-50, D30-34	4.1
1436497—1951-52, roadster, late (right*)	3.25	1303301—1949, conv. cpe. (right*)	1324130—1951-52, D42	4.1
1439890—1953, all	1.65	1242155—1950, roadster (right*)	1487536—1953, D46, 47	2.1
18 TAIL LAMP LENS GASKET		1336708—1950, conv. cpe. and spec. club cpe. (right*)	1487537—1953, D44, 48	3.1
1253147—1949, roadster11	1336710—1950, white, conv. cpe. (right*)	33 PARKING LAMP BEZEL	
1300927—1949, conv. cpe.28	1368232—1951-52, conv. cpe., spec. c. cpe., roadster (right*)	1297833—1949	2.1
1340353—1950 to 52, conv. cpe., spec. club cpe., roadster45	27 DOOR FENDER EXTENSION MOLDING	1339788—1950	2.1
1439893—1953, all30	1252525—1949, conv. cpe. (right*)	1343758—1951-52	2.1
19 TAIL LAMP LENS		1333764—1950, conv. cpe., spec. club cpe., roadster	34 PARKING LAMP LENS	
1244881—1949, roadster92	1371300—1951-52, conv. cpe., spec. club cpe., roadster (right*)	1297832—1949	1.1
1300555—1949, conv. cpe. (right*)	1.49	1492078—1953, dr. side (right*) ..	1339785—1950	1.1
1340347—1950 to 52, conv. cpe., spec. club cpe., roadster (right*)	1.26	28 FRONT FENDER SIDE NAME PLATE	1343760—1951-52	1.1
1439899—1953, all60	1301385—1949-50, Coronet, fluid drive	1440340—1953	1.1
20 TAIL LAMP BUTTON REFLECTOR		1301386—1949-50, Coronet, gyro-matic	34 PARKING LAMP LENS MOUNTING GASKET	
1235512—1949, roadster, 1953, all21	1300171—1949 to 52, Wayfarer, fluid drive	1297836—1949	1.1
1300840—1949, conv. cpe.74	1335967—1950 to 52, Sport-about roadster	1339786—1950	1.1
1300500—1950 to 52, D3490	1335970—1950, Coronet-Diplomat, spec. club cpe.	1343761—1951 to 53	1.1
1253173—1951-52, D41-4221		34 PARKING LAMP HOUSING	
			1297829—1949	1.1
			1339789—1950	2.1
			1343755—1951-52	2.1
			1343756—1953	2.1
			35 HEAD LAMP DOOR	
			1239411—1949-50	2.1
			1345670—1951 to 53	3.1

* Opposite side one part number higher

BODY PARTS 1949 thru 1953 DODGE ALL BODY STYLES

HEAD LAMP BULB RETAINING RING	
946942—1949 to 53	1.82
SEALED BEAM UNIT	
1297667—1949 to 53, bull's-eye lens	1.95
853369—1950, plain lens	1.65
SEALED BEAM UNIT MOUNTING SEAT	
946940—1949 to 52.....	1.78
HEADLAMP SHELL	
1154200—1949 to 53	3.26

Body Sheet Metal and Fuel Tank

Convertible Coupe and Roadster
See Fig. 9

COWL UPPER PANEL	
1306671—1949, roadster	47.30
1303121—1949, conv. cpe.	47.30
1247865—1950, conv. cpe.	47.30
1385263—1951-52, roadster ...	55.19
1349036—1951-52, conv. cpe....	55.19
1497543—1953, all	72.50
COWL SIDE PANEL	
1247868—1949-50, conv. cpe., roadster (right*)	9.72
1349016—1951-52, conv. cpe., roadster (right*)	9.77
1528190—1953, spec. cpe. (right*)	22.40
DASH PANEL	
1244135—1949, conv. cpe., roadster	11.00
1336361—1950, conv. cpe., roadster	11.00

1371148—1951-52, conv. cpe., roadster	11.00
1528111—1953, D44, 46	11.00
1528159—1953, D47	21.28
1528165—1953, D48	15.25
4 DOOR REPAIR PANEL	
1333036—1949, conv. cpe., roadster (right*)	12.23
1334829—1950, conv. cpe. (right*)	14.26
1242482—1950, roadster (right*)	13.30
1348413—1951-52, conv. cpe., roadster (right*)	14.63
5 BODY SIDE SILL INNER PANEL	
1309361—1949 to 52, roadster (right*)	8.57
1304287—1949 to 52, conv. cpe. (right*)	8.57
1433134—1953, conv. (right*) ..	9.95
6 BODY SIDE SILL OUTER PANEL	
1242132—1949-50, roadster (right*)	6.62
1249386—1949-50, conv. cpe. (right*)	6.88
1348764—1951-52, conv. cpe. (right*)	6.74
1364507—1951, roadster (right*)	6.62
7 LUGGAGE COMPARTMENT LID	
1242237—1949, roadster	43.62
1303163—1949, conv. cpe.	40.31
1331859—1950 to 52, roadster ..	43.62
1331856—1950 to 52, conv. cpe. ..	40.31
1528033—1953, D44, 46	43.00
1527998—1953, D48	42.25

8 REAR QUARTER PANEL	
1249698—1949, conv. cpe. (right*)	82.25
1341232—1950, conv. cpe. (right*)	82.25
1306725—1950 to 52, roadster (right*)	74.53
1332794—1951-52, conv. cpe. (right*)	87.12
1525670—1953, spec. cpe. (right*)	82.25
9 LUGGAGE COMPARTMENT OPENING UPPER PANEL	
1242053—1949 to 52, roadster ..	6.88
1248422—1949, conv. cpe.	10.78
1342013—1950, conv. cpe.	5.52
1367491—1951 to 52, conv. cpe ..	11.56
1432916—1953, spec. cpe.	9.85
1528174—1953, conv.	13.50
10 LUGGAGE COMPARTMENT OPENING LOWER PANEL	
1241331—1949 to 52, conv. cpe., roadster	3.89
11 REAR FENDER	
1252777—1949 (right*)	19.48
1372061—1950 (right*)	19.48
1372061—1951-52 (right*) ...	19.48
11 REAR FENDER BRACE	
1243997—1949 (right*)47
1334348—1950 to 52 (right*)..	.52
12 FUEL TANK ASSY.	
1138587—1949 to 52	16.25
1483601—1953	16.25
13 ROOF PANEL	
1433715—1950, spec. club cpe..	115.20
1349193—1951-52, spec. club cpe.	117.73
1526289—1953, spec. cpe.	143.75

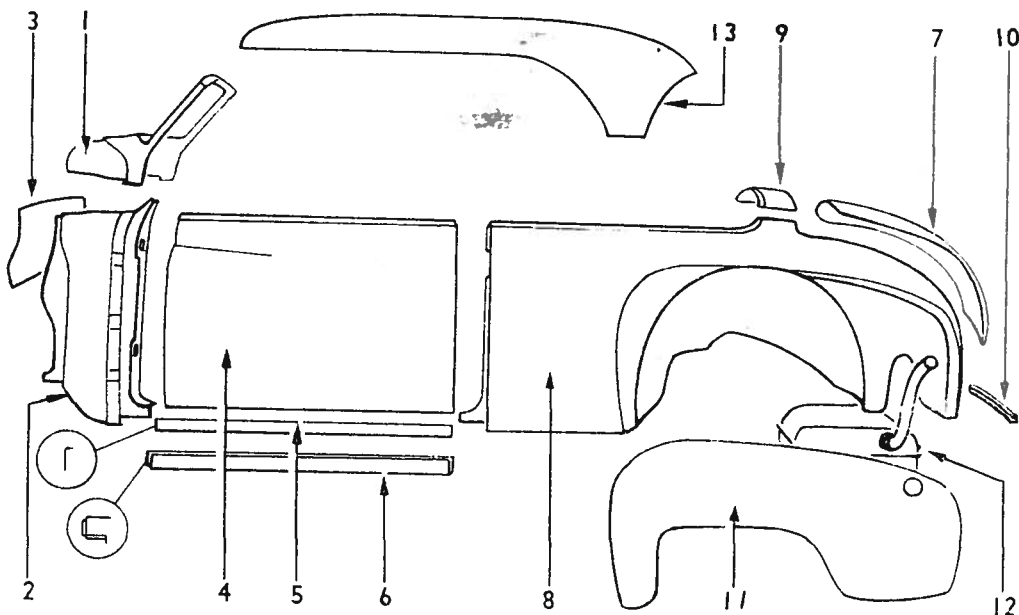

Fig. 9—Body Sheet Metal

* Opposite side one part number higher

DODGE 1949 thru 1953 BODY PARTS

ALL BODY STYLES

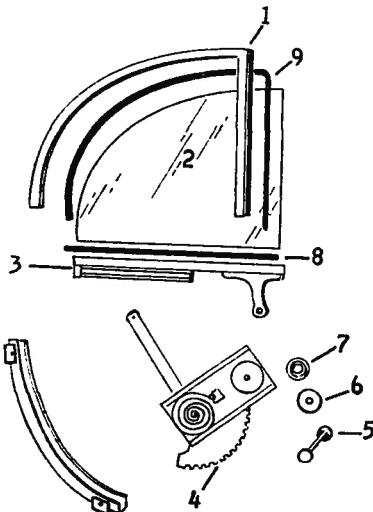

Fig. 10—Quarter Window

Quarter Window Assembly

Convertible Models See Fig. 10

1 QUARTER WINDOW GLASS FRAME	
1248778—1949-50 (right*) ...	21.82
1380190—1951-52, upper and rear	8.67
1380191—1951-52, front	4.36
1458726—1953, conv. (front) ...	7.25
1458053—1953, conv. (up. & rear)	5.50
1458690—1953, spec. cpe (front) ...	7.25
1459421—1953, spec. cpe. (up. & rear)	5.65
2 WINDOW GLASS	
1246871—1949-50	P.O.A.
1380187—1951-52	P.O.A.
1457139—1953, conv.	P.O.A.
1458280—1953, spec. cpe.	P.O.A.
3 WINDOW GLASS LOWER CHANNEL	
1249060—1949-50 (right*) ...	6.52
1380182—1951-52 (right*) ...	7.20
1458104—1953 (right*)	3.95
4 WINDOW REGULATOR	
1248874—1949 to 52 (right*)..	4.16
1457206—1953 (right*)	6.75
5 WINDOW REGULATOR HANDLE	
1296582—1949-50	1.84
1298148—1951 to 53	2.39
6 REGULATOR HANDLE ESCUTCHEON	
1296570—1949-5074
1256038—1951 to 5337
7 REGULATOR HANDLE ESCUTCHEON SPRING	
89796—1949 to 5306
8 GLASS LOWER CHANNEL WEATHERSTRIP	
1248073—1949-5058
1246838—1951-5271

1477506—1953, conv. (right*)..	.84
1491932—1953, spec. cpe. (right*)84
9 WINDOW GLASS UPPER WEATHERSTRIP	
1248139—1949-50	1.21
1380195—1951-52 (right*) ...	3.75
1334675—1953, conv. (right*)..	4.75

Door Assembly

Convertible Coupe and Roadster

See Fig. 11

1 DOOR (Less glass, trim and hardware)	
1249762—1949, conv. cpe. (right*)	64.93
1301480—1949, roadster (right*)	64.07
1334322—1950, roadster (right and left)	64.93
1342572—1950, conv. cpe. (right*)	64.93
1348868—1951-52, roadster (right*)	64.93
1348868—1951-52, conv. cpe. (right*)	64.93
1431320—1953, conv. (right*) ..	61.75
1 DOOR (Includes hardware, trim and glass)	
1365057—1950, conv. cpe. (right*)	212.47
1386037—1951-52, roadster (right*)	122.29
1386043—1951-52, conv. cpe. (right*)	212.47
2 UPPER DOOR HINGE	
1244180—1949 (right*)	4.77
1333271—1950 (right*)	4.77
1334983—1951-52 (right*) ...	4.77
1475834—1953, D44, conv. (right*)	P.O.A.
1457912—1953, D48, conv. (right*)	P.O.A.
3 LOWER DOOR HINGE	
1244187—1949 (right*)	4.77
1307509—1950 (right*)	4.77
1334985—1951-52 (right*) ...	4.77
1491054—1953, D48, conv. (right*)	4.77
4 WINDOW REGULATOR	
1249650—1949 to 52, conv. cpe., roadster (right*)	4.16
1457206—1953, conv. (right*)..	6.75
5 WINDOW REGULATOR ARM AND PIVOT	
1245630—1949 to 52, conv. cpe., roadster (right*)	1.84
6 DOOR WINDOW FRAME LOWER CHANNEL	
1246834—1949-50, conv. cpe. (right*)	4.77
1332295—1950, roadster (right*)	4.77
1380200—1951-52, conv. cpe., roadster (right*)	4.77
1458194—1953, conv. (right*)..	4.77
7 DOOR LOCK	
1242693—1949 to 52, conv. cpe. and roadster (right*)	4.77
1458152—1953, conv. (right*)..	4.77
8 DOOR LOCK REMOTE CONTROL	
1296698—1949 to 52, conv. cpe., roadster (right*)	1.84
1432778—1953, conv. (right*)..	2.39
9 LOCK REMOTE CONTROL LINK	
1244139—1949 to 52, conv. cpe., roadster	1.84
1457696—1953, conv. (right*)..	2.39
10 DOOR GLASS REAR RUN	
1246990—1949	P.O.A.
1338780—1950 to 52, conv. cpe., roadster	P.O.A.
1457769—1953, conv.	P.O.A.

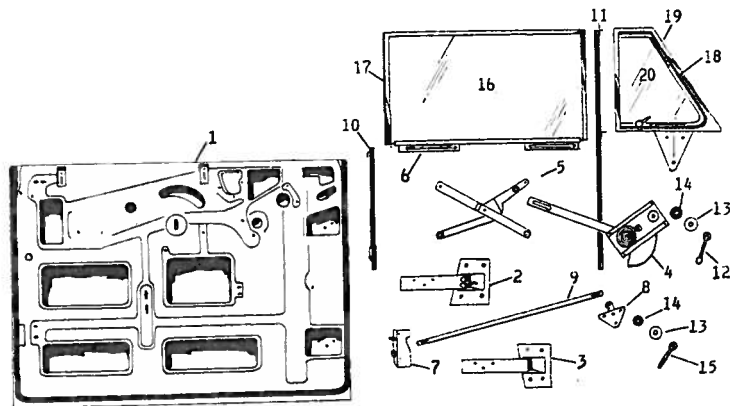

Fig. 11—Door Assembly, Convertible, Coupe and Roadster

* Opposite side one part number higher

BODY PARTS 1949 thru 1953 DODGE

ALL BODY STYLES

DOOR VENT WING DIVISION CHANNEL	
1246909—1949-50, conv. cpe...	1.15
1380360—1951-52, conv. cpe., roadster	1.23
1459534—1953, conv.	1.35
DOOR WINDOW REGULATOR HANDLE	
1296582—1949-50, conv. cpe...	1.84
1298148—1950 to 53, conv. cpe., roadster	2.39
REGULATOR HANDLE ESCUTCHEON	
1296570—1949-50, conv. cpe. . .	.74
1256038—1950 to 53, conv. cpe., roadster37
REGULATOR HANDLE SPRING	
89796—1949 to 5306
REMOTE CONTROL HANDLE	
981381—1949 to 53	1.10
987067—1953, D47, 48	1.10
DOOR GLASS	
1246836—1949, conv. cpe.	P.O.A.
1308760—1949 (plastic) roadster	16.29
1336553—1950, conv. cpe.	P.O.A.
1303821—1950, roadster	P.O.A.
1373930—1951-52, roadster ...	P.O.A.
1381298—1951-52, conv. cpe. . .	P.O.A.
1433359—1953, conv.	P.O.A.
DOOR GLASS FRAME	
1246832—1949-50, conv. cpe. (right*)	20.43
1373928—1951-52, roadster (right*)	19.70
1380206—1951-52, conv. cpe. (right*)	14.97
1433737—1953, conv. up.	4.05
1433630—1953, conv. (right*)
DOOR VENTILATOR ASSY.	
1308787—1949, roadster (right*)	23.76
1246958—1949-50, conv. cpe. (right*)	25.96

1342472—1950, roadster (right*)	25.96
1380342—1951-52, conv. cpe., roadster (right*)	26.80
1477744—1953, conv. (right*)..	17.95
19 DOOR VENTILATOR WING GLASS FRAME	
1342476—1949-50, D30-33-34, conv. cpe., roadster (right*)	9.41
1380350—1951-52, D41-42, conv. cpe., roadster (right*)	9.41
1477704—1953, conv. (right*)..	5.05
20 DOOR VENTILATOR WING GLASS	
1246981—1949, conv. cpe.	P.O.A.
1342480—1950 to 52, conv. cpe.	P.O.A.
1380490—1951-52, roadster ...	P.O.A.
1457272—1953, conv.	P.O.A.
DOOR VENTILATOR WING HANDLE	
895029—1949, conv. cpe. (right*)79
1303851—1950, conv. cpe. (right*)84
1332598—1951-52 (right*)84
1385505—1951-52 (right*)84
1490430—1953, conv. (right*)..	.84

Folding Top

*Convertible Coupe and Roadster
See Fig. 12*

FOLDING TOP FRAME	
1306578—1949 to 52, roadster.	99.34
FOLDING TOP TRIMMED, ALL TRIMS	
1291406—1950 to 52, conv. cpe.	P.O.A.
1 FOLDING TOP HEADER FRONT WEATHERSTRIP	
1246600—1949 to 52, conv. cpe. and roadster	4.26
1457039—1953, conv.	48.75

1 FOLDING TOP WINDSHIELD REAR HEADER WEATHER-STRIP	
1246601—1949 to 52, conv. cpe. and roadster	1.27
1477754—1953, conv.	2.85
2 TOP HEADER DOWEL	
1246438—1949-50, conv. cpe. (right end*)	2.37
1246517—1949-50, conv. cpe., center	2.37
1298478—1949-50, roadster ...	1.27
1491798—1953, conv. (right*)..	2.37
1246517—1953, conv. (center) .	2.37
3 TOP FRONT SIDE RAIL	
1245732—1950 to 52, conv. cpe. (right*)	7.20
1433106—1953, conv. (right*)..	8.00
4 TOP LOCKING SHAFT HANDLE SPRING	
1246432—1949-50; 1953, conv. cpe.06
5 TOP LOCKING SHAFT HANDLE ESCUTCHEON	
1246431—1949-50; 1953, conv. cpe.42
6 TOP LOCKING SHAFT HANDLE	
1246428—1949 to 5385
7 TOP NO. 1 BOW, W/SIDE RAIL CONTROL LINK	
1249172—1949 to 52, conv. cpe. (right*)	8.30
1457886—1953, conv. (right*)..	7.65
8 TOP SIDE REAR RAIL	
1245705—1950 to 52, conv. cpe. (right*)	7.72
143390—1953, conv. (right*)..	9.75
9 TOP MAIN CONTROL PROP	
1246335—1949 to 52, conv. cpe.	1.69
1433287—1953, conv.	1.70
10 TOP FOLDING PILLAR	
1246284—1949 to 52, conv. cpe. (right*)	20.45
1433372—1953, conv. (right*)..	19.50
11 TOP POWER GUIDE LINK	
1246340—1950, conv. cpe. (right*)	2.63
1347790—1951-52, white, conv. cpe. (right*)	2.84
1347724—1951-52, fin., conv. cpe. (right*)	3.04
1457886—1953, conv. (right*)..	7.65
12 TOP NO. 1 BOW	
1245261—1949 to 52, conv. cpe.	3.16
1306524—1950 to 52, roadster.	13.51
1433327—1953, conv.	2.80
13 TOP NO. 2 BOW	
1245287—1949 to 52, conv. cpe.	3.16
1298594—1950 to 52, roadster.	17.39
1433279—1953, conv.	2.80
14 TOP REAR BOW	
1246436—1950 to 52, conv. cpe.	8.30
1433290—1953, conv.	9.15

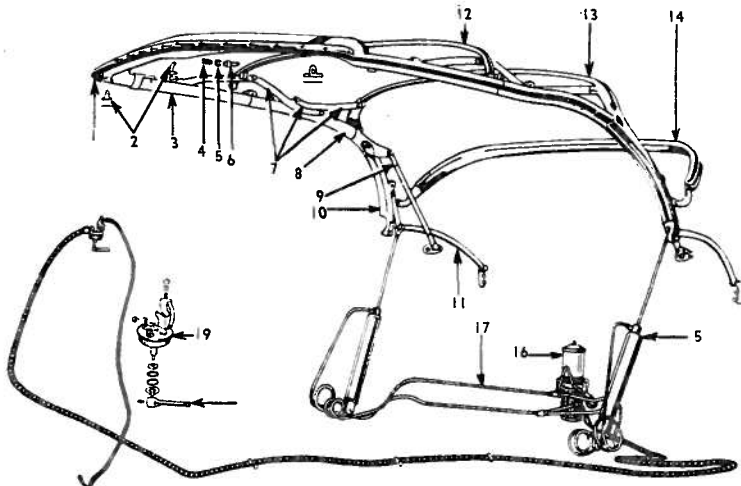

Fig. 12—Folding Top Assembly

* Opposite side one part number higher

continued

DODGE 1949 thru 1953 BODY PARTS

ALL BODY STYLES

Folding Top—continued

15 TOP OPERATING CYLINDER, INCLUDES YOKE	
1249516—1949 to 53, conv. cpe.	14.34
15 CYLINDER MOUNTING BRACKET	
1249423—1949 to 52, conv. cpe.	1.84
16 TOP LIFT MOTOR W/PUMP ASSY.	
1297763—1949 to 52, conv. cpe.	49.32
16 TOP LIFT MOTOR W/O PUMP	
1300526—1949 to 52, conv. cpe.	27.65
1491035—1953, conv.	26.34
17 TOP OPERATING CYLINDER TUBE	
861846—1949 (right)	1.20
861849—1949 (left)	1.48
861849—1950 to 52 (right)	1.48
861845—1950 to 52 (left)	1.05
18 TOP CONTROL SWITCH KNOB	
1300750—1949 to 53	.84
19 TOP CONTROL SWITCH	
911533—1949	4.36
1345455—1951 to 53	4.58

Frame Assembly

See Fig. 13

1 FRAME ASSY.	
1323118—1950-50, exc. roadster	122.75
1323120—1949-50, roadster	163.09
1311502—1949, sta. wag.	119.73
1323114—1949-50, club cpe. and 4 dr. sed.	125.69
1139696—1949-50, 7 sed.	249.21
1138478—1949-50, conv cpe.	166.58
1323157—1950, sta. wag.	119.73
1324674—1950 to 52, spec. club cpe.	166.58
1323118—1951-52, 2 dr. sed. and 3 cpe.	122.75

1323120—1951-52, roadster	163.09
1323114—1951-52, 4 dr. sed. and club cpe.	125.69
1323123—1951-52, conv. cpe.	166.58
1328069—1951-52, 8 sed.	249.21
1323157—1951-52, est. wag.	119.73
1403109—1953, D46, sub.	110.31
1403104—1953, D46	142.25
1403053—1953, D44	142.25
1405747—1953, D48, conv.	172.76
1405746—1953, D48, sub.	131.09
1405746—1953, D48, spec. cpe.	131.09
2 FRAME FRONT CROSS MEMBER	
1141209—1949 to 52	30.17
1323250—1953	2.05
3 UPPER CONTROL ARM SUPPORT	
1312042—1949 to 52	2.89
1323249—1953	2.05
4 BODY BRACKET NO. 1	
1312306—1949 to 52, exc. tw. sed. (right*)	3.16
1402012—1953, D47, 48	2.34
1403077—1953, D44, 46	2.49
5 BRACKET NO. 2	
1141379—1949 to 52, roadster and conv. cpe.	2.99
1137149—1949 to 52, exc. roadster	1.32
1138432—1949 to 52, 7-8 sed.	1.94
1137149—1949, exc. 7 sed. and conv. cpe.	1.32
1402009—1953, all	1.15
6 BRACKET NO. 3	
1139443—1949 to 52, roadster.	2.63
1313324—1949 to 52, 7-8 sed.	3.68
1137152—1949 to 52, 4 dr. sed., cl. cpe., sta. and est. wag.	1.32
1402002—1953, all	1.15
7 BRACKET NO. 4	
1311488—1949 to 52, 2-4 dr. sed., conv. cpe., cl. cpe., 7 sed., sta. and est. wag.	2.05
1311493—1949 to 52, exc. roadster	1.15
1402002—1953, all	1.15

8 FRAME REAR SPRING FRONT HANGER	
1124575—1949 to 52 (right*)	1
1485125—1953, all	
9 BRACKET NO. 5	
1311485—1949 to 52, 4 dr. sed., cl. cpe., sta. and est. wag.	1
1313327—1950 to 52, 7-8 sed.	2
1141382—1949 to 52, roadster, conv. cpe., spec. club cpe. (right*)	2
BRACKET NO. 6	
1313330—1950 to 52, 7-8 sed.	3
10 FRAME REAR SPRING REAR HANGER	
1137076—1949 to 52 (right*)	1
1403207—1953, all	1
11 REAR CROSS MEMBER	
1140339—1949 to 52, exc. 7 sed., conv. cpe., sta. and est. wag.	4
1140327—1949 to 52, 7-8 sed.	6
1141753—1949 to 52, conv. cpe., spec. cl. cpe., sta. and est. wag.	4
1311497—1949-50, sta. wag.	4
1405712—1953, all	4
12 INTERMEDIATE CROSS MEMBER	
1141736—1949 to 52, exc. 7-8 sed.	6
1140328—1949 to 52, 7-8 sed.	9
1401995—1953, D48, exc. sub.	6
1403141—1953, sub.	7
13 ENGINE REAR SUPPORT CROSS MEMBER	
1137060—1949 to 52, exc. 7-8 sed.	6
1137105—1949 to 52, 7-8 sed.	7
1330461—1953, D47	9
1403090—1953, D46	9
1403068—1953, D44, 48	9
14 FRONT CROSS MEMBER BRACE	
1137071—1949 to 53	

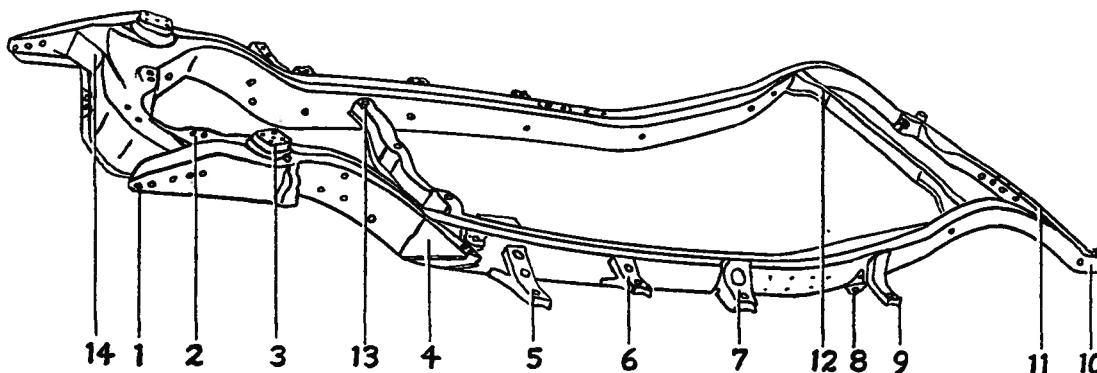

Fig. 13—Frame Assembly

* Opposite side one part number higher

BODY PARTS 1949 thru 1953 DODGE

ALL BODY STYLES

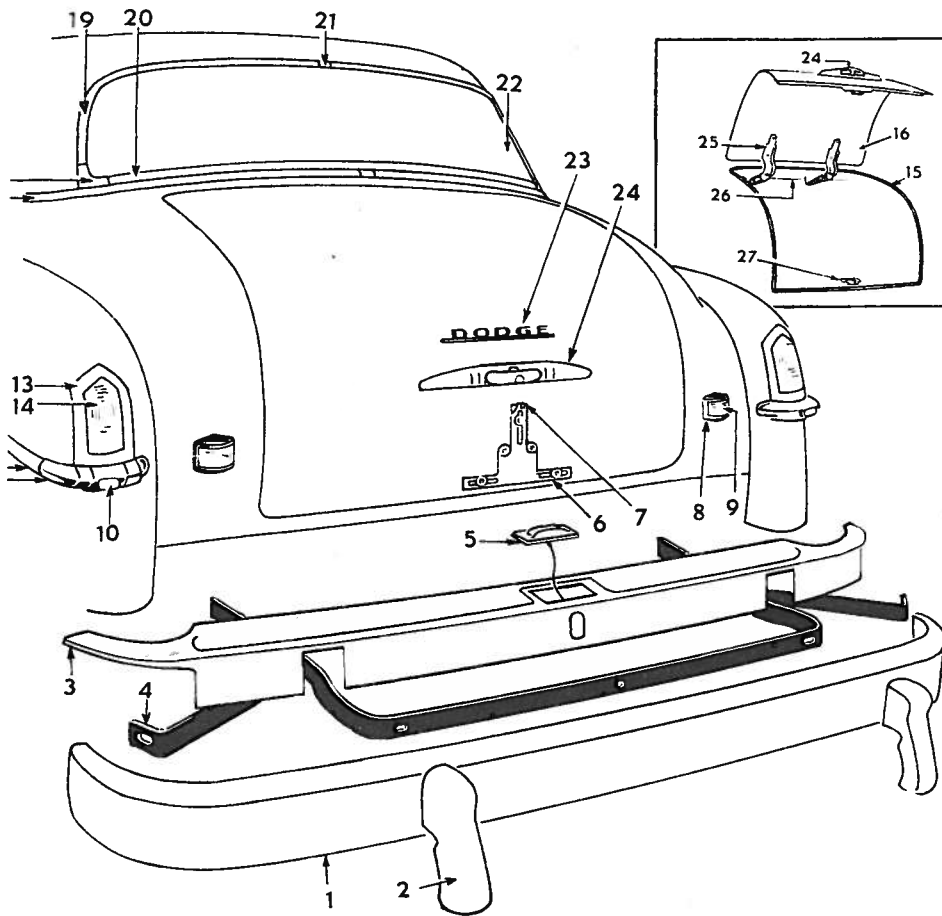

Fig. 14—Rear End Sheet Metal (1950 Illustrated)

Rear End

See Fig. 14

REAR BUMPER FACE BAR

1141824—1949, 7 sed.	40.64
1312497—1949, stn. wgn.	
(right*)	21.40
1137698—1949-50, 2 dr. sed., club cpe., conv. cpe., 4 dr. sed.	42.75
1319565—1950, exc. 2 dr. sed., 7 sed., stn. wgn.	42.75
1319636—1950, 7 sed. and 7 sub.	46.57
1319153—1950, stn. wgn.	
(right*)	22.50
1319110—1950, stn. wgn., center	39.23
1321725—1951-52, exc. 2 dr. sed., 8 sed., est. wgn.	42.75
1324011—1951-52, 2 dr. sed. ...	42.75
1326343—1951-52, 8 sed.	
(right*)	19.87
1326345—1951-52, 8 sed., center	8.75
1324042—1951-52, est. wgn. ...	42.75
1405241—1953, sub.	30.50
1402888—1953, D44, 46	42.75
1329457—1953, D48, exc. sub...	34.95

2 BUMPER BUFFER PLATE

1141806—1949, exc. 7 sed., stn. wgn. (right*)	7.85
1142188—1949, 7 sed., stn. wgn.	
(right*)	6.88
1319586—1950, exc. 7 sed., stn. wgn. (right*)	6.35
1319584—1950, 7 sed. (right*)	6.95
1319284—1950, 7 sed., stn. wgn.	
(right*)	8.83
1324628—1951-52, exc. est. wgn.	
(right*)	6.63
1326661—1951-52, est. wgn.	
(right*)	7.75
1483149—1953, exc. sub.	
(right*)	6.35
1405253—1953, sub.	14.50

3 REAR BUMPER STONE DEFLECTOR

1302201—1949, exc. 7 sed., stn. wgn.	8.55
1314109—1949, sta. wgn.	
(right*)	12.00
1333833—1950, 3 cpe., roadster	8.55
1333970—1950, 2 dr. sed.	8.55
1333833—1950, 4 dr. sed., club cpe., spec. club cpe.	8.55

1341083—1950, 7 sed.	12.50
1321699—1950, stn. wgn.	12.00
1324666—1950, est. wgn.	12.00
1364879—1951-52, 2 dr. sed. ...	8.55
1364966—1951-52, D41-42, exc. 2 dr. sed., 8 sed., est. wgn.	8.55
1368480—1951-52, 8 sed.	12.50
1364973—1951-52, est. wgn. ...	12.50
1402896—1953, D48, exc. sub...	7.65
1407799—1953, sub.	13.75
1476413—1953, D44, 46 (right*)	4.10

3 REAR STONE DEFLECTOR SHIM

313073—1949 to 52, sold by the foot11
1255778—1951 to 52, rubber, sold by the inch02

4 REAR BUMPER FACE BAR SUPPORT

1316432—1949, exc. 2 dr. sed., 7 sed. (right*)	5.50
1316440—1949-50, 2 dr. sed.	
(right*)	5.50
1141822—1949, 7 sed.	12.72
1312499—1949, stn. wgn.	
(right*)	13.82
1316438—1950, 2 dr. sed., center	3.68
1319561—1950, exc. 2 dr. sed., 7 sed., stn. and est. wgn. ...	14.75
1319632—1950, 7 sed. and 7 sub.	15.57
1402918—1951-52 (right*) ...	5.25
1402924—1951-52, 2 dr. sed.	
(right*)	4.73
1326346—1951-52, 8 sed.	16.85
1324043—1951-52, est. wgn. ...	15.72
1403864—1953, D48, exc. sub.	
(right*)	4.53
1405249—1953, sub.	11.50
1403846—1953, D44, 46 (right*)	5.50

5 LICENSE LAMP LENS BEZEL

1244895—1949, 4 dr. sed., club cpe. and conv. cpe.	1.94
1244779—1950 to 52, D33-34-41-42	2.15

5 LICENSE LAMP LENS

1244898—1949, 4 dr. sed., club cpe. and conv. cpe.59
1257456—1949, stn. wgn.70
1244749—1950 to 52, D33-34-41-4262
1345885—1953, D47, 48, sub.48

5 LICENSE LAMP LENS GASKET

1244902—1949, D29-3017
1257457—1949, stn. wgn.11
1257677—1951-52, D41-4238

6 REAR LICENSE MOUNTING BRACKET

1302836—1949, D29-3042
1257460—1949, stn. wgn.68
1339849—1950 to 52, D33-34-41-4268
1383208—1953, D47, 4847

continued

* Opposite side one part number higher

DODGE 1949 thru 1953 BODY PARTS**ALL BODY STYLES****Rear End—continued**

7 REAR LICENSE BRACKET CLAMP	
1244698—1949, D29-3010
8 BACK UP LAMP BEZEL	
1345105—1950 to 52, 2 dr. sed. (right*)	2.85
1343367—1950 to 52, exc. 2 dr. sed., 7 sed. and stn. wgn. (right*)	2.56
1343599—1950, 7 sed. (right*)	2.56
1345620—1950, est. and stn. wgn. (right*)	2.95
1383486—1951-52, est. wgn. (right*)	4.45
8 BACK UP LAMP LENS GASKET	
1343363—1950 to 52, exc. est. wgn.22
1343341—1951-52, est. wgn.22
9 BACK UP LAMP LENS	
1343364—1950 to 52, exc. stn. wgn. and est. wgn.71
1343343—1951-52, est. wgn.71
10 TAIL LAMP BUTTON REFLECTOR	
1235512—1949, D2921
1300840—1949, 4 dr. sed., club cpe. and conv. cpe.74
1300500—1950 to 5290
1253173—1950 to 52, reflector.21
11 REAR FENDER MOLDING	
1252833—1949, exc. 7 sed. and stn. wgn. (right*)	3.74
1253716—1949, 7 sed. and stn. wgn. (right*)	12.90
1333837—1950, D33-34, exc. 2 dr. sed. and stn. wgn.	4.11
1333935—1950 to 52, 2 dr. sed.	4.11
1364970—1951-52, D41, 3 cpe., roadster, D42, 4 dr. sed. (right*)	4.46
1371997—1951-52, D41, roadster, D42, 4 dr. and est. wgn. (right*)	4.46
1476500—1953, 2 & 4 dr., cl. cpe. (right*)	5.50
1491802—1953, conv., spec. cpe. (right*)	4.25
1496778—1953, sub. (right*) ..	3.95
12 REAR FENDER MOLDING EXTENSION	
1340356—1950, D33-34, exc. 2 dr. sed., stn. and est. wgn. (right*)	4.52
1253716—1950, stn. wgn. (right*)	12.90
1369869—1951-52, D41-42 (right*)	4.58
1364632—1951-52, est. wgn. ...	5.59

13 TAIL LAMP SHELL	
1257308—1949, 2 dr. sed. (right*)	5.29
1244878—1949, 3 cpe. and roadster (right*)	2.63
1300898—1949, conv. cpe. (right*)	9.67
13 TAIL LAMP BASE	
1300547—1949, 4 dr. sed. and club cpe. (right*)	10.20
13 TAIL AND STOP LAMP BEZEL	
1297713—1950, stn. wgn.	2.48
1343181—1950 to 52, 2 dr. sed. (right*)	6.70
1340351—1950 to 52, D33-34-41-42 (right*)	3.55
1436503—1951-52, roadster and 4 dr. sed. (right*)	6.70
1345770—1951-52, est. wgn. (right*)	3.95
1479202—1953	5.10
14 TAIL LAMP LENS	
1244881—1949, 3 cpe. and roadster92
1257323—1949 to 1951-52, D29-41, 2 dr. sed.95
1300555—1949, 4 dr. sed., club cpe. and conv. cpe. (right*) ..	1.49
1340191—1950 to 52, D33-41 (right*)	1.12
1340347—1950 to 52, D33-34-41-42 (right*)	1.26
1297714—1950, stn. wgn.95
1345758—1951-52, est. wgn. ...	1.05
1439899—1953, exc. sub.60
1473343—1953, sub.55
14 TAIL LAMP LENS GASKET	
1257324—1949 to 1951-52, 2 dr. sed.11
1253147—1949, 3 cpe. and roadster11
1300927—1949, 4 dr. sed., club cpe. and conv. cpe.28
1340499—1950 to 52, 2 dr. sed.15
1340353—1950 to 52, D33-34-41-4245
1297715—1950, D34, stn. wgn.11
1345760—1951-52, est. wgn.45
1439893—1953, exc. sub.30
1473344—1953, sub.
FUEL TANK FILLER CAP	
384982—1949 to 5280
1404389—1953	1.45
15 LUGGAGE COMPARTMENT WEATHERSTRIP	
1242254—1949 to 52, 3 cpe. and roadster	5.78
1242298—1949 to 52, 2 dr. sed.	4.41
1244478—1949 to 52, 4 dr. sed., club cpe., conv. cpe., spec. club cpe., carry-all sed.	5.15
1305451—1950 to 52, 7-8 sed. and limo., sub. sed.	5.15
1432662—1953, D48, all	5.85
1475214—1953, D44, 46	5.92

16 LUGGAGE COMPARTMENT LID	
1242236—1949, 2 dr. sed.	37.
1242237—1949, 3 cpe. and roadster	43.
1333724—1949, 4 dr. sed. and club cpe.	40.
1303163—1949, conv. cpe.	40.
1331858—1950, 2 dr. sed.	37.
1331859—1950 to 52, 3 cpe. and roadster	43.
1331856—1950, 4 dr. sed., club cpe., conv. cpe., spec. club cpe.	40.
1341097—1950 to 52, 7-8 sed. and limo.	40.
1372260—1951-52, 2 dr. sed. ...	36.
1331856—1951-52, 4 dr. sed., club cpe., conv. cpe., spec. club cpe.	40.
1528033—1953, D44, 46	43.
1527998—1953, D48	42.
17 REAR QUARTER BELT MOLDING	
1256170—1949 to 52, 4 dr. sed., carry-all sed. (right*)	4.
1256174—1949 to 52, club cpe. (right*)	4.
1242411—1949 to 52, 3 cpe. (right*)	4.
1242415—1949, 2 dr. sed. (right*)	2.
1303284—1949 to 52, conv. cpe., rear (right*)	4.
1303316—1949, conv. cpe., front (right*)	5.
1242415—1950 to 52, 2 dr. sed. (right*)	4.
1336586—1950, conv. cpe., front (right*)	3.
1342462—1950, spec. club cpe., front (right*)	4.
1305130—1950 to 52, 7-8 sed. (right*)	4.
1348724—1950 to 52, spec. club cpe., upper	1.
1380712—1952, spec. club cpe., front (right*)	5.
1370967—1952, est. wgn., lower corner, upper	1.
1370968—1952, est. wgn., lower corner, lower	1.
1364557—1952, est. wgn., rear w/end clip (right*)	3.
18 REAR WINDOW LOWER CORNER	
1364025—1950, 4 dr. sed. and club cpe.	1.
1338683—1950, 3 cpe.9
1334873—1951-52, D41, 3 cpe. (right*)9
19 REAR WINDOW UPPER MOLDING	
1256333—1949, 4 dr. sed. and club cpe.	3.
1298555—1949, 2 dr. sed.	2.
1336067—1950, 3 cpe. (right*) ..	1.

* Opposite side one part number higher

BODY PARTS 1949 thru 1953 DODGE

ALL BODY STYLES

1334898—1950, 4 dr. sed., club cpe. (right*)	2.16	1371079—1951-52 (side clip), 4 dr. sed., club cpe. (right*)	.27	24 LUGGAGE LID LOCK HANDLE W/BASE ORNAMENT	
1305178—1950 to 52, 7-8 sed...	7.20	1364420—1951-52 (clip), 3 cpe. and club cpe.	.38	1490042—1950 to 52, 4 dr. sed., 3 cpe., club cpe., conv. cpe., roadster, spec. club cpe. ...	10.75
1370834—1951-52, 2 dr. sed. ..	2.10	1491801—1953, spec. cpe. low. cor.	.45	1490097—1950 to 52, 2 dr. sed.	10.75
1491080—1953, spec. cpe. up. (right*)	1.95	1475455—1953, 2 & 4 dr. sed., cl. cpe. & spec. cpe. (right*)	.70	1347834—1950 to 52, 7-8 sed..	9.00
1474917—1953, 4 dr. sed. (right*)	3.45			24 LUGGAGE LID HANDLE	
1364428—1951-52, 3 cpe. (right*)	1.94	22 REAR WINDOW GLASS		1332712—1951-52, 2 dr. sed. ..	3.09
1366342—1951-52, 4 dr. sed. ..	4.86	1240326—1949, 4 dr. sed.	P.O.A.	1332713—1951-52, 4 dr. sed., 3 cpe., club cpe., conv. cpe., roadster, spec. club cpe. ...	3.09
1372033—1951-52, club cpe. (right*)	3.52	1242020—1949, 3 cpe.	P.O.A.	1347835—1951-52, 8 sed.	3.09
1342024—1950 to 52, spec. club cpe., upper center	3.10	1240447—1949, club cpe.	P.O.A.		
		1242379—1949 to 52, 2 dr. sed.	P.O.A.	25 LUGGAGE COMPARTMENT LID HINGE	
REAR WINDOW LOWER MOLDING		1255122—1949, stn. wgn., upper tail gate	P.O.A.	1303188—1949, conv. cpe. (right*)	4.99
1305179—1950 to 52, 7-8 sed...	3.47	1336041—1950 to 52, 3 cpe. ...	P.O.A.	905339—1949 to 1951-52, 3 cpe.	1.37
1342194—1950 to 52, spec. club cpe., lower center	3.10	1333684—1950, 4 dr. sed.	P.O.A.	1257068—1949, 4 dr. sed., 2 dr. sed., club cpe.	2.05
1342268—1950 to 52, spec. club cpe., lower end (right*)	2.37	1333624—1950, club cpe.	P.O.A.	1333422—1950, 2 dr. sed.	2.37
1364430—1951-52, 3 cpe.	2.37	1304486—1950 to 52, 7-8 sed. and sub. sed.	P.O.A.	1298443—1950, roadster (w/link) (right*)	2.47
1315315—1950, 3 cpe.	3.79	1334362—1950, side glass, spec. club cpe. (right*)	P.O.A.	1241466—1950 to 52, 4 dr. sed. and spec. club cpe.	2.05
1315316—1950, 4 dr. sed. and club cpe.	5.73	1342182—1950 to 52, center glass, spec. club cpe.	P.O.A.	1257068—1950 to 52, club cpe..	2.05
1439000—1953, 2 dr., cl. cpe. (right*)	2.92	1331354—1950 to 52, folding top curtain light, conv. cpe., roadster	14.35	1341566—1950 to 52, conv. cpe.	5.36
1491804—1953, spec. cpe.	1.95	1369277—1951-52, 2 dr. sed. ...	P.O.A.	1336455—1950 to 52, 7-8 sed. (w/bracket)	4.58
		1366339—1951-52, 4 dr. sed. and carry-all sed.	P.O.A.	1333422—1951-52, 2 dr. sed. (w/link, lever and arm) (left)	2.37
REAR WINDOW GLASS WEATHERSTRIP		1366369—1951-52, club cpe. ...	P.O.A.	1242111—1951-52, roadster ...	1.57
1242096—1949, 3 cpe.	5.88	1342180—1951-52, spec. club cpe. (right*)	P.O.A.	892517—1951-52, 8 sed. and sub. sed.	1.37
1244039—1949, club cpe.	4.26	1364066—1951-52, est. wgn. (upper tail gate) early	P.O.A.	1457232—1953, exc. conv. (right*)	5.36
1254627—1949, 4 dr. sed.	3.68	1371867—1951-52, est. wgn. (upper tail gate) late	P.O.A.	1458058—1953, conv. (right*)	5.43
1242299—1949-50, 2 dr. sed. ...	6.47	1372153—1953, 4 dr. sed.			
1336032—1950, 3 cpe.	4.04	1497915—1953, conv.			
1333683—1950, club cpe.	4.26	1458126—1953, spec. cpe. (right*)			
1333996—1950, 4 dr. sed.	4.26	1458123—1953, spec. cpe. (center*)			
1342019—1950 to 52, spec. club cpe.	12.72			26 LUGGAGE COMPARTMENT LID HINGE SPRING	
1371751—1951-52, 2 dr. sed. ...	10.36	23 LUGGAGE COMPARTMENT LID NAME PLATE		1306710—1949 to 52, 2 dr. sed., 3 cpe. (includes guide*)	3.16
1364431—1951-52, 3 cpe.	4.78	1254678—1949, 4 dr. sed., club cpe., conv. cpe.	1.48	1239087—1949 to 52, club cpe.	2.94
1366347—1951-52, 4 dr. sed. and club cpe.	5.93	1256574—1949, 3 cpe. and roadster	4.22	1242717—1949 to 52, 4 dr. sed.	2.94
1304487—1951-52, 8 sed. and sub. sed.	3.68	1256575—1949, 2 dr. sed.	4.22	1343017—1950 to 52, 2 dr. sed. (guide, w/spring)	2.94
1372427—1953, 4 dr. sed.	7.58	1331627—1950, 2 dr. sed.	1.60	1306712—1950, roadster (guide, w/spring)	3.94
1438953—1953, 2 dr. sed., cl. cpe.	8.12	1331627—1950, all exc. 2 dr. sed.	1.60	1244816—1950, 4 dr. sed. and spec. club cpe. (guard)	.42
		1331627—1951-52, all	1.60	1384111—1951-52, 4 dr. sed. and 8 sed. (guide, w/spring)	2.94
REAR WINDOW DIVISION BAR		1475917—1953, D44, 48 (V-8).	1.10	1342376—1951-52, 8 sed. and sub. sed. (guide, w/spring)	3.16
1348710—1951-52, spec. club cpe.	1.15	1475693—1953, D44, 48 (V-8 & Gyro-Matic)	1.35	1342705—1951-52, spec. club cpe. (guide, w/spring)	2.94
		1475694—1953, D44, 48 (V-8 & Gyro-Torque)	1.35		
REAR WINDOW OUTSIDE MOLDING JOINT CLIP AND COVER		1475698—1953, D46 (Gyro-Matic)	1.10	27 LUGGAGE LID LOCK CATCH	
1256334—1949, clip, 4 dr. sed. and 3 cpe.38			1299663—1949 to 52	.42
1334163—1950, clip, 4 dr. sed., 3 cpe., club cpe.32	24 LUGGAGE COMPARTMENT LID HANDLE		1490321—1953	.42
1305180—1950 to 52, cover, 7-8 sed. (right*)	.95	1244887—1949, 4 dr. sed., 3 cpe., club cpe., conv. cpe., roadster	2.13		
1342272—1950 to 52, lower corner cover, spec. club cpe.	.68	1257300—1949, 2 dr. sed.	2.13	27 LUGGAGE COMPARTMENT LOCK CYL. AND KEYS	
1371848—1951-52 (clip), 2 dr. sed.38	1302614—1949, 7 sed.	2.13	1316201—1949	2.11
				1331799—1950	2.14
				1332805—1951-52, exc. 2 dr. sed.	2.11
				1455721—1953, all	3.25

* Opposite side one part number higher

DODGE 1949 thru 1953 BODY PARTS

ALL BODY STYLES

Front Suspension

See Fig. 15

1 BUSHING DUST SEAL	
867152—1949 to 52, exc. 7-8 sed., sta. wag., est. wag. 1953	.11
696092—1949 to 52, 7-8 sed., sta. wag., est. wag.11
2 UPPER CONTROL ARM PIVOT BAR	
867150—1949 to 52, exc. 7-8 sed., sta. wag., est. wag. 1953	2.50
853284—1949 to 52, 7-8 sed., sta. wag., est. wag.	2.92
3 UPPER CONTROL ARM	
862669—1949-50, exc. 7 sed., sta. wag.	7.58
862775—1949-50, 7 sed., sta. wag.	9.46
1322175—1951-52, exc. 8 sed., est. wag. 1953	7.58
1319787—1951-52, 8 sed., est. wag.	9.57
4 UPPER CONTROL ARM PIVOT BAR BUSHING	
1141150—1949 to 52, exc. 7-8 sed., sta. wag., est. wag. 1953	.50
1141148—1949 to 52, 7-8 sed., sta. wag., est. wag.68
5 UPPER CONTROL ARM SHOCK ABSORBER STUD	
856197—1949, for 1137611 shock absorber	.66
861213—1949-50, 1" diam.71
1313945—1950, 1 3/8" diam.71
1319783—1951 to 53	.71
1322950—1951 to 53	.66

6 SHOCK ABSORBER INNER BUSHING RETAINER	
696150—1949, for 1137611 shock absorber	.04
1142547—1950	.04
1319555—1951 to 53	.04
6 SHOCK ABSORBER OUTER BUSHING RETAINER	
855071—1949, for 1137611 shock absorber	.10
1142548—1950	.04
1319554—1951 to 53	.04
7 SHOCK ABSORBER PIVOT BUSHING	
689062—1949	.10
1141099—1950	.20
1319902—1951 to 53	.20
8 SHOCK ABSORBER	
1311037—1949, 1" diam.	7.57
1326163—1949-50, 1" diam. ...	5.88
1316214—1950, 1 3/8" diam.	12.40
1321127—1951-52, 1" diam. ...	5.88
1326164—1951 to 53, 1 3/8" diam.	12.14
1326164—1953, 1" diam.	5.88
9 UPPER CONTROL ARM PIN AND NUT PACKAGE	
1241500—1949 to 52, exc. 7-8 sed., sta. wag., est. wag. 1953	1.05
1238409—1949 to 52, 7-8 sed., sta. wag., est. wag.	1.37
10 UPPER CONTROL ARM BUMPER	
861212—1949-50	.83
1322128—1951-52	.17
1402027—1953	.22

11 UPPER CONTROL ARM PIN BUSHING DUST SEAL	
1117380—1949-50, exc. 7-8 sed., sta. wag., est. wag.	
1117381—1949-50, 7-8 sed., sta. wag., est. wag.	
1322912—1951-52, exc. 8 sed. and est. wag. 1953	
1322911—1951-52, 8 sed. and est. wag.	
12 UPPER CONTROL ARM PIN BUSHING	
1064676—1949-50, 7 sed., sta. wag., est. wag.	1.
1321130—1949 to 52, exc. 7-8 sed. and est. wag. 1953	1.
1321131—1951-52, 8 sed. and est. wag.	1.
13 STEERING KNUCKLE SUPPORT	
856164—1949, exc. 7 sed. and sta. wag.	7.
1134150—1949, 7 sed. and sta. wag.	6.
1127955—1949, sta. wag. w/stud (right*)	10.
856164—1950, exc. 7 sed., sta. wag., est. wag. (right*)	7.
1127955—1950, 7 sed., sta. wag., est. wag. (right*)	10.
1322165—1951-52, exc. 8 sed., est. wag. (right*)	7.
1319788—1951-52, 8 sed., est. wag. (right*)	10.
1322165—1953 (right*)	7.
14 SHOCK ABSORBER LOWER STUD	
1404148—1949	
1313952—1950	
1404146—1951 to 53	
15 KING PIN LOCK PIN	
620371—1949 to 53	
16 LOWER CONTROL ARM PIN BUSHING PACKAGE	
1064677—1949 to 52, exc. 7-8 sed., sta. wag., est. wag.	1.
1064678—1949 to 52, 7-8 sed., sta. wag., est. wag.	1.
1241500—1953	1.0
17 LOWER CONTROL ARM PIN FRONT DUST SEAL	
1118883—1949 to 52, exc. 7-8 sed., sta. wag., est. wag. 1953	.1
1118884—1949 to 52, 7-8 sed., sta. wag., est. wag.1
17 LOWER CONTROL ARM PIN REAR DUST SEAL	
1118881—1949 to 52, exc. 7-8 sed., sta. wag., est. wag. 1953	.1
1118882—1949 to 52, 7-8 sed., sta. wag., est. wag.3
18 STEERING KNUCKLE THRUST BEARING	
626503—1949 to 52, exc. 7-8 sed., sta. wag., est. wag. 1953	.9
622407—1949 to 52, 7-8 sed., sta. wag., est. wag.	1.0

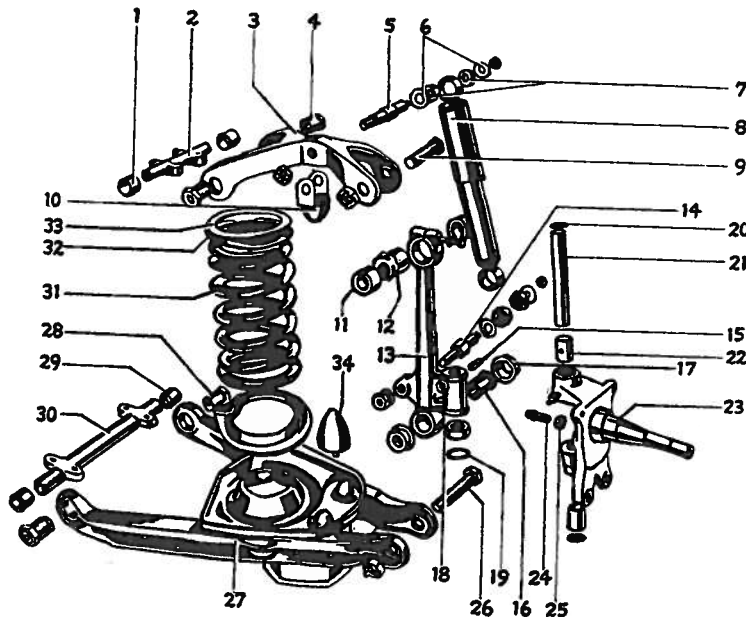

Fig. 15—Front Suspension Parts

* Opposite side one part number higher

BODY PARTS 1949 thru 1953 DODGE ALL BODY STYLES

STEERING KNUCKLE THRUST BEARING SHIM		22 STEERING KNUCKLE UPPER BEARING		29 LOWER CONTROL ARM BAR BUSHING DUST SEAL	
626871—1949 to 52 (.0035" thk.), exc. 7-8 sed., sta. wag., est. wag. 195304	681378—1949 to 52, exc. 7-8 sed., sta. wag., est. wag. 195376	696092—1949 to 52, exc. 7-8 sed., sta. wag., est. wag. 195311
626870—1949 to 52 (.010" thk.), exc. 7-8 sed., sta. wag., est. wag. 195304	857076—1949 to 52, 7-8 sed., sta. wag., est. wag.	1.04	854082—1949 to 52, 7-8 sed., sta. wag., est. wag.15
594804—1949 to 52 (.0085" thk.), 7-8 sed., sta. wag., est. wag. 195306	23 STEERING KNUCKLE (Includes bearing and bushing)		30 LOWER CONTROL ARM BAR	
KING PIN UPPER OIL SEAL PLUG		1311428—1949 to 52, exc. 7-8 sed., sta. wag., est. wag. (right*) 1953	12.09	852346—1949 to 52, exc. 7-8 sed., sta. wag., est. wag. 1953	3.24
117920—1949 to 52, exc. 7-8 sed., sta. wag., est. wag. 1953 ..	.10	866818—1949 to 52, 7-8 sed., sta. wag., est. wag. (right*) ..	14.51	853271—1949 to 52, 7-8 sed., sta. wag., est. wag.	4.05
179380—1949 to 52, 7-8 sed., sta. wag., est. wag. 1953 ..	.10	24 STEERING KNUCKLE STOP SCREW		31 FRONT SPRINGS	
KING PIN LOWER OIL SEAL PLUG		603342—1949 to 5310	864845—1949 to 53, cl. cpe., 4 dr. sed.	7.85
103894—1949 to 52, exc. 7-8 sed., sta. wag., est. wag. 1953 ..	.06	25 KNUCKLE STOP SCREW NUT		1139002—1949 to 52, heavy duty, cl. cpe., 4 dr. sed.	7.95
179380—1949 to 52, 7-8 sed., sta. wag., est. wag. 195310	120371—1949 to 5304	1141014—1949 to 53, heavy duty, conv. cpe., exc. 7-8 sed.	7.95
KING PIN SERVICE PACKAGE		26 LOWER CONTROL ARM PIN AND NUT PACKAGE		1318187—1949, conv. cpe.	7.95
947557—1949 to 52, D30-34-42, exc. 7-8 sed., sta. wag., est. wag. 1953	5.48	1241500—1949 to 52, exc. 7-8 sed., sta. wag., est. wag. 1953 ..	1.05	1140286—1949, 7 sed.	7.95
1311059—1949 to 52, D30-34-42, 7-8 sed., sta. wag., est. wag.	9.20	27 LOWER CONTROL ARM (w/spring seat)		1138943—1949 to 52, heavy duty, 7-8 sed.	8.45
933435—1949 to 52, D29-33-41 ..	4.42	1318178—1949, cl. cpe., 4 dr. sed. (right*)	6.51	1141014—1949 to 52, sta. wag., exc. 7-8 sed.	7.95
KING PIN		1313928—1949, cl. cpe., 4 dr. sed., 7-sed., sta. wag.83	32 SPRING UPPER SILENCER	
626975—1949 to 52 (.7955" O.D., 5 7/8" long), exc. 7-8 sed., sta. wag., est. wag. 1953 ..	.82	1318178—1950 to 53, 4 dr. sed., cl. cpe. (right*)	6.51	691144—1949-50, D30-33-3435
634036—1949 to 52 (.9365" O.D., 6 9/32" long), 7-8 sed. sta. wag., est. wag.	1.90	1313938—1949 to 53, conv. cpe., spec. cpe., 4 dr. sed., cl. cpe. (right*)	6.51	691144—1951-52, D42; 195335
STEERING KNUCKLE LOWER BUSHING		1313940—1949 to 52, 7-8 sed., sta. wag., est. wag. (right*) ..	8.00	32 SPRING LOWER SILENCER	
633672—1949 to 52, exc. 7-8 sed., sta. wag., est. wag. 1953 ..	.26	28 LOWER CONTROL ARM BAR BUSHING		1137550—1949 to 52, D30-34-42, heavy duty39
871297—1949 to 52, 7-8 sed., sta. wag., est. wag.77	1318246—1949, exc. 7 sed., sta. wag., est. wag.69	33 SPRING SPACER (Use on Driver's Side Only)	
		1324820—1949-50, 7 sed., sta. wag., est. wag.97	657770—194955
		1318246—1950 to 52, exc. 7-8 sed., sta. wag., est. wag. 1953 ..	.69	34 LOWER CONTROL ARM BUMPER	
		1324820—1951-52, 7 sed., sta. wag., est. wag.97	1137965—194983
				1319807—1950 to 52, exc. 7-8 sed., sta. wag., est. wag.83
				1313928—1950, 7 sed. sta. wag., est. wag.83
				1322966—1951-52, 8 sed., est. wag.87
				1404083—195355

STEERING GEOMETRY

1949 to 1953

ASTER: 1 degree negative to 1 degree positive.

AMBER: 1949-50 0 to 3/4 degree positive. 1951 to 53, -3/8° to +3/8°. Left side to be 1/4 to 1/2 degree greater than right side.

DE-IN: 0 to 1/16 inch.

TOE-OUT TURNS (TURNING RADIUS):
Outer Wheel 20 degrees. Inner Wheel 22 degrees. 1953, outer wheel 19 3/4 degrees. Inner wheel 20 degrees.

KING PIN INCLINATION: 1949-50 4 3/4 to 6 degrees. 1951-53 5 to 6 1/2 degrees.

ADJUSTMENTS

CASTER: Factory says not adjustable.

CAMBER: Is controlled by turning eccentric upper support bushings until correct adjustment is secured.

* Opposite side one part number higher

DODGE 1946 thru 1953 FRAMES

Sedan and Coupe Bodies

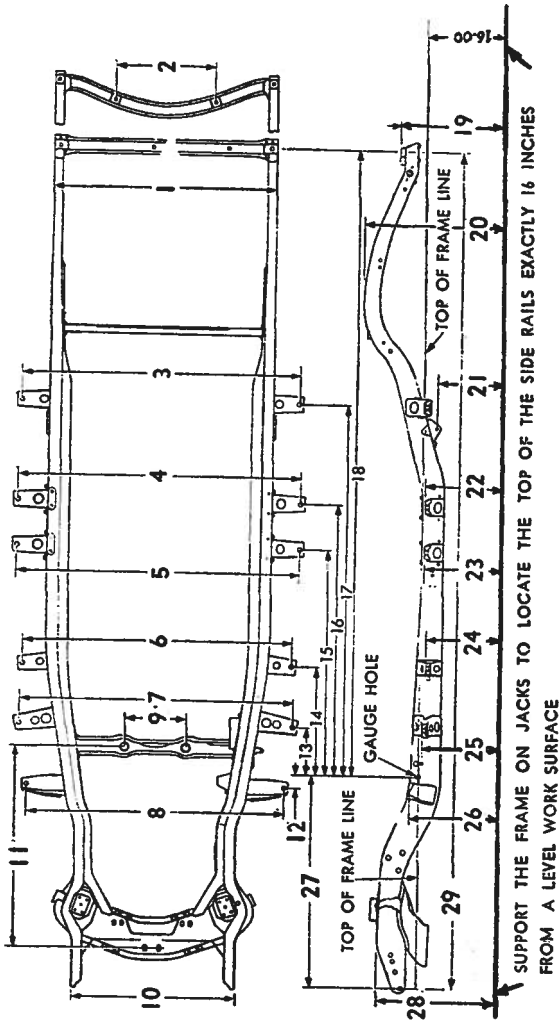

Model and Series	1	2	3	4	5	6	7	8	9	10	11	12	13	14	15	16	17	18	19	20	21	22	23	24	25	26	27	28	29	
1946-1948 4 dr. Sed. & Cpe.	48 1/4	50 1/2	52 1/16	50 1/2	50 1/2	50 1/2	40 7/32	34											20 7/8	26 1 3/16					38 31/32				169 3/4	
1946-1948 2 dr. Sedan	48 1/4	50 1/2	53 7/8	50 1/2	50 1/2	50 1/2	40 7/32	34											20 7/8	26 1 3/16					38 31/32				169 3/4	
1946-1948 7 pass. Sedan	48 1/4	50 1 9/32	53 7/8	50 3/4	50 3/4	50 3/4	40 5/8	34 3/32																						187 7/8
1949-1952 2 dr. Sed. & 3 pass. Coupe	43 1/2	53		54 1/4		55 5/8	50		12 3/8	31 3/4	45 5/64	41 7/32	7 1/16		57 7/8	67 1/4	120 5/8	21 1 3/32	28 9/32	115 7/64	141 1/32				143 1/8				165 5/8	
1949-1952 Club Cpe. & 4 dr. Sedan	43 1/2	53		54 1/4		52 55 5/8	50		12 3/8	31 3/4	45 35/64	41 7/32	7 1/16	25 1/2	47 7/8	75 5/8	129 1/8	21 1 3/32	28 9/32	115 7/64	141 1/32	141 1/32	149 1/8		143 1/8				174 1/8	
1949-1952 Stat. Wagon	43 1/2	20 53		54 1/4		52 55 5/8	50		12 3/8	31 3/4	45 35/64	41 7/32	7 1/16	25 1/2	47 7/8	75 5/8	129 1/8	21 1 3/32	28 9/32	115 7/64	141 1/32	141 1/32	141 1/16		143 1/8				174 1/8	
1949-1952 8 pass. Sedan	50 7/32	56 27/32	53 23/32	53 23/32	52 55 21/32	50 1/32	50 1/32		12 3/8	31 27/32	45 35/64	41 7/32	7 1/16	25 1/2	51 1/4	70 7/16	89 11/16	143 3/8	21 1 3/32	28 9/32	143 3/32	143 3/32	143 3/32	132 3/32		189 3/32				188 1/8
1953 4 dr. Sed. & Club Coupe	48 3/4	53 13/16	53 13/16	53 13/16		50 3/8	48		31 3/4		51 1/2	53 3/4			49 11/16	73 1/16			20 7/16	29 1/8										23 7/8
1953 Stat. Wag. & Hard Top Coupe	48 3/4	53 13/16	53 13/16	53 13/16		51 1/8	48		31 3/4		5	5 3/4			47 3/4	68 1/16			20 7/16	29 3/16										24 1/4

Dimension Point

FRAMES 1946 thru 1953 DODGE

Convertible Bodies

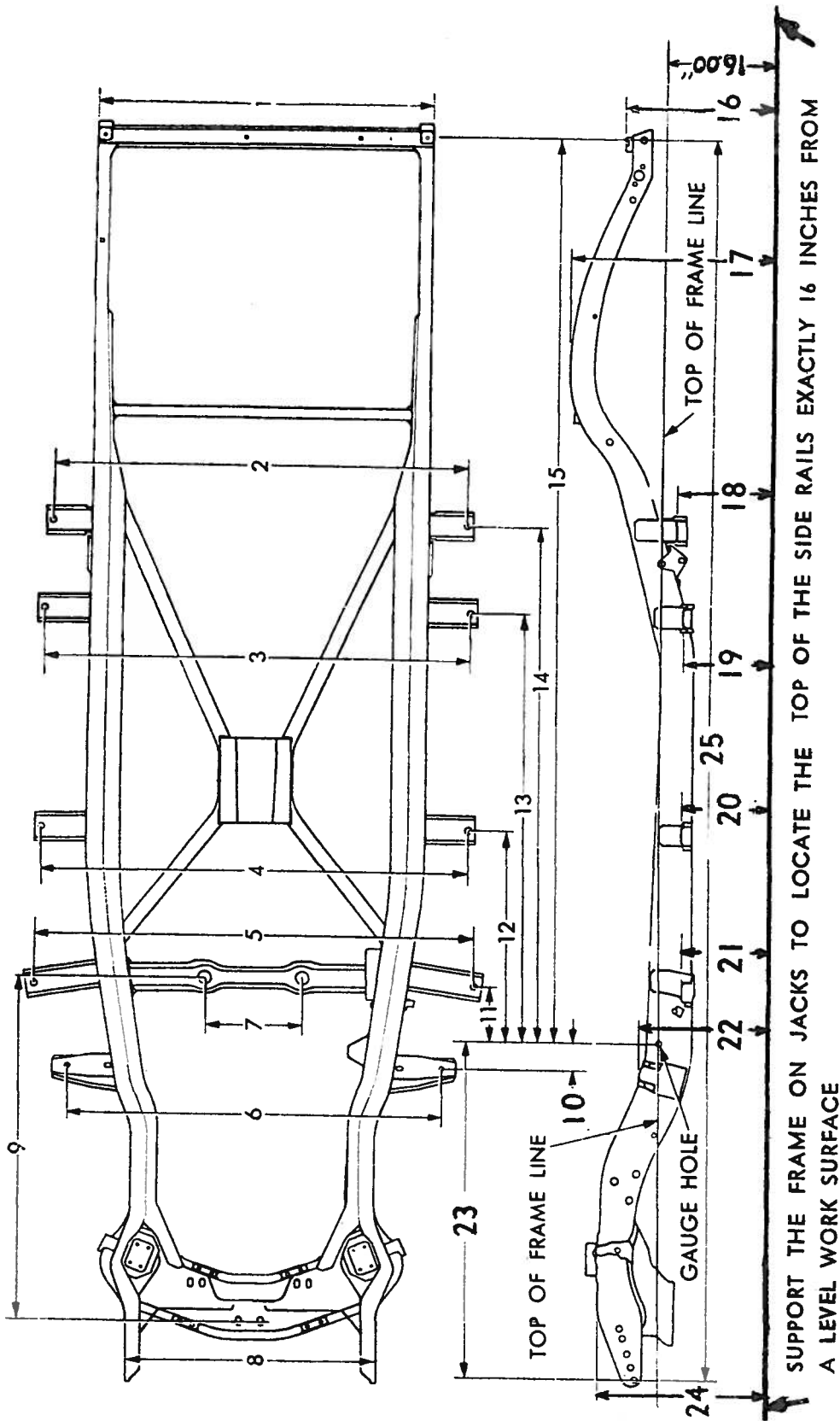

Model and Series	Dimension Point																								
	1	2	3	4	5	6	7	8	9	10	11	12	13	14	15	16	17	18	19	20	21	22	23	24	25
1948-1952 Convertible.....	43 1/2	53	54 7/16	54 7/16	56	50	12 3/8	31 3/4	45 35/64	4	7 1/16	28	57 1/8	77 1/4	129 1/8	21 13/32	28 3/32	141 3/16	137/32	137/32	133/16	182 3/64	45	23 7/8	174 1/8
1948-1952 Roadster	43 1/2	53	54 7/16	54 7/16	56	50	12 3/8	31 3/4	45 35/64	4	7 1/16	28	57 1/8	68 3/4	120 5/8	21 13/32	28 3/32	141 3/16	137/32	137/32	133/16	182 3/64	45	23 7/8	165 5/8
1953 Convertible...	46 13/16	53 7/8	53 7/8	53 7/8	51 3/16	48 1/8	...	31 13/16	...	5	5 3/4	31 7/8	47 3/4	68 1/16	...	20 7/16	28 3/16	24 1/4