

CHEVROLET 1949 thru 1953 BODY PARTS

ALL BODY STYLES

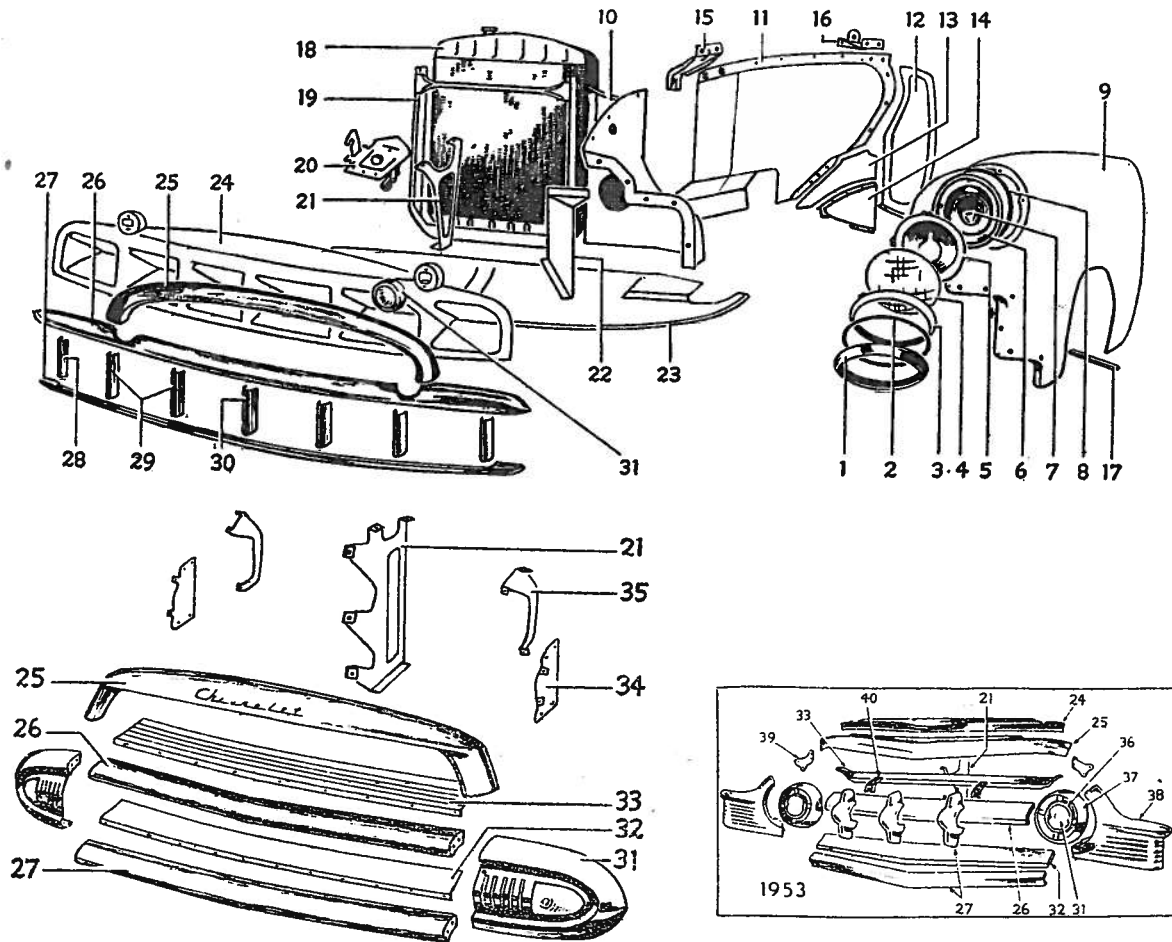

Fig. 1—Front Fender, Grilles, Lamps & Radiator; Typical of all 1949-53 models

Front of Car

See Fig. 1

HEADLAMP ASSEMBLY

926015—1949 to 52	11.15
926091—1953, all	12.30

1 HEADLAMP DOOR

5941285—1949 to 52	2.35
5943962—1953, all	2.65

2 LENS SEAL

5930594—1941 to 5335
--------------------------	-----

3 RETAINING RING

5940988—1941 to 53	1.50
--------------------------	------

4 SEALED BEAM UNIT

193195—1940 to 53	1.40
-------------------------	------

5 MOUNTING RING

924535—1940 to 53	1.20
-------------------------	------

6 SUB BODY

5936747—1949 to 52.....	3.35
5943963—1953	2.45

7 WIRING HARNESS

5938179—1949 to 52.....	1.60
5944090—1953	1.60

8 GASKET

3691000—1949 to 5318
--------------------------	-----

9 FRONT FENDER

3690631—1949 to 50 (left*)..	24.89
3694961—1951 to 52 (left*)..	24.37
3701581—1953 (left*)	24.37

10 FRONT SKIRT

3688519—1949 to 50 (left*)...	5.05
3694935—1951 to 52 (left*)..	4.94
3701905—1953 (left*)	5.05

11 REAR SKIRT

3700393—1949 to 51 (left) ...	6.26
3700394—1949 to 52 (right) ..	6.71
3701863—1953 (left*)	6.26

FRONT SKIRT SEAL

3688471—1949 to 50.....	.28
3694993—1951 to 52.....	.23
3701637—195323

REAR SKIRT SEAL

3688784—1949 to 52.....	.40
3701970—195317

12 FRONT FENDER BAFFLE

3688605—1949 to 52 (left*)..	2.05
3701983—1953 (left*)	2.05

13 FRONT FENDER LOWER BAFFLE

3690765—1949 to 52 (left*)...	1.0
-------------------------------	-----

14 EXTENSION BAFFLE

3690751—1949 to 52 (left*)..	1.0
3698023—1953 (left*)	1.0

REAR SKIRT TO FRAME SEAL

3688784—1949 to 534
--------------------------	----

REAR SKIRT TO DASH LEG SEAL

3690203—1949 to 531
--------------------------	----

15 FRONT FENDER SUPPORT BRACKET

3688707—1949 to 52 (left*)9
3701867—1953 (left*)9

16 FENDER TO DASH BRACE

3628665—1949 to 52 (left*)..	.7
3701615—1953 (left*)7

17 FENDER TO FRAME BRACE

3688603—1949 to 52.....	.3
3698051—19533

18 RADIATOR CORE

3121538—1949 to 52	60.8
3130944—1953	60.8

* Opposite side one part number higher

BODY PARTS 1949 thru 1953 CHEVROLET

ALL BODY STYLES

19 RADIATOR CORE SUPPORT	
3688458—1949 to 52.....	5.26
3702787—1953	5.26
20 HOOD LOWER CATCH PLATE	
3692800—1949 to 50.....	2.23
3695816—1951 to 52.....	1.86
3699310—1953	1.86
21 RADIATOR GRILLE CENTER SPACER	
3689254—1949 to 50.....	.85
3694929—1951 to 52.....	.71
3701635—195370
FRAME CROSS AND RADIATOR SUPPORT MEMBER	
3688035—1949 to 53, front ...	1.91
22 AIR FLOW DUCT BAFFLE	
3688935—1949 to 50 (left*)..	.88
3694945—1951 to 52 (left*)..	.75
3697855—1953 (left*)72
23 RADIATOR GRILLE FILLER PANEL	
3688439—1949 to 50.....	5.91
3694899—1951 to 52.....	5.91
3697958—1953	5.50
24 GRILLE REINFORCEMENT	
3688406—1949	6.91
3692600—1950	6.91
3694926—1951 to 52, header bar	.83
3701630—1953	1.23
25 RADIATOR GRILLE UPPER MOLDING	
3688269—1949 to 50.....	8.57
3699046—1951	8.97
3700078—1952	8.57
3701629—1953	6.90
26 GRILLE CENTER MOLDING	
3688271—1949 to 50.....	7.66
3699047—1951	6.88
3700074—1952	6.90
3697848—1953	6.90
27 GRILLE LOWER MOLDING	
3693966—1949 to 50.....	7.66
3699048—1951 to 52.....	6.88
3697849—1953	6.95
28 GRILLE OUTER VERTICAL MOLDING	
3688383—1949 to 50 (left*)..	.78
3700077—1952 (left*)	1.28
3698015—1953 (left*)	2.95
29 GRILLE INTERMED. MOLDING	
3688382—194978
3692803—1950 (left*) vertical	1.60
3700079—1952 (left*)	1.28
30 GRILLE CENTER VERTICAL MOLDING	
3688381—194978
1 PARKING LAMP	
928541—1949	4.20
928560—1950	4.50
928693—1951 (left*)	5.00
928763—1952	5.20
928476—1953	3.60

PARKING LAMP LENS	
5938155—194955
5939299—195055
5939934—195145
5943032—195282
5943220—195345
PARKING LAMP GASKET	
5938157—1949 to 50.....	.10
5939935—195115
5943033—195225
5943221—195320
PARKING LAMP WIRE HARNESS	
5943620—1949 to 5280
32 LOWER BAR AIR DEFLECTOR	
3694933—1951 to 52.....	1.28
3697860—1953	1.28
33 CENTER BAR AIR DEFLECTOR	
3694928—1951	1.49
3699636—1952	1.49
3697859—1953	1.28
34 OUTER BAR TIE PLATE (Left*)	
3699051—1951 to 5298
35 OUTER SPACER	
3694943—1951 to 52 (left*)..	.28
36 PARKING LAMP DOOR	
5943739—1951 (left*)	3.65
5942983—1952 (left*)	3.10
5943222—1953	1.40
37 PARKING LAMP HOUS.	
3701869—1953 (left*)	4.65
3698144—195312
38 GRILLE END MLDG.	
3701631—1953 (left*)	4.90
39 PARKING LAMP BRKT.	
3701633—1953 (left*)10
40 GRILLE VERT. BAR RET.	
3705080—195327

Hood Assembly

See Fig. 2

1 TOP PANEL	
3699625—1949 to 51 (left*) ...	14.88
3699625—1952 (left*)	14.88
3701597—1953 (left*)	14.88
2 EMBLEM	
3693312—1949-50	1.69
3699032—1951	1.82
3699646—1952	2.95
3702726—1953 (left*)	4.25
3 UPPER CATCH PLATE	
3688965—1949 to 52	1.54
3702012—1953	1.65
4 UPPER CATCH PLATE SPRING	
3690914—1940 to 5313
5 SPRING RETAINER	
3654458—1940 to 5308
6 BOLT	
2227394—1940 to 5332
7 HINGE	
3688409—1949 to 52 (left*)...	1.86
3697373—1953 (left*)	1.86
8 HINGE SPRING	
3689075—1949-5285
3700259—195395
9 FRONT HOOD MOLDING	
3688255—1949 to 5272
3701989—195338
10 TOP REAR MOLDING	
3701990—1949 to 5272
3701990—195372
11 HOOD TOP ORNAMENT	
3688253—1949-50	4.07
3699033—1951	5.00
3699491—1952	5.32
3701529—1953	4.25

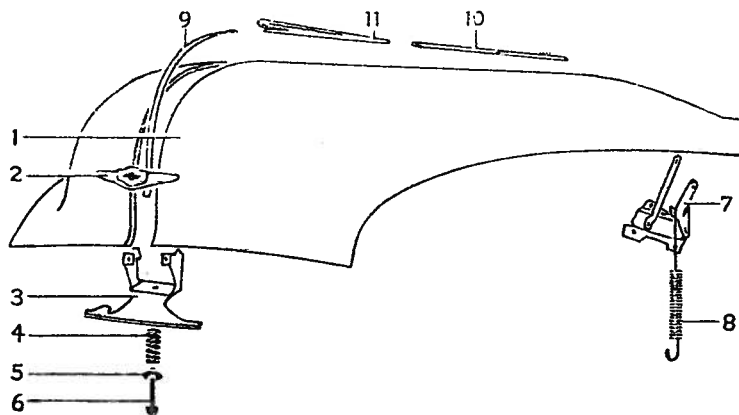

Fig. 2—Hood Assembly—Typical of all models—1949 to 1953

* Opposite side one part number higher

CHEVROLET 1949 thru 1953 BODY PARTS

ALL BODY STYLES

Front Bumper

See Fig. 3

1 CENTER FACE BAR	
3698604—1949-50	4.29
3698604—1951-52	4.29
3697345—1953	4.75
2 OUTER FACE BAR	
3698605—1949 to 52 (left*)	5.57
3697341—1953 (left*)	5.57
3 GUARD	
3698611—1949 (left*)	2.89
3692625—1950 (left*)	3.29
3698607—1951-52 (left*)	3.29
3697477—1953 (left*)	3.05

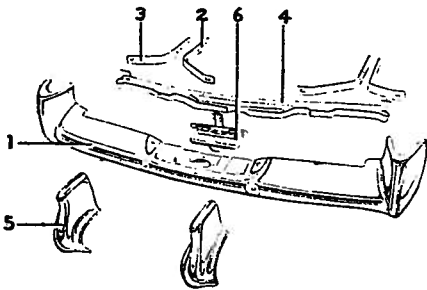

Fig. 3

4 FRONT LICENSE PLATE GUARD	
3690351—1949	5.52
3692622—1950	3.91
3698613—1951-52	3.91
5 INNER ATTACHING BAR	
3688285—1949 to 52 (left*)	1.52
3697693—1953 (left*)	1.52
6 OUTER ATTACHING BAR	
3692451—1949 to 52 (left*)	1.78
3697695—1953 (left*)	1.78

7 INTERMEDIATE ATTACHING BAR	
3689379—1949 to 52 (left*)	1.51
3697697—1953 (left*)	1.51

Body Sheet Metal and Fuel Tank

2-Door Sedans and Coupes

See Fig. 4

1 COWL ASSEMBLY, W/DASH	
4582467—1949-50, B.S. 1011-27-1211-27-27B-71	96.77
4582469—1949-50, B.S. 1007-1207	96.77
4613220—1951-52, B.S. 1011-27-1211-27-27B-71	96.77
4613222—1951-52, B.S. 1007-1207	96.77
4599698—1953	99.75

2 COWL SIDE PANEL	
4562034—1949 to 52 (right*)	5.98
4593547—1953 (right*)	5.98

COWL PANEL REINFORCEMENT (W/Anchor Plate)	
4566366—1950 to 52 (right*)	1.10
4619977—1953 (right*)	1.00

WINDSHIELD UPPER INNER FRAME	
4578125—1949 to 52	4.34
4602465—1953	4.60

3 COWL SIDE RAIL	
4579466—1949, B.S. 1007-1207 (right*)	10.86
4580969—1949-50, B.S. 1011-27-1211-27-27B-71 (right*)	11.94
4580971—1950-51, B.S. 1007-1207 (right*)	10.86

4587379—1951-52, B.S. 1011-27-1211-27-27B-71 (right*)	10.86
4591684—1951-52, B.S. 1011-27-1211-27-27B-71 (left)	10.86
4591678—1951-52, B.S. 1007-1207	10.86
4595028—1953 (right*)	4.11

DASH TO FRAME BRACE	
4560501—1949 to 52 (right*)	3.37
4596251—1953 (right*)	3.37

4 DOOR OUTER PANEL	
4562829—1949 to 52, B.S. 1011-1211 (right*)	16.86
4562835—1949 to 52, B.S. 1027-1227-27B (right*)	16.86
4562847—1949 to 52, B.S. 1007-1207 (right*)	16.86
4596743—1953 (right*)	17.21

5 DOOR INNER ROCKER PANEL	
4580153—1949 to 52 (right*)	3.26
4594484—1953 (right*)	3.26

6 DOOR OUTER ROCKER PANEL	
4169448—1949 to 52 (right*)	10.25
4191114—1953 (right*)	10.25

7 WHEEL HOUSE PANEL	
4559484—1949-50 (right*)	12.45
4614707—1951-52 (right*)	12.45
4598744—1953 (right*)	13.21

8 WHEEL HOUSE GRAVEL DEFLECTOR	
4562723—1949-50 (right*)92
4588247—1951-52 (right*)92

9 WHEEL HOUSE ACCESS HOLE COVER	
4571663—1949-50	1.90
4591011—1951-52 (right*)	1.90

GAS TANK FILLER NECK COMPARTMENT DOOR	
4583006—1949-50	1.90
4587976—1951-52	2.12
4597951—1953	2.12

DOOR SPRING	
4561926—194915
4583003—1950 to 5317

DOOR BUMPER	
4569867—191908
4581256—1950 to 5307

10 REAR QUARTER SIDE OUTER PANEL ASSEMBLY	
4581073—1949-50, B.S. 1007-1207 (right*)	54.14
4584723—1949-50, B.S. 1027-1227-27B (left)	54.14
4565074—1949-50, B.S. 1027-1227-27B (right)	54.14
4581017—1949-50, B.S. 1011-1211 (right*)	54.14
4611493—1951-52, B.S. 1007-1207 (right*)	61.78
4611930—1951-52, B.S. 1011-1211 (right*)	61.78
4611678—1951-52, B.S. 1027-1227-27B (right*)	56.78
4196466—1953 (right*)	58.75

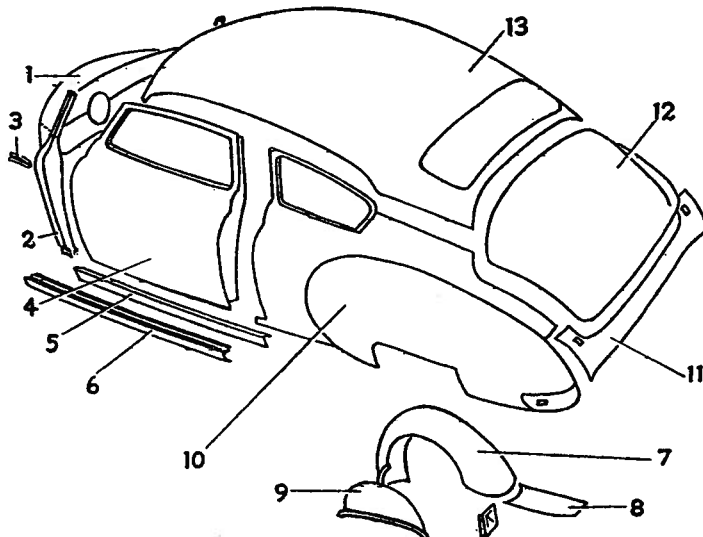

Fig. 4—Body sheet metal

* Opposite side one part number higher

BODY PARTS 1949 thru 1953 CHEVROLET

ALL BODY STYLES

REAR QUARTER SIDE OUTER PANEL (Outer Panel Only)

4585703—1949-50, B.S. 1007-1207 (right*)	38.00
4585715—1949-50, B.S. 1027-1227-27B (right*)	40.65
4585728—1949-50, B.S. 1011-1211 (right*)	38.00
4588102—1951-52, B.S. 1007-1207 (right*)	40.75
4588168—1951-52, B.S. 1011-1211 (right*)	40.75
4588081—1951-52, B.S. 1027-1227-27B (right*)	41.74
4196464—1953 (right*)	43.35

REAR QUARTER SIDE INNER PANEL

4562222—1949, B.S. 1027 (right*)	13.03
4562598—1949, B.S. 1011-1211 (right*)	15.20
4562603—1949, B.S. 1007-1207 (right*)	15.75
4585754—1949, B.S. 1227-27B (right*)	7.60
4593901—1950, B.S. 1011-1211 (right*)	15.20
4593901—1950-51, B.S. 1007-1207 (right)	15.20
4593902—1950, B.S. 1007-1207 (left)	15.20
4585752—1950-51, B.S. 1027 (right*)	13.58
4585754—1950-51, B.S. 1227-27B (right*)	7.60
4593902—1951-52, B.S. 1007-1207 (left*)	15.20
4593903—1951-52, B.S. 1011-1211 (right*)	15.20
4598528—1953	7.60

LOCK PILLAR UPPER SECTION

4173462—1949, B.S. 1011-1211 (right*)	4.89
4173460—1949, B.S. 1007-1207 (right*)	4.17
4585748—1950 to 52, B.S. 1007-1207 (right*)	1.78
4178250—1950 to 52, B.S. 1011-1211 (right*)	2.72

11 BODY BACK LOWER PANEL

4584482—1949-50, Fleet Line.	10.11
4584477—1949-50, B.S. 1011-1211	9.32
4588359—1951-52, Fleet Line.	6.78
4588360—1951-52, Style Line.	7.34
4596662—1953	5.90

12 REAR COMPARTMENT LID

4180870—1949 to 51, B.S. 1011-1211	38.80
4180876—1949 to 51, B.S. 1027-1227-27B	43.14
4180873—1949 to 52, B.S. 1007-1207	38.80
4591175—1953	40.50

13 TURRET TOP ROOF PANEL

3692556—1949 to 52, B.S. 1007-1207	53.49
4564767—1949 to 52, B.S. 1011-1211	54.29
4565080—1949 to 52, B.S. 1027-1227-27B	51.52
4598490—1953	51.52

REAR WHEEL COVER PANEL (Wheel Shield)

3693333—1949-50	7.32
3695982—1951-52	7.32
3705103—1953 (left*)	7.32

GASOLINE TANK

3694851—1949 to 52	18.18
3702862—1953	18.18

Body Moldings, Wheels and Glass

*2-door Sedans & Coupes
See Fig. 5*

1 HOOD TOP MOLDING

3688255—1949 to 52, top front.	.72
3701990—1949 to 52, top rear	.72
3701990—1953, top rear	.72
3701989—1953, top front	.38

2 HOOD ORNAMENT

3688253—1949 to 50	4.07
3699033—1951	5.00
3699491—1952	5.32
3701529—1953	4.25

3 WINDSHIELD GLASS

4561510—1949 to 52, B.S. 1011-27-1211-27-27B-71 (right*)	21.97
4561512—1949 to 52, B.S. 1007-1207 (right*)	21.25
4612502—1953	61.95

4 WINDSHIELD DIVISION OUTER MOLDING

4573832—1949 to 52	.95
--------------------	-----

5 WINDSHIELD REVEAL MOLDING

4560828—1949 to 52, B.S. 1011-27-1271 (right upper*)	3.02
4560915—1949 to 52, B.S. 1007 (right upper*)	2.73
4560942—1949 to 52, Ser. 1000 (right lower corner*)	.98
4562378—1949 to 52, all (right lower*)	2.13
4605763—1953 (right up*)	2.52
4605765—1953 (right low*)	.98

continued

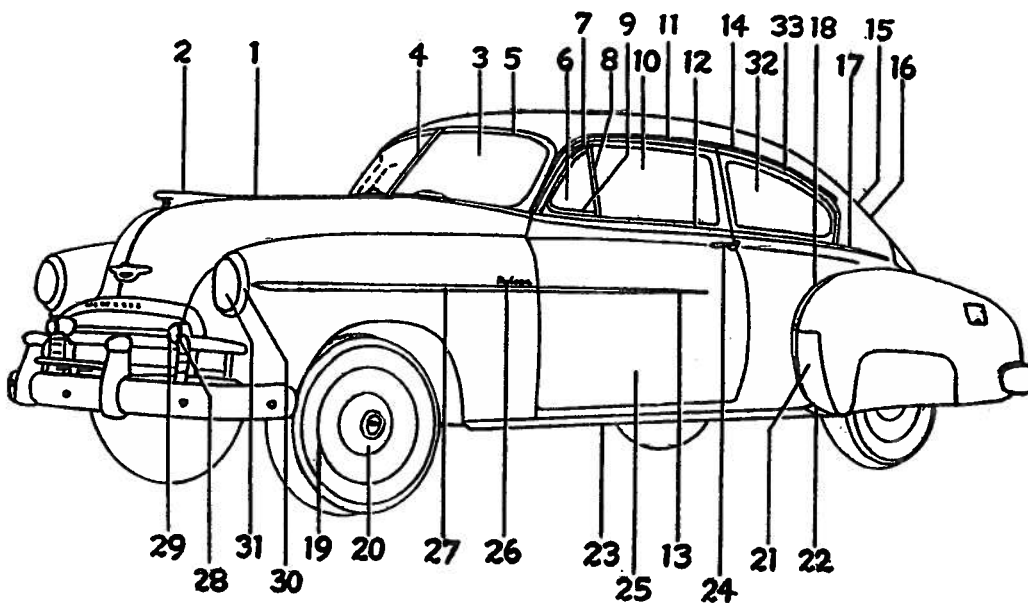

Fig. 5—Body Moldings, Wheels and Glass—2-Door Sedans and Coupes

* Opposite side one part number higher

CHEVROLET 1949 thru 1953 BODY PARTS

ALL BODY STYLES

Body Moldings, Wheels and Glass—continued

6 DOOR VENTILATOR GLASS					
4560574—1949 to 52, Fleetline.	3.92				
4561275—1949 to 52, Styleline.	4.20				
4599944—1953	4.05				
7 DOOR RAIN DEFLECTOR					
4583977—1949 to 52, Fleetline (right*)	.70				
4583986—1949 to 52, Styleline (right*)	.70				
4597442—(right*)	.70				
8 DOOR GLASS DIVISION CHANNEL					
4574332—1949, B.S. 1211-27-27B-69-71 (right*)	3.55				
4593126—1949, B.S. 1007, 1st type (right*)	3.55				
4574338—1949, B.S. 1011-27, 1st type (right*)	3.55				
4574327—1949, B.S. 1207, 1st type (right)	3.55				
4593126—1949, B.S. 1007, 2nd type (right*)	3.55				
4574327—1949, B.S. 1207, 2nd type (right*)	3.55				
4574338—1949, B.S. 1011-27, 2nd type (right*)	3.55				
4582182—1950, B.S. 1011-27-1211-27-27B (right*)	3.55				
4582184—1950, Fleetline (right*)	3.55				
4151738—1951-52, B.S. 1011-27-1211-27-27B (right*)	4.07				
4593126—1951-52, Fleetline (right*)	3.55				
4151974—1953 (right*)	4.07				
9 DOOR VENTILATOR GLASS CHANNEL					
4167995—1949 to 52, Fleetline (right*)	5.38				
4167984—1949 to 52, Styleline (right*)	5.27				
4191722—1953 (right*)	5.27				
0 DOOR GLASS					
4559940—1949 to 52, B.S. 1011-1211	13.68				
4561192—1949 to 52, B.S. 1007-1207	12.60				
4559951—1949 to 52, B.S. 1027-1227-1227B	13.37				
4595550—1953	13.40				
1 WINDOW REVEAL MOLDING					
4560568—1949 to 52, B.S. 1011 (right*)	2.30				
4560570—1949 to 52, B.S. 1027 (right*)	2.30				
4560781—1949 to 52, B.S. 1007 (right*)	2.30				
4607637—1953 (right*)	2.95				
2 DOOR, UPPER BELT MOLDING					
4561291—1949 to 52, B.S. 1007-11-27-1207-11-27-27B (right*)	2.18				
4596622—1953 (right*)	2.22				
13 DOOR, LOWER BELT MOLDING					
4560098—1949-50, Ser. 100	2.10				
4587007—1951-52, B.S. 1007-11-27	2.90				
4613752—1953 (right*)	2.40				
14 ROOF DRIP MOLDING					
4560006—1949 to 52, B.S. 1007-1207 (right front*)	.65				
4559994—1949 to 52, B.S. 1011-27-1211-27-27B-71 (right front*)	.65				
4561189—1949 to 52, B.S. 1007-1207 (right side*)	1.90				
4559998—1949 to 52, B.S. 1027-1227-27B (right rear*)	.65				
4559996—1949 to 52, B.S. 1011-1211 (right rear*)	.82				
45964445—1953 (right*)	.65				
15 BACK WINDOW GLASS					
4559990—1949 to 52, B.S. 1007-1207	16.98				
4561843—1949 to 52, B.S. 1027-1227-27B	15.06				
4559993—1949 to 52, B.S. 1011-1211	16.98				
4596047—1953	22.25				
15 BACK WINDOW GLASS CHANNEL (Rubber)					
4564356—1949 to 52, B.S. 1211	4.25				
4564357—1949 to 52, B.S. 1011	4.25				
4564358—1949 to 52, B.S. 1007	3.97				
4564359—1949 to 52, B.S. 1227-27B	3.97				
4564360—1949 to 52, B.S. 1027	3.97				
4570888—1949 to 52, B.S. 1207	3.97				
4625735—1953	4.35				
16 BACK WINDOW GLASS REVEAL MOLDING					
4561487—1949 to 52, B.S. 1011 (right upper*)	2.73				
4561466—1949 to 52, B.S. 1027 (right upper*)	2.73				
4561502—1949 to 52, B.S. 1011 (lower)	2.13				
4561494—1949 to 52, B.S. 1027 (lower)	2.13				
4561617—1949 to 52, B.S. 1027 (right lower corner*)	1.10				
4561721—1949 to 52, B.S. 1011 (right lower corner*)	1.10				
4562137—1949 to 52, B.S. 1007 (right*)	3.55				
4595318—1953, 1027 (right*) up.	3.20				
4595093—1953, 1027 low	2.50				
17 REAR QUARTER BELT MOLDING					
4561955—1949 to 52, coupes (right*)	3.55				
4562043—1949 to 52, B.S. 1011-1211 (right*)	3.83				
4563260—1949 to 52, B.S. 1007-1207 (right*)	2.73				
4596789—1953, 1027 (right*)	3.67				
18 REAR FENDER CROWN MOLDING					
4561543—1949-50 (left rear*)	3.45				
4568119—1949-50 (right front*)	1.27				
3695257—1951, Ser. 1000	2.57				
986702—1952	8.05				
19 FRONT AND REAR WHEEL					
3687980—1949 to 53	10.78				
20 WHEEL HUB CAP					
3694318—1949-50	2.68				
3698555—1951-53	2.84				
21 REAR FENDER SHIELD					
4561729—1949-50, B.S. 1007-11-27 (right metal*)	6.87				
4561819—1949-50, B.S. 1207-11-27-27B (right rubber*)	3.12				
4589001—1951, B.S. 1007-11-27 (right metal*)	7.93				
4589005—1951, B.S. 1207-11-27-27B (right rubber*)	3.97				
4610633—1952, B.S. 1007-11-27 (right upper*)	2.93				
4603388—1953, 1000 (right*)	8.17				
4605178—1953, 1200 (right*)	4.07				
22 FENDER SHIELD EXTENSION ON ROCKER					
4566886—1949-50, B.S. 1207-11-27-27B (right*)	1.07				
4567431—1949-50, B.S. 1007-11-27 (right*)	2.63				
23 BODY SILL MOLDING					
3688947—1949 to 52 (left*)	4.02				
3698437—1953 (left*)	2.89				
24 DOOR HANDLE					
4168322—1949 to 52 (right*)	2.68				
4150568—1953, 1037 (right*)	2.77				
4150572—1953, 1037, 1027 (right*)	2.77				
25 DOOR, OUTER PANEL					
4562847—1949 to 52, B.S. 1007-1207 (right*)	16.88				
4562829—1949 to 52, B.S. 1011-1211 (right*)	16.88				
4562835—1949 to 52, B.S. 1027-1227-27B (right*)	16.88				
4191744—1953, 1011, 1211 (right*)	52.80				
4191122—1953, 1027, 37 (right*)	51.25				
26 FRONT FENDER NAME PLATE					
3692093—1949-50 (deluxe)	.63				
27 FRONT FENDER MOLDING					
3693873—1949-50, GK, HK	1.93				
3695287—1951, JK, Ser. 2100 (left*)	3.47				
3700036—1952, KK, Ser. 2100	1.84				
3698359—1953 (left*)	1.58				
28 PARKING LAMP ASSY.					
928541—1949	4.20				
928560—1950	4.50				
928693—1951 (left*)	5.00				
928763—1952 (left*)	5.20				
928476—1953	3.60				

* Opposite side one part number higher

BODY PARTS 1949 thru 1953 CHEVROLET

ALL BODY STYLES

3) PARKING LAMP LENS	
5938155—194955
5939299—195055
5939934—195145
5943032—195282
5943220—195345
4) HEADLAMP DOOR	
5941285—1949 to 52	2.35
5943962—1953	2.65
1) SEALED BEAM UNIT	
193195—1940 to 53	1.40
2) QUARTER WINDOW GLASS	
4561036—1949 to 52, B.S. 1011-1211	12.62
4561939—1949 to 52, B.S. 1027	8.48
4562015—1949 to 52, B.S. 1227-27B	7.06
4562221—1949 to 52, B.S. 1007-1207	12.62
4599419—1953, 1011, 1211	12.25
4601263—1953, 1027	8.83
4601264—1953, 1227	7.06
4599953—1953, CBL	8.12
4600839—1953, 1037	8.43
QUARTER WINDOW GLASS RUBBER CHANNEL (Right and left)	
4567736—1949 to 52, B.S. 1227-27B	1.87
4597180—1953, 1227	2.09
QUARTER WINDOW GLASS WEATHERSTRIP	
4562384—1949 to 52, B.S. 1027 (right rear*)23
4562297—1949 to 52, B.S. 1027 (right outer*)	1.53
4596466—1953, 1027 (right outer*)	1.57
QUARTER WINDOW GLASS RUN CHANNEL	
4091373—1949 to 52, B.S. 102718
4075477—1940 to 50, B.S. 1007-11-1207-11, upper	2.20
4597185—1953, 102717
4601620—1953, 1037 (right*)	8.60
QUARTER WINDOW GLASS CHANNEL RETAINER	
4586340—1949, B.S. 1007-11-1207-11 (right front and left rear*)40
4586339—1950 to 52, B.S. 1007-11-1207-11 (right front and left rear*)40
4597940—1953, 1011, 1211 (right*)40
QUARTER WINDOW LOWER S A S H C H A N N E L WEATHERSTRIP	
4099014—1942 to 52, B.S. 1007-11-1207-11	1.27
4099014—1953, 1007, 11-1207, 11	1.27

33) QUARTER WINDOW REVEAL MOLDING	
4561151—1949 to 52, B.S. 1011 (right*)	1.92
4561731—1949 to 52, B.S. 1027 (right*)	1.70
4561910—1949 to 52, B.S. 1007 (right*)	1.92
4617002—1953, 1011WD (right*) up	3.15
4617070—1953, 1011WD (right*) low	3.75
4617088—1953, 1011WD (right*) rear	3.75
4616705—1953, 1011WD (right*) front	1.55
4596120—1953, 1027 (right*) front	1.45
4596463—1953, 1027 (right*) rear	2.25
33) QUARTER WINDOW REGULATORY	
4561573—1949 to 52, B.S. 1007-11-1207-11 (right*)	4.40
4598503—1953, 1027, 37 (right*)	4.40
33) QUARTER WINDOW REGULATORY HANDLE	
4564255—1949, B.S. 1007-11	1.62
4564255—1949, B.S. 1207-11	1.62
4582151—1950, B.S. 1207-11	1.50
4582152—1950, B.S. 1007-11	1.62
4601168—1951-52, B.S. 1007-11	1.62
4594189—1951-52, B.S. 1207-11	1.50
4619387—1953, 1011, 27, 37	1.50
4619388—1953, 1211	1.50
33) QUARTER WINDOW REGULATORY CAM	
4099974—1941 to 53, B.S. 1007-1011-1207-1140
Body Sheet Metal and Fuel Tank	
<i>4-Door Sedan and Station Wagon</i>	
<i>See Fig. 6</i>	
1) COWL ASSEMBLY, W/DASH	
4582467—1949-50, B.S. 1069-1269	96.77
4582469—1949-50 B.S. 1008-1208	96.77
4582471—1950, sta. wag.	96.77
4613220—1951-52, B.S. 1008-1208-1069-1269	96.77
4613224—1951-52, sta. wag.	96.77
4599698—1953, 1069, 1269	99.75
4599705—1953, sta. wag.	101.40
2) COWL SIDE PANEL	
4562034—1949 to 52 (right*)	5.98
4593547—1953, 1069 (right low*)	5.98

3) COWL SIDE RAIL	
4587379—1949-50, B.S. 1069-1269 (right*)	10.86
4579466—1949, B.S. 1008-1208 (right*)	10.86
4580971—1950-51, B.S. 1008-1208 (right*)	10.86
4587379—1951-52, B.S. 1069-1269 (right)	10.86
4591684—1951-52, B.S. 1069-1269 (left)	10.86
4591678—1951-52, B.S. 1008-1208 (left)	10.86
4595028—1953, 1069, 1269 (right*)	4.15
4600149—1953, sta. wag. (right*)	4.35
4) FRONT DOOR OUTER PANEL	
4562781—1949 to 52, B.S. 1069-1269 (right*)	15.20
4562869—1949 to 52, B.S. 1008-1208 (right*)	15.20
4581242—1949 to 52, B.S. 1062 (right*)	15.20
4571052—1949, B.S. 1061 (right lower*)	20.09
4596749—1953, 1069, 1269 (right*)	15.69
4601514—1953, sta. wag. (right*)	15.34
5) CENTER BODY PILLAR	
4578489—1949 to 52, B.S. 1008-1208 (right*)	21.17
4578497—1949 to 52, B.S. 1069-1269 (right*)	21.17
4578491—1949 to 52, B.S. 1062 (right*)	21.17
4566036—1949, B.S. 1061 (right*)	30.94
4598363—1953, 1069, 1269 (right*)	21.50
4601552—1953, sta. wag. (right*)	21.50
6) REAR DOOR OUTER PANEL	
4175383—1949 to 52, B.S. 1062 (right*)	15.20
4174402—1949 to 52, B.S. 1008-1208 (right*)	15.20
4174219—1949 to 52, B.S. 1069-1269 (right*)	15.20
4571056—1949, B.S. 1061 (right lower*)	21.17
4191752—1953, 1069, 1269 (right*)	15.55
4191756—1953, sta. wag. (right*)	14.60
7) DOOR INNER ROCKER PANEL	
4580153—1949 to 52 (right*)	3.26
4594484—1953 (right*)	3.26
8) DOOR OUTER ROCKER PANEL	
4169448—1949 to 52 (right*)	10.29
4191114—1953 (right*)	10.29
9) WHEEL HOUSE PANEL	
4559482—1949-50, B.S. 1008-69-1208-69 (right*)	12.49

* Opposite side one part number higher

continued

CHEVROLET 1949 thru 1953 BODY PARTS

ALL BODY STYLES

Body Sheet Metal and Fuel Tank—continued

See Fig. 6

4614715—1949 to 52, B.S. 1061-1062 (right*)	12.49
4614711—1951-52, B.S. 1008-69-1208-69 (right*)	12.49
4608566—1953, 1069, 1269 (right*)	15.15
4600186—1953, sta. wag. (right*)	13.85
10 GRAVEL DEFLECTOR	
4562723—1949-50 (right*)92
4588247—1951-52 (right*)92
11 WHEEL HOUSE ACCESS HOLE COVER	
4571663—1949-50, exc. 1061... ..	1.90
4591011—1951-52, closed exc. SDL (right*)	1.90
4571663—1951-52, sta. wag. and SDL	1.90
4568536—1949 to 51, B.S. 1062 (right*)	2.98
4605850—1953, sta. wag. (right*)	1.42
12 GAS TANK FILLER NECK COMPARTMENT DOOR	
4583006—1949-50	1.90
4587976—1951-52, closed exc. SDL	2.12
4597951—1953, pass.	2.12
DOOR SPRING	
4561926—194915
4583003—1950 to 5317
DOOR BUMPER	
4569867—194908
4581256—1950 to 5307
13 REAR QUARTER SIDE OUTER PANEL ASSEMBLY	
4581033—1949-50, B.S. 1008-1208 (right)	41.02
4581034—1949, B.S. 1008-1208 (left)	41.02
4581053—1949-50, B.S. 1069-1269 (right*)	41.02
4565111—1949 to 51, B.S. 1062 (right*)	54.14
4570751—1949, B.S. 1061 (right frame assy.*)	180.42
4581034—1950, B.S. 1008-1208 (left)	41.02
4588138—1951-52, B.S. 1008-1208 (right*)	47.29
4611922—1951-52, B.S. 1069-1269 (right*)	47.29

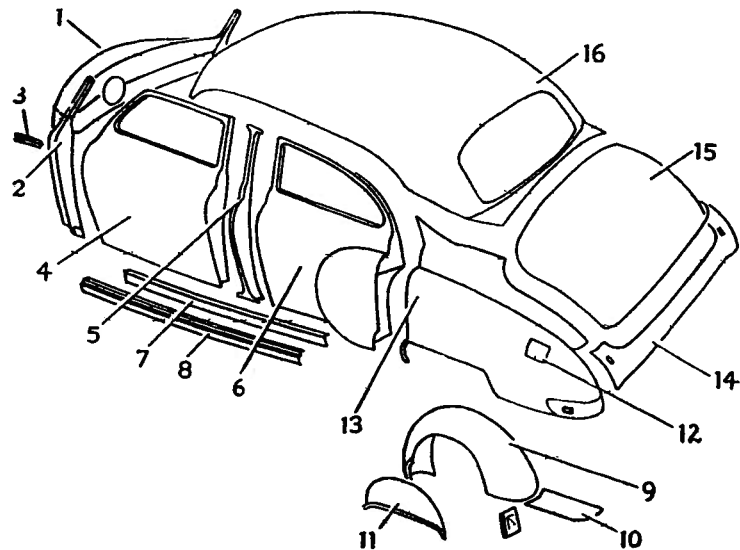

Fig. 6—Body Sheet Metal and Fuel Tank

4191863—1953, 1069, 1269 (right*)	49.00	4584482—1949-50, B.S. 1008-1208	10.1
4599440—1953, sta. wag. (right*)	55.75	4584486—1949 to 51, B.S. 1062	7.0
13 REAR QUARTER SIDE OUTER PANEL (Outer Panel Only)		4588359—1951-52, B.S. 1008-1208	6.7
4560534—1949 to 52, B.S. 1062 (right lower*)	13.68	4588360—1951-52, B.S. 1069-1269	7.3
4567126—1949, B.S. 1061 (right lower*)	13.68	4596662—1953, 1069, 1269	5.8
4571218—1949-50, B.S. 1069-1269 (right*)	19.14	4602363—1953, sta. wag.	6.5
4571717—1949-50, B.S. 1008-1208 (right*)	19.14	15 REAR COMPARTMENT LID	
4585441—1951, B.S. 1008-1208 (right*)	21.05	4180870—1949 to 51, B.S. 1069-1269	38.8
4586788—1951-52, B.S. 1069-1269 (right*)	21.05	4180873—1949-50, B.S. 1008-1208	38.8
4191861—1953, 1069, 1269 (right*)	21.80	4180873—1951-52, B.S. 1008-1208	38.8
4612847—1953, sta. wag. (right low.*)	13.95	4591175—1953, 1069, 1269	40.1
13 REAR QUARTER SIDE INNER PANEL		16 TURRET TOP ROOF PANEL	
4559599—1949, B.S. 1069-1269 (right*)	1.78	3692556—1949 to 52, B.S. 1008-1208	53.4
4561425—1949, B.S. 1008-1208 (right*)	1.35	3692557—1949 to 52, B.S. 1069-1269	53.4
4585831—1950-51 B.S. 1008-1208 (right*)	1.63	4565113—1949 to 52, B.S. 1062	74.8
4580901—1950 to 52, B.S. 1069-1269 (right*)	1.48	4571092—1949—B.S. 1061	74.8
4605847—1953, 1069, 1269 (right*)	3.65	4598629—1953, 1069	49.1
14 BODY BACK LOWER PANEL.		4598567—1953, 1269	50.1
4584477—1949-50, B.S. 1069-1269	9.32	GASOLINE TANK	
		3694851—1949 to 52, exc. SDL and sta. wag.	18.1
		3688100—1949 to 52, SDL, sta. wag.	19.0
		3702862—1953, sedan	18.1
		3688100—1953, sta. wag.	19.1

* Opposite side one part number higher

BODY PARTS 1949 thru 1953 CHEVROLET

ALL BODY STYLES

Body Moldings, Wheels and Glass

4-Door Sedans and Station Wagons

See Fig. 7

1953 Bel Air Models See Page 189

HOOD FRONT MOLDING	
3688255—1949 to 5272
3697373—1953, pass. (left*) ..	1.86

HOOD TOP REAR MOLDING	
3701990—1949 to 5272
3701989—1953, pass. front38
3701990—1953, pass. rear72

HOOD ORNAMENT	
3688253—1949-50	4.07
3699033—1951	5.00
3699491—1952-53	5.32

WINDSHIELD GLASS	
4561510—1949 to 52, B.S. 1069-1269 (right*)	21.97
4561512—1949 to 52, B.S. 1008-1208 (right*)	21.25
4564409—1949 to 52, B.S. 1061-1062 (right*)	24.72
4612502—1953, 1069, 1269	61.95
4615797—1953, sta. wag.	67.55

WINDSHIELD DIVISION OUTER MOLDING	
4573832—1949 to 52, exc. Fleetline95
4573833—1949 to 52, Fleetline ..	.97
4573834—1949 to 52, sta. wag..	.95

WINDSHIELD REVEAL MOLDING	
4560828—1949 to 52, B.S. 1069 (right upper*)	3.02

4560915—1949 to 52, B.S. 1008 (right upper*)	2.73
4563588—1949 to 52, B.S. 1061-1062 (right upper*)	3.55
4560942—1949 to 52, Ser. 1000 and SDL (right lower corner*)93
4562378—1949 to 52, pass. (right lower corner*)	2.13
4600835—1953, 1062, 62F up. (right*)	2.73
4605763—1953, 1069 up. (right*)	2.52
4605765—1953, 1069 low. (right*)90
4600837—1953, 1062, 62F low. (right*)98

WINDSHIELD GLASS RUBBER CHANNEL	
4587341—1949, B.S. 1269, early ..	7.07
4587340—1949-50, B.S. 1069 ..	7.07
4587341—1949-50, B.S. 1269 ..	7.07
4573858—1949 to 51, B.S. 1061-1062	7.07
4585280—1949 to 52, B.S. 1008. (right*)	7.07
4585281—1949 to 51, B.S. 1208. (right*)	7.07
4587340—1952-53, B.S. 1069 ..	7.07
4587341—1952, B.S. 1269	7.07
4615798—1953, 1062, 62F	5.75
4616476—1953, 1262F	5.75

7 FRONT DOOR VENTILATOR GLASS	
4560574—1949 to 52, Fleetline ..	3.92
4561275—1949 to 52, Styleline ..	4.20
4599944—1953	4.05

DOOR RAIN DEFLECTOR	
4583977—1949 to 52, Fleetline (right*)70
4583986—1949 to 52, Styleline (right*)70

4597442—1953, 1069, 1269 (right*)70
4600722—1953, sta. wag. (right*)70

8 FRONT DOOR GLASS DIVISION CHANNEL	
4574332—1949, B.S. 1269 (right*)	3.55
4604076—1949, sta. wag. (right*)	4.33
4593126—1949, B.S. 1008 (right*)	3.55
4574338—1949, B.S. 1069 (right*)	3.55
4574327—1949, B.S. 1208 (right)	3.55
4593126—1949, B.S. 1008 (right*)	3.55
4574327—1949, B.S. 1208 (right*)	3.55
4604076—1949 to 51, sta. wag. (right*)	4.33
4574338—1949, B.S. 1069 (right*)	3.55
4582182—1950, B.S. 1069-1269 (right*)	3.55
4582184—1950, Fleetline (right*)	3.55
4151738—1951, B.S. 1069-1269 (right*)	4.07
4593126—1951, Fleetline (right*)	3.55
4151738—1952, B.S. 1069 (right*)	4.07
4151738—1952, Ser. 1200 (right*)	4.07
4151738—1952, exc. Fleetline (right*)	4.07
4151736—1952, Fleetline (right*)	4.07
4151974—1953 (right*)	4.07

continued

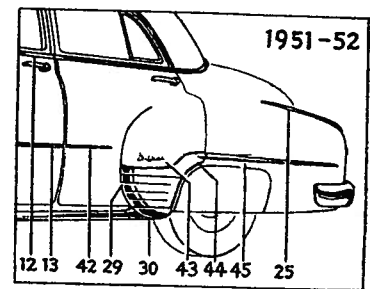
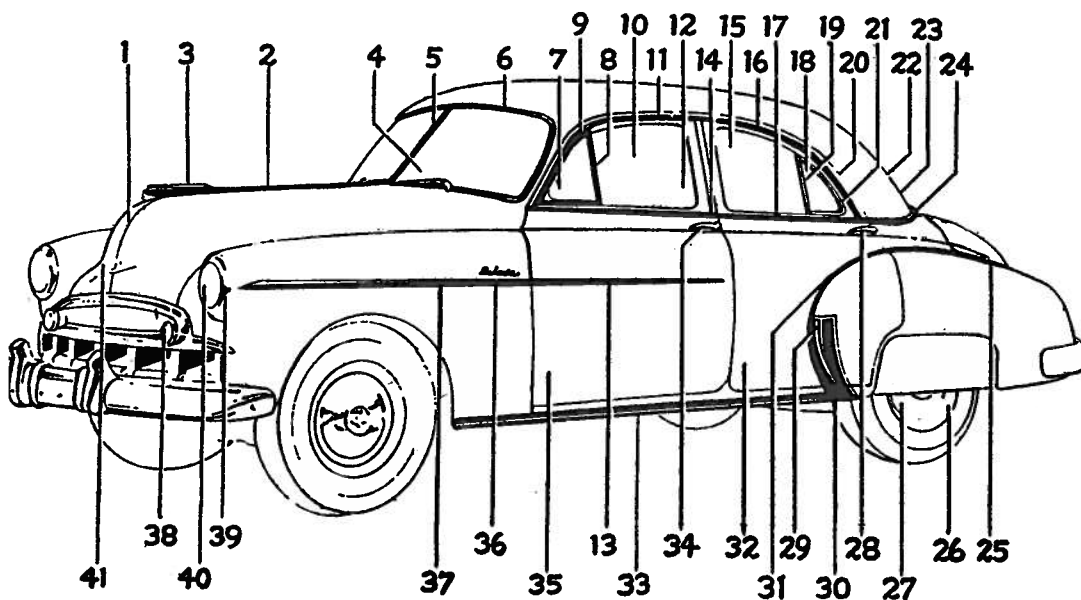

Fig. 7—Moldings, Wheels and Glass

** Opposite side one part number higher*

CHEVROLET 1949 thru 1953 BODY PARTS

ALL BODY STYLES

Moldings, Wheels and Glass —continued

9 FRONT DOOR VENTILATOR GLASS CHANNEL		4603760—1953, 1069WD, header (right*)	2.13	4577610—1949, B.S. 1269, 1st type, stationary glass (right*)	2.
4167984—1949 to 52, Styleline (right*)	5.27	4628184—1953, 1069WD, up.. (right*)	2.95	4577611—1949 to 52, B.S. 1269, stationary glass (left*)	2.
4167995—1949 to 52, Fleetline (right*)	5.38	4628186—1953, 1069WD, low. (right*)	3.35	22 BACK WINDOW GLASS	
4191722—1953 (right*)	5.27	17 REAR DOOR UPPER BELT MOLDING		4559990—1949 to 52, B.S. 1008-1208	16.1
10 FRONT DOOR GLASS		4561339—1949 to 52, B.S. 1069-1269 (right*)	1.92	4559993—1949 to 52, B.S. 1069-1269	16.1
4559295—1949 to 52, B.S. 1069-1269-71	10.65	4561337—1949 to 51, B.S. 1008-1208 (right*)	1.92	4616101—1953, 1069	36.1
4560558—1949 to 51, B.S. 1008-1208	9.72	4597183—1953, 1069W, 1269 (right*)	1.92	4612527—1953, 1269	27.
4566722—1949, B.S. 1061	9.48	4628188—1953, 1069WD (right*)	2.50	23 BACK WINDOW GLASS REVEAL MOLDING	
4566721—1949 to 52, B.S. 1062	9.69	4599650—1953, sta. wag. (right*)	1.95	4561487—1949 to 52, B.S. 1069 (right upper*)	2.1
4599950—1953, 1069, 1269	10.25	18 REAR DOOR VENTILATOR GLASS		4561502—1949 to 52, B.S. 1069 (lower)	2.1
4603203—1953, 1062, 62F	9.85	4559589—1949 to 52, B.S. 1069.	3.83	4561721—1949 to 52, B.S. 1069 (right lower corner*)	1.1
4603297—1953, 1262F	8.08	4560940—1949 to 51, B.S. 1008.	2.97	4562197—1949 to 52, B.S. 1008 (right*)	3.1
11 FRONT DOOR WINDOW REVEAL MOLDING		4560086—1949 to 52, B.S. 1269, stationary section	3.80	4595992—1953, 1069 up.	3.1
4560584—1949 to 52, B.S. 1069 (right*)	2.13	4570656—1949 to 51, B.S. 1208, stationary section	2.86	4595992—1953, 1069W, low. (right*)	2.1
4560783—1949 to 51, B.S. 1008 (right*)	2.13	19 REAR DOOR GLASS DIVISION CHANNEL		BACK WINDOW GLASS CHANNEL (Rubber)	
4603631—1953, 1069WD up. (right*)	2.80	4568934—1949, B.S. 1269, 1st type (right*)	3.55	4564356—1949 to 52, B.S. 1269	4.1
4603793—1953, 1069WD low. (right*)	3.50	4151740—1949 to 52, B.S. 1069 (right*)	3.87	4564357—1949 to 52, B.S. 1069	4.1
12 FRONT DOOR UPPER BELT MOLDING		4604078—1949 to 51, B.S. 1008 (right*)	3.55	4564358—1949 to 52, B.S. 1008	3.1
4561289—1949 to 51, B.S. 1008-69-1208-69 (right*)	2.02	4577624—1949, B.S. 1208, 1st type (right*)	2.98	4570888—1949 to 51, B.S. 1208	3.1
4564416—1949 to 51, B.S. 1062 (right*)	2.57	4577620—1949, B.S. 1269, 2nd type (right*)	3.55	4625735—1953, 1269	4.1
4596624—1953, 1069W, 1269 (right*)	2.02	4577624—1949, B.S. 1208, 2nd type (right*)	2.98	4616107—1953, 1069	5.1
4599093—1953, sta. wag. (right*)	2.13	4580637—1950, B.S. 1208 (right*)	2.98	24 REAR QUARTER BELT MOLDING	
13 DOOR LOWER OUTER PANEL BELT MOLDING		4580639—1950, B.S. 1269 (right*)	3.55	4561872—1949 to 52, B.S. 1069-1269 (right*)	2.1
4560098—1949-50, Ser. 1000...	2.10	4608487—1951, B.S. 1269 (right*)	3.55	4562911—1949 to 51, B.S. 1008-1208 (right*)	2.0
4587005—1952, B.S. 1008-62-69	2.57	4608488—1952, B.S. 1269 (right*)	3.55	4597201—1953, 1069, 1269 (right*)	2.1
4587007—1951-52, B.S. 1007-11	2.90	20 ROOF DRIP MOLDING		4600536—1953, sta. wag. (right*)	2.1
4603085—1953, 1062, 62F, 69 ..	2.30	4561189—1949 to 52, B.S. 1008-1208 (right*)	1.90	25 FENDER CROWN MOLDING	
14 CENTER PILLAR UPPER BELT MOLDING		4561161—1949 to 52, B.S. 1069-1269 (right*)	1.03	4561544—1949-50 (right*)	2.1
4564586—1949 to 53, B.S. 1008-69	.33	4564950—1949 to 52, sta. wag. (right rear*)	.65	4561544—1951, sta. wag. (right*)	2.1
15 REAR DOOR GLASS		4564116—1949 to 52, sta. wag. (rear end)	1.35	986702—1952	8.0
4559296—1949 to 52, B.S. 1069-1269	10.75	4596445—1953, 4 dr. (right*)	.65	26 FRONT AND REAR WHEEL	
4560991—1949 to 51, B.S. 1008-1208	11.72	4599542—1953, sta. wag. (right*)	1.03	3687980—1949 to 53	10.1
4566723—1949 to 52, B.S. 1062.	16.26	21 REAR DOOR VENTILATOR GLASS CHANNEL		27 WHEEL HUB CAP	
4566724—1949, B.S. 1061	15.72	4167997—1949 to 51, B.S. 1008 (right*)	4.92	3694318—1949-50	2.1
4600533—1953, 1069 1269	12.95	4167999—1949 to 52, B.S. 1069 (right*)	4.92	3698555—1951 to 53	2.1
4603271—1953, 1062, 62F	15.58	29 FENDER SHIELD		4561470—1949-50, B.S. 1008-69, metal (right*)	5.1
4603539—1953 1262F	13.06				

* Opposite side one part number higher

BODY PARTS 1949 thru 1953 CHEVROLET ALL BODY STYLES

4561470—1949 to 51, B.S. 1061-1062, metal (right*)	5.32
4561762—1949-50, B.S. 1208-69, rubber (right*)	2.78
4587725—1951-52, B.S. 1008-69, metal (right*)	5.25
4587729—1951-52, B.S. 1208-69, rubber (right*)	3.12
3705103—1953 (left*)	7.32

FENDER SHIELD LOWER EXTENSION	
4594176—1949 to 52, B.S. 1008-61-62-69, metal (right*)	3.53
4561897—1949-50, B.S. 1208-69, rubber (right*)	1.07
4587727—1951-52, B.S. 1008-69, metal (right*)	3.83
4587731—1951-52, B.S. 1208-69, rubber (right*)	2.10
4566886—1949-50, B.S. 1208-69, rubber on rocker (right*)	1.07
4567431—1949 to 51, sta. wag., metal on rocker (right*)	2.63
4567431—1949-50, B.S. 1008-69, metal on rocker (right*)	2.63

FENDER CROWN MOLDING	
4561382—1949-50, B.S. 1008-1208-1069-1269 (right*)	1.80
4561382—1949 to 51, sta. wag. (right*)	1.80
4561492—1949-50, extension on rocker (right*)	1.03
4561492—1949 to 51, sta. wag., extension on rocker (right*)	1.03

REAR DOOR OUTER PANEL	
4571056—1949, B.S. 1061, lower (right*)	21.17
4174219—1949 to 52, B.S. 1069-1269 (right*)	15.20
4174402—1949 to 51, B.S. 1008-1208 (right*)	15.20
4175383—1949 to 52, B.S. 1062 (right*)	15.20
4191752—1953, 1069, 1269 (right*)	15.55
4191756—1953, sta. wag. (right*)	14.60

BODY SILL MOLDING	
3688947—1949 to 52 (left*)	4.02
3698437—1953 (left)	2.89

FRONT DOOR OUTSIDE LOCKING HANDLE	
4168322—1949 to 52, B.S. 1008-62-69-1208-69 (right*)	2.68
4168381—1949, B.S. 1061 (right*)	3.88
4150568—1953, 4 dr. (right*)	2.77
4150570—1953, sta. wag. (right*)	2.77

FRONT DOOR OUTER PANEL	
4562781—1949 to 52, B.S. 1069-1269 (right*)	15.20
4562869—1949 to 51, B.S. 1008-1208 (right*)	15.20
4581242—1949 to 52, B.S. 1062 (right*)	15.20

4571052—1949, B.S. 1061 (lower right*)	20.09
4596749—1953, 1069, 1269 (right*)	15.69
4601514—1953, sta. wag. (right*)	15.34
36 FRONT FENDER NAME PLATE (Deluxe)	
3692093—1949-50, GK, HK	.63
37 FRONT FENDER MOLDING	
3693873—1949-50, GK, HK	1.93
3695287—1951, JK (deluxe) (left*)	3.47
3700036—1952	1.84
3698359—1953 (left*)	1.58
38 PARKING LAMP ASSY.	
928541—1949	4.20
928560—1950	4.50
928693—1951 (left*)	5.00
928763—1952 (left*)	5.20
928476—1953	3.60
39 HEADLAMP DOOR	
5941285—1949 to 52	2.35
5943962—1953	2.65
40 SEALED BEAM UNIT	
193195—1940 to 53	1.40
41 HOOD FRONT EMBLEM	
3693312—1949-50	1.69
3699032—1951	1.82
3699646—1952	2.95
3702726—1953	4.25
42 REAR DOOR LOWER MOLDING	
4607722—1951, B.S. 1008-62-69	1.63
4607722—1952, B.S. 1062-69	1.63
4628188—1953, 1069WD (right*)	2.50
4599650—1953, sta. wag. (right*)	1.95
43 REAR DOOR EMBLEM	
4610435—1952, Ser. 1000, exc. sta. wag. (right*)	1.03
44 FENDER SHIELD	
4610435—1952, B.S. 1069 (right upper*)	1.03

45 REAR FENDER MOLDING	
4610265—1952, B.S. 1069	3.07
4603306—1953, 1069W (right*)	3.13
4604262—1953, 1062, 62F (right*)	3.13

Body Moldings, Wheels and Glass

*4-Door Bel Air Sedan
See Fig. 8*

1 HOOD ORNAMENT	
3701529—1953	4.25
2 COWL BELT	
4596460—1953 (right*)	2.23
3 WDSHD. REVEAL MLDG.	
4605763—1953, 1069, up. (right*)	2.52
4605765—1953, 1069, low. (right*)	.98
4 WDSHD. GLASS	
4612502—1953	61.95
5 FRONT DOOR DRIP MLDG.	
4596445—1953, front (right*)	.65
4596449—1953, rear (right*)	.82
6 VENT. ASSY.	
4614671—1953 (right*)	3.35
7 VENT. GLASS	
4599944—1953	4.05
8 VENT. DIV. MLDG.	
4151974—1953 (right*)	4.07
9 FRONT DOOR GLASS	
4599950—1953	10.25
4612511—1953, tinted	11.25
10 FRONT DOOR REVEAL MLDG.	
4603643—1953, front (right*)	7.90
4603631—1953, up. (right*)	2.80
4603793—1953, low. (right*)	3.50
11 CENTER PILLAR	
4564586—1953	.33

continued

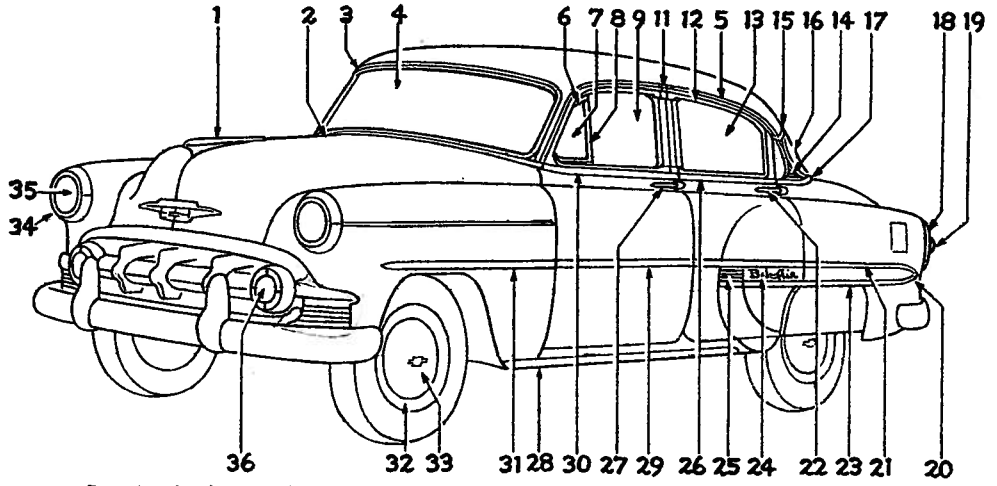

Fig. 8—Body Moldings, Wheels and Glass—1953—4 door Bel Air Sedan

* Opposite side one part number higher

CHEVROLET 1949 thru 1953 BODY PARTS

ALL BODY STYLES

Body Moldings, Wheels and Glass—continued

12 REAR DOOR REVEAL MLDG.	
4628184—1953, up. (right*)..	2.95
4628186—1953, low. (right*)..	3.35
4628182—1953, rear (right*)..	8.25
13 REAR DR. WINDOW GLASS	
4600533—1953	12.95
4611358—1953, tinted	11.95
14 REAR QTR. MLDG.	
4603611—1953, up. (right*)..	3.95
4595971—1953, rear (right*)..	2.25
15 BACK W/W REVEAL MLDG.	
4597325—1953, up. cor.	1.22
4614263—1953 (right*)	3.55
4614326—1953, side (right*)..	3.25
16 BACK W/W GLASS	
4616100—1953	29.75
4616101—1953, tinted	36.00
17 REAR QTR. BELT MLDG.	
4597201—1953 (right*)	2.48
18 TAIL LAMP DOOR	
5943401—1953	3.00
19 TAIL LAMP LENS	
5943403—1953, up. out.60
5944070—1953, up. in.25
5943406—1953, center65
5943404—1953, lower60
20 REAR FENDER V MLDG.	
4606007—1953	2.10
21 REAR FENDER MLDG.	
4603304—1953, up. (right*)..	2.65
4603607—1953, low. (right*)..	3.35
22 REAR DR. HANDLE	
4150568—1953	2.77
23 REAR DR. MLDG.	
4603401—1953, up. (right*)..	1.30
4602694—1953, low. (right*)..	5.33

24 FENDER EMBLEM	
4612776—1953	3.50
25 REAR DR. SHIELD MLDG.	
4597201—1953 (right*)	2.48
26 REAR DR. BELT MLDG.	
4628188—1953 (right*)	2.50
27 FRONT DR. HANDLE	
4150568—1953	2.77
28 SILL MLDG.	
3698437—1953 (left*)	2.89
29-30 FRONT DOOR BELT	
4613754—1953 (right*)	2.22
31 FRONT FENDER MLDG.	
3698359—1953 (left*)	1.58
32 WHEEL	
3687980—1953	10.78
33 HUB CAP	
3698555—1953	2.84
WHEEL DISC RING	
986656—1953	19.75
34 HEADLAMP DOOR	
5943962—1953	2.65
35 SEALED BEAM UNIT	
193195—1953	1.40
36 PARKING LAMP ASSY.	
928476—1953	3.60
PARKING LAMP LENS	
5943220—195345
LENS GASKET	
5943221—195320
Body Moldings, Wheels and Glass	
<i>Bel Air—2 door & Sport Coupe</i>	
See Fig. 9	
1 HOOD ORNAMENT	
3701529—1953	4.25

2 COWL BELT MLDG.	
4596460—1953	2.2
3 WDSHD., REVEAL MLDG.	
4605763—1953, 2-d. up. (right*)	2.5
4608657—1953, spt. cpe., up...	3.8
4605765—1953, 2-d. low. (right*)	.9
4597893—1953, spt. cpe., side (right*)	3.9
4 WDSHD. GLASS	
4601260—1953, 2-d.	44.3
4598909—1953, spt. cpe.	42.6
4612502—1953, 2-d. tinted....	61.9
4615797—1953, spt. cpe., tinted	67.5
5 VENT ASSY.	
4616518—1953, 2-d. (right*)..	9.7
4606165—1953, spt. cpe. (right*)	36.8
6 VENT. DIV. CHAN.	
4596421—1953, 2-d. (right*)..	.9
4598524—1953, spt. cpe. (right*)	1.8
7 DOOR W/W REVEAL MLDG.	
4603643—1953, 2-d., front (right*)	7.9
4611196—1953, spt. cpe., low. (right*)	5.9
8 DOOR BELT MLDG.	
4621336—1953, 2-d. (right*)..	2.4
4613752—1953, spt. cpe. (right*)	2.4
4603087—1953, 2-d. low. (right*)	2.3
9 DOOR HANDLE	
4150568—1953, 2-d. (right*)..	2.7
4150572—1953, spt. cpe. (right*)	2.7
10 DOOR W/W GLASS	
4595550—1953, 2-d.	13.4
4602629—1953, spt. cpe.	12.6
11 REAR QTR. GLASS	
4599419—1953, 2-d.	12.2
4600839—1953, spt. cpe.	8.4
DOOR GLASS CHAN.	
4601065—1953, spt. cpe., up. & rear (right*)	13.3
12 QTR. W/W REVEAL MLDG.	
4617002—1953, 2-d., up. (right*)	3.1
4617070—1953, 2-d., low. (right*)	3.7
4617088—1953, 2-d., rear (right*)	3.7
12 QTR. W/W REVEAL MLDG.	
4611961—1953, spt. cpe., low. (right*)	3.7
4611959—1953, spt. cpe., rear (right*)	1.7
4611963—1953, spt. cpe., at roof (right*)	1.3
QTR. W/W HEADER MLDG.	
4616705—1953, 2-d. front (right*)	1.5

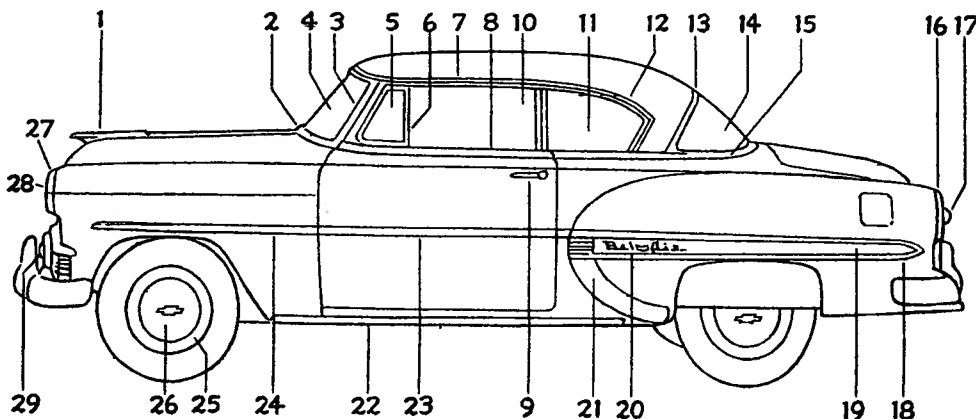

Fig. 9—Body Moldings, Wheels and Glass 1953—Bel Air models

* Opposite side one part number higher

BODY PARTS 1949 thru 1953 CHEVROLET ALL BODY STYLES

<p>4617090—1953, 2-d., rear (right*) 3.15</p> <p>3 BACK W/W MLDG. 4614263—1953, 2-d., low. 3.55 4614326—1953, 2-d., side (right*) 3.25 4599525—1953, spt. cpe., up. . . 3.75 4601533—1953, spt. cpe., low. (right*) 2.88 4615906—1953, spt. cpe., low. cor. (right*) 1.30</p> <p>4 BACK W/W GLASS 4616100—1953, 2-d. 29.75 4618686—1953, spt. cpe. 32.50 4616101—1953, 2-d., tinted... 36.00 4618717—1953, spt. cpe., tinted 38.75</p> <p>5 REAR QTR. BELT MLDG. 4597197—1953, 2-d. (right*).. 3.95 4600270—1953, spt. cpe. (right*) 3.65</p> <p>6 TAIL LAMP DOOR 5943401—1953, all 3.00</p> <p>7 TAIL LAMP LENS 5943403—1953, up. out.60 5944070—1953, up. in.25 5943406—1953, center65 5943404—1953, lower60</p> <p>8 REAR FENDER V MLDG. 4606007—1953, all 2.10</p> <p>9 REAR FENDER MLDG. 4603300—1953, up. front (right*) 3.60 4603302—1953, low. front (right*) 4.35</p> <p>0 EMBLEM ("Bel-Air") 4612776—1953 3.50</p> <p>1 FENDER SHIELD 4603388—1953 (right*) 8.17</p> <p>2 SILL MLDG. 3698437—1953 (left*) 2.89</p> <p>3 DOOR MLDG. 4603087—1953, lower 2.35</p>	<p>24 FRONT FENDER MLDG. 3698359—1953 (left*) 1.58</p> <p>25 WHEEL 3687980—1953 10.78</p> <p>26 HUB CAP 3698555—1953 2.84</p> <p>WHEEL DISC RING 986656—1953 19.75</p> <p>27 HEADLAMP DOOR 5943962—1953 2.65</p> <p>28 SEALED BEAM UNIT 193195—1953 1.40</p> <p>29 PARKING LAMP ASSY. 928476—1953 3.60</p> <p>PARKING LAMP LENS 5943220—195345</p> <p>LENS GASKET 5943221—195320</p>	<p>5 WINDSHIELD REVEAL MOLDING 4560823—1949 to 52 (right upper*) 3.02 4560942—1949 to 52 (right lower corner*)98 4562378—1949 to 52 (right lower*) 2.13</p> <p>6 DOOR VENTILATOR GLASS 4561184—1949 to 52 4.20</p> <p>7 RAIN DEFLECTOR 3695745—1950-51, Bel Air (left*) 3.45 4614522—1952, Bel Air (right*) 3.73</p> <p>8 DOOR GLASS DIVISION CHANNEL 4168059—1949 to 52, glass run upper front channel57 4180930—1949 to 52, less glass run upper front channel (right*) 3.18 4180809—1950 to 52, scalp channel, outer (left*)65</p> <p>9 DOOR VENTILATOR GLASS CHANNEL 4168055—1949 to 52 (right*).. 5.92</p> <p>10 DOOR GLASS 4560906—1949 to 52 12.60</p> <p>11 DOOR BELT UPPER MOLDING 4565181—1949 to 52 (right*).. 2.18</p> <p>12 DOOR BELT LOWER MOLDING 4560098—1949-50 2.10 4587007—1951-52 2.90</p> <p>13 SCALP MOLDING FITS OVER DRIP MOLDING 4578709—1950 to 52, Bel Air (right*) 1.90 4580173—1950 to 52, Bel Air (right*) 1.68</p> <p>13 MOLDING UNIT, W/S HEADER CONSISTS OF DRIP MLDG. AND SCALPS 3695198—1950 to 52, Bel Air.. 5.17</p>
---	---	---

Body Moldings, Wheels and Glass

*Cabriolet and Bel Air
See Fig. 10*

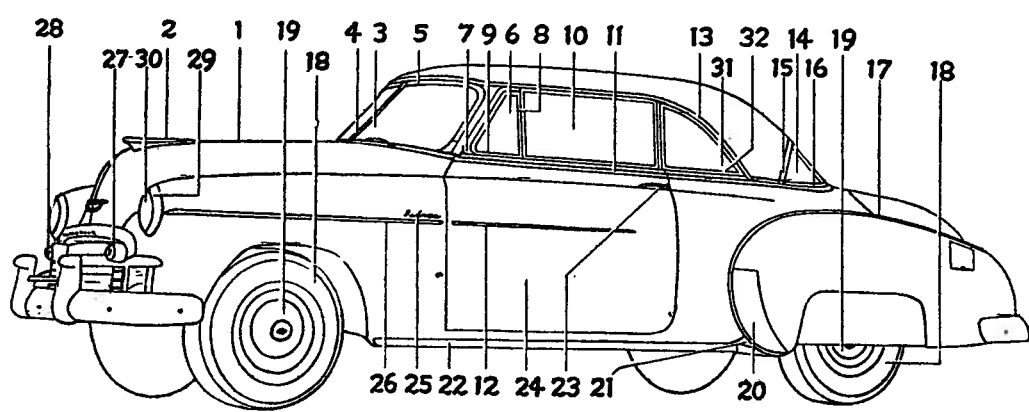

Fig. 10—Body Moldings, Wheels and Glass
* Opposite side one part number higher

continued

CHEVROLET 1949 thru 1953 BODY PARTS

ALL BODY STYLES

Body Moldings, Wheels and Glass—continued

3695199—1950 to 52, Bel Air (left*)	3.17
14 BACK WINDOW GLASS	
4117576—1941 to 52, CBL	5.15
4597407—1951-52, CBL	10.18
4577106—1950 to 52, Bel Air (right side*)	7.51
4577108—1950 to 52, Bel Air, center	13.15
15 BACK WINDOW GLASS REVEAL MOLDING, BEL AIR	
4578936—1950 to 52 (right upper*)	2.47
4579092—1950 to 52 (right lower front*)	1.03
4586977—1950 to 52 (right lower rear*)	2.85
15 BACK WINDOW GLASS FRAME	
4567262—1949-50, CBL	5.47
15 BACK WINDOW DIVISION MOLDING, BEL AIR	
4578502—1950 to 52, outer95
4591242—1950 to 52, inner (right*)	2.08
15 BACK WINDOW GLASS RUBBER CHANNEL, BEL AIR	
4592650—1950, with 2 division channels	10.75
4592650—1951-52, with 2 division channels	10.75
16 REAR QUARTER BELT MOLDING	
4579792—1949 to 52 (right*) ..	3.17
4579793—1949 to 52, CBL (left)	3.17
17 FENDER CROWN MOLDING	
4561542—1949-50 (right rear*)	3.45

3695257—1951, Ser. 1000	2.57
4614937—1952	3.28
986702—1952	8.05
18 FRONT AND REAR WHEEL	
3687980—1949 to 52	10.78
19 WHEEL HUB CAP	
3694318—1949-50	2.68
3698555—1951-52	2.84
20 FENDER SHIELD	
4561729—1949-50 (right*)	6.87
4589001—1951 (right*)	7.93
4610633—1952 (right*)	2.93
21 FENDER SHIELD EXTENSION ON ROCKER	
4567431—1949-50 (right*)	2.63
22 BODY SILL MOLDING	
3688947—1949 to 52 (left*) ...	4.02
23 DOOR OUTSIDE LOCKING HANDLE	
4168322—1949 to 52 (right*) ..	2.68
24 DOOR OUTER PANEL	
4564876—1949 to 52 (right*) ..	18.18
25 FRONT FENDER NAME PLATE	
3692093—1949-5063
26 FRONT FENDER MOLDING	
3693873—1949-50, GK, HK ...	1.93
3695287—1951, JK (left*)	3.47
3700036—1952, KK	1.84
27 PARKING LAMP	
928541—1949	4.20
928560—1950	4.50
928698—1951 (left*)	5.00
928763—1952 (left*)	5.20
28 PARKING LAMP LENS	
5938155—194955
5939299—195055
5939934—195145
5943032—195282

28 PARKING LAMP LENS GASKET	
5938157—1949-5010
5939935—195115
5943033—195225
28 PARKING LAMP WIRE HARNESS	
5943620—1949 to 5280
29 HEADLAMP DOOR	
5941285—1949 to 52	2.85
30 SEALED BEAM UNIT	
193195—1940 to 52	1.40
31 QUARTER WINDOW GLASS	
4562415—1949 to 52	8.15
32 QUARTER WINDOW REVEAL MOLDING	
4610955—1950 to 52, Bel Air (right upper*)	6.25
4586790—1950 to 52, CBL strip outer panel (right*)	2.75
4610955—1952, Bel Air (right upper*)	6.25
32 QUARTER WINDOW GLASS WEATHERSTRIP	
4562592—1949 to 52 (right*) ..	1.85
HOOD FRONT EMBLEM	
3693312—1949-50	1.65
3699032—1951	1.85
3699646—1952	2.95

Body Sheet Metal and Fuel Tank

Cabriolet and Bel Air
See Fig. 11

1 COWL ASSY. W/DASH	
4582461—1949-50, CBL	107.71
4580717—1950, Bel Air	96.77
4613226—1951-52, CBL	102.50
4613227—1951-52, Bel Air	96.77
4624685—1953, 1067	105.00
4624512—1953, 1037	99.75
2 COWL SIDE PANEL	
4562034—1949 to 52 (right*) ..	5.95
4593547—1953 (right*)	5.95
COWL PANEL REINFORCEMENT W/ANCHOR PLATE	
4566366—1950 to 52 (right*) ..	1.10
4619977—1953 (right*)	1.00
WINDSHIELD UPPER FRAME	
4568737—1949-50, CBL, inner.	5.43
4564470—1949 to 52, CBL, outer	9.23
4580428—1950, Bel Air, inner.	4.89
4577408—1950 to 52, Bel Air, outer	7.06
4593466—1951-52, CBL, inner.	5.43
4593462—1951-52, Bel Air, inner	4.89
4593462—1951-52, Bel Air, inner	4.89

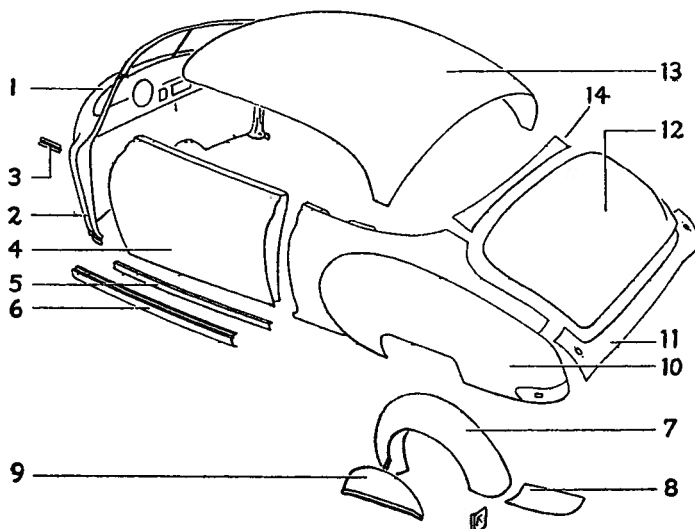

Fig. 11—Body Sheet Metal and Fuel Tank

* Opposite side one part number higher

BODY PARTS 1949 thru 1953 CHEVROLET

ALL BODY STYLES

4600846—1953, 1067 inner....	4.95
4600849—1953, 1037 inner....	5.14
COWL SIDE RAIL	
4564042—1949 to 52, CBL (right*)	7.06
4579529—1950 to 52, Bel Air (right*)	4.62
4598719—1953, 1067 (right*)..	5.50
4598717—1953, 1037 (right*)..	4.35
DOOR OUTER PANEL	
4564876—1949 to 52, CBL, Bel Air (right*)	18.18
4191754—1953, all (right*)..	18.18
DOOR INNER ROCKER PANEL	
4580153—1949 to 52 (right*)..	3.26
4594484—1953 (right*)	3.26
DOOR OUTER ROCKER PANEL	
4169448—1949 to 52 (right*)..	10.29
4191114—1953 (right*)	13.85
WHEEL HOUSE PANEL	
4559484—1949-50 (right*)	12.49
4614707—1951-52 (right*)....	12.49
4603564—1953, 1067 (right*)..	13.20
4603562—1953, 1037 (right*)..	13.20
TRAVEL DEFLECTOR	
4562723—1949-50 (right*)92
458247—1951-52 (right*)92
WHEEL HOUSE ACCESS HOLE COVER	
4571663—1949-50	1.90
4591011—1951-52 (right*) ...	1.90
REAR QUARTER SIDE OUTER PANEL	
4566982—1949, CBL (right*) .	65.06
4584203—1950, CBL (right*) .	65.06
4582252—1950, Bel Air (right*)	57.12
4190946—1951-52, CBL (right*)	70.72
4190948—1951-52, Bel Air (right*)	62.19
4197306—1953, 1067 (right*)..	72.45
4197300—1953, 1037 (right*)..	64.00
REAR QUARTER SIDE INNER PANEL	
4564153—1949 to 52, CBL (right*)	5.69
4615582—1950 to 1952, Bel Air (right*)	15.75
4603083—1953, 1067 (right*)..	5.69
4603081—1953, 1037 (right front*)	9.90
4603298—1953, 1037 (right rear*)	1.65
REAR QUARTER SIDE OUTER PANEL	
4559871—1949, CBL (right*) .	32.26
4584348—1950, CBL (right*) .	34.98
4582259—1950, Bel Air (right*)	30.62
4593060—1951-52, CBL (right*)	34.98
4593061—1951-52, Bel Air (right*)	34.98
4197308—1953, 1067 (right*)..	34.98
4197302—1953, 1037 (right*)..	33.85

11 BODY BACK LOWER PANEL	
4584491—1949-50, CBL Bel Air	9.32
4588360—1951-52, Styleline ...	7.34
4596662—1953	5.90
12 REAR COMPARTMENT LID	
4180876—1949 to 52, CBL, Bel Air	43.14
4592888—1953	44.75
13 TURRET TOP ROOF PANEL	
4611080—1950 to 52, Bel Air..	92.35
4615515—1953, 1037	51.52
14 DECK FRONT PANEL	
4559851—1949 to 52, CBL	5.26
4576533—1950 to 52, Bel Air..	4.62
4593646—1953, 1067	5.48
4595889—1953, 1037	5.26
REAR WHEEL COVER PANEL WHEEL SHIELD	
3693334—1949-50 (right*)	7.32
3695982—1951-52	7.32
3705103—1953 (right*)	7.32
GASOLINE TANK	
3694851—1949 to 52	18.18
3702862—1953	18.18

4611963—1953, 1037 (right at roof*)	1.30
4612685—1953, 1067 (right*)..	5.50
WINDOW GLASS	
4562415—1949 to 52	8.12
2 GLASS WEATHERSTRIP	
4562592—1949 to 52 (right*)..	1.87
4602953—1953, 1067 (right front*)	1.87
4602583—1953, 1037 (right front*)	1.87
4604327—1953, 1037 (right up. inner*)	1.15
4607180—1953, all (low. front)	.45
3 WINDOW REGULATOR	
4562704—1949 to 52 (right*)..	4.40
4598503—1953 (right*)	4.40
4 UPPER SASH CHANNEL	
4170830—1949 to 52	8.98
4151675—1953, 1067	8.98
4151694—1953, 1037	10.40
4 LOWER SASH CHANNEL	
4177727—1949 to 52 (right*)..	17.20
4150856—1953, 1067 (right*)..	17.20
4150642—1953, 1037 (right*)..	16.75
5 WINDOW GLASS BUMPER	
4132055—1946 to 52, upper....	.06
4131772—1942 to 52, lower....	.02
4599954—1953, 106706
6 WINDOW GUIDE	
4562794—1940 to 52, CBL (right*)	3.77
4578740—1950 to 52, Bel Air (right*)	3.18
4601059—1953, 1067 (right*)..	4.05
4601562—1953, 1037 (right*)..	3.77
7 WINDOW HINGE	
4562209—1949 to 52 (right*)..	2.09
4606826—1953 (right*)	2.90
8 WINDOW HINGE ADJUSTING PLATE	
4562263—1949 to 52 (right*)..	.85

Rear Quarter Window

Cabriolet and Bel Air

See Fig 12

WINDOW REVEAL MOLDING	
4610955—1950 to 52, Bel Air, upper (right*)	6.29
4586790—1950 to 52, CBL, outer panel chrome (right*)	2.75
4611961—1953, 1037 (right low*)	3.75
4611959—1953, 1037 (right rear*)	1.75

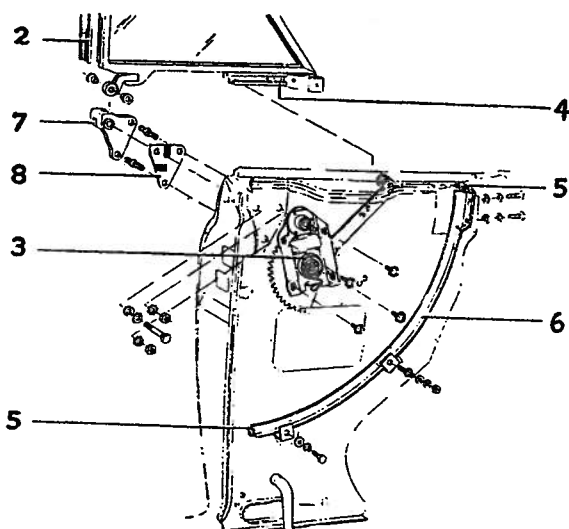

Fig. 12—Rear Quarter Window, Bel Air & Cabriolet

* Opposite side one part number higher

CHEVROLET 1949 thru 1953 BODY PARTS

ALL BODY STYLES

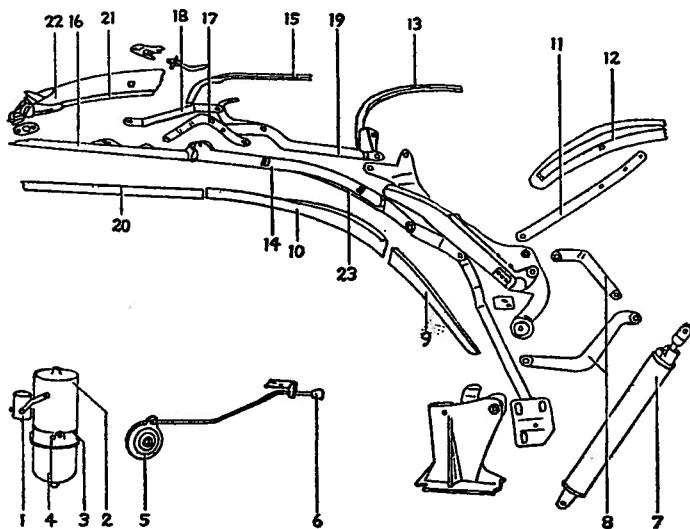

Fig. 13—Hydro-Electric Power Top
(Left Side Part Numbers Shown) Cabriolet

Hydro-Electric Power Top

Cabriolet

See Fig. 13

1 SOLENOID	
001463—1946 to 50.....	2.83
4594599—1951-52	3.32
4619381—1953	3.32
2 MOTOR	
1108572—1949-50	25.71
4170976—1949	29.34
3702968—1951-53	21.35
MOTOR, W/PUMP	
4594191—1951-52	32.60
4603742—1953	32.60
3 PUMP	
4162272—1946 to 49.....	21.58
5453599—1949 to 52	19.95
3701147—1951 to 53 (hyd.)...	8.00
4 RESERVOIR	
5453509—1946 to 50.....	2.30
3698104—1951-53	2.52
5 CONTROL VALVE	
4149731—1946 to 52.....	7.60
6 CONTROL VALVE KNOB	
4564065—1949	1.60
4582147—1950	1.63
7 HYDRAULIC CYLINDER LIFT	
4567324—1949-50	12.68
4600036—1951-52	12.68
4615148—1953	12.75
8 UPPER LINK, NO. 1 BOW	
4567171—1949-50 (right*) ...	1.84
4590744—1951-52 (right*) ...	1.84
8 LOWER LINK, NO. 1 BOW	
4567210—1949-50 (right and left)	2.52

4590743—1951-52 (right and left)	2.52
9 SIDE ROOF RAIL REAR WEATHERSTRIP	
4583691—1949 to 52 (right*) ..	2.83
4614905—1953 (right*)	2.00
10 SIDE ROOF RAIL CENTER WEATHERSTRIP	
4583687—1949 to 52 (right*)..	3.90
4614800—1953 (right*)	3.90
11 REAR BOW SLAT IRON (Right and Left)	
4565305—1949	3.08
4590746—1950	2.07
4590746—1951-52	2.07
12 REAR BOW	
4601337—1949-50	7.77
4601337—1951-52	7.77
4615475—1953	12.95
13 CENTER BOW, NO. 1	
4565300—1949-50	7.27
4590751—1951-52	7.27
4614592—1953	7.27
14 SIDE ROOF REAR RAIL	
4567958—1949 (right*)	17.50
4590754—1950 to 52 (right*)..	13.42
4614982—1953 (right*)	13.75
15 AUXILIARY BOW	
4565105—1949-50	5.15
4590736—1951-52	5.15
4596782—1953	5.15
16 FRONT SIDE ROOF RAIL, WITH MALE HINGE	
4567960—1949 (right*)	8.83
4590756—1950 to 52 (right*)..	7.95
4614966—1953 (right*)	7.95
17 AUXILIARY BOW LINK	
4580754—1949 (right*)	17.89

18 UPPER LINK, BOW NO. 1	
4567171—1949-50 (right*) ...	1.84
4590744—1951-52 (right*) ...	1.84
19 SIDE ROOF RAIL CONTROL LINK ASSEMBLY	
4567247—1949 (right*)	10.00
4580753—1949 (right*)	17.00
4586503—1950 (right*)	10.00
4590762—1951-52 (right*) ...	11.00
4616459—1953 (right*)	9.00
20 SIDE ROOF RAIL FRONT WEATHERSTRIP	
4583685—1949 to 52 (right*)..	2.00
4615003—1953 (right*)	3.00
20 WEATHERSTRIP RETAINER	
4564657—1949 to 52 (right*)..	3.00
4614992—1953 (right*)	3.00
21 FRONT ROOF RAIL WEATHERSTRIP	
4563765—1949 to 52 (right*)..	1.00
4566232—1949 to 52, on w/shield header	2.00
4191680—1953 (center)	1.00
22 FRONT ROOF RAIL, W/INNER PANEL AND LOCK	
4590772—1949 to 52	30.00
4602575—1953	30.00
23 ROOF SIDE REAR RAIL, W/REAR CONTROL LINK AND PLATE	
4567958—1949 (right*)	17.00
4590754—1950 to 52 (right*)..	13.00
4614982—1953 (right*)	13.00

Front Door

Cabriolet and Bel Air

See Fig. 14

1 DOOR	
4184848—1949 to 52, CBL, Bel Air (right*)	51.00
4191122—1953 (right*)	51.00
2 UPPER AND LOWER DOOR HINGE	
4559290—1949 to 52	2.00
4191681—1953 (right box*) up.	3.00
4191683—1953 (right strap*) up.	3.00
4150328—1953 (right box*) low.	2.00
4191685—1953 (right strap*) low.	2.00
3 DOOR CHECK LINK	
4600309—1949 to 52	
4 DOOR WINDOW REGULATOR	
4561302—1949 to 52 (right*)..	6.00
4596388—1953 (right*)	6.00
5 DOOR LOCK	
4560814—1949 to 51, 1st type (right*)	4.00
4592731—1951-53, 2nd type (right*)	4.00
6 DOOR WINDOW REGULATOR CAM	
4074627—1949 to 52	
4073936—1953	

* Opposite side one part number higher

BODY PARTS 1949 thru 1953 CHEVROLET

ALL BODY STYLES

DOOR LOCK REMOTE CONTROL	
4562601—1949 to 52 (right*)..	.97
4569559—1953 (right*)95
DOOR LOCK REMOTE CONTROL ROD	
4562498—1949 to 52, CBL, Bel Air17
4597462—1953 (right*)17
DOOR VENTILATOR GLASS	
4561184—1949 to 52, CBL, Bel Air	4.20
4602799—1953	4.05
DOOR VENTILATOR ASSY.	
4582118—1949-50, CBL (right*)	41.00
4582118—1950 to 52, Bel Air, 1st type (right)	41.00
4582119—1950 to 52, CBL, Bel Air, 1st type (left).....	41.00
4613252—1951 to 52, CBL, Belair, 2nd type (right*)...	36.80
4606163—1953, 1067 (right*)..	36.80
4606165—1953, 1037 (right*)..	36.80
GLASS DIVISION CHANNEL	
4180930—1949 to 52, CBL, Bel Air (right*)	3.18
4191710—1953 (right*)	3.05
DIVISION CHANNEL WEATHERSTRIP	
4180811—1950 to 52, CBL, Bel Air (right*)	1.02
4191700—1953 (right*)	1.02
DOOR WINDOW OUTER WEATHERSTRIP	
4102157—1949 to 5397
DOOR BOTTOM WEATHER-STRIP	
4578148—1949 to 52 (right*)..	1.63
4620562—1953 (right*)	3.00
DOOR OPENING WEATHER-STRIP	
3692045—1949 to 53 (A.R.), per ft.13
4606455—1949 to 52, lock pillar (right*)	1.60
4620568—1953, lock pillar (right*)	1.05

15 DOOR GLASS RUN CHANNEL	
4556937—1949 to 52, CBL, Bel Air	2.38
4608082—1953 (right*)	2.17
GLASS RUN CHANNEL WEATHERSTRIP (At lock)	
4586795—1950 to 52, CBL, Bel Air57
See item 15 for '53	
16 DOOR VENTILATOR WEATHERSTRIP	
4169182—1949-50, CBL, Bel Air (right*)	3.68
4180805—1951-52, CBL, Bel Air (right*)	4.13
4580139—1949, CBL, front re- tainer22
4580140—1949, CBL, front re- tainer22
4191702—1953 (right*)	4.13
17 DOOR LOCK STRIKER	
4604440—1949 to 52	1.22
4604438—1953 (right*)	1.23
18 DOOR INSIDE LOCK TO KNOB ROD	
4560512—1949 to 52, CBL, Bel Air (right*)13
4603361—1953 (right*)13
19 DOOR WINDOW REGULATOR HANDLE	
4564255—1949	1.62
4582152—1950	1.62
4601168—1951-52	1.62
4619387—1953	1.50
20 DOOR GLASS LOWER SASH CHANNEL CAM	
4099974—1949 to 5340
21 DOOR LOCK INSIDE HANDLE	
4564254—1949 to 52	1.02
3703632—1953	1.02
22 DOOR GLASS LOWER SASH CHANNEL	
4613791—1949 to 52, CBL, Bel Air (right*)	4.20
4598524—1953 (right*)	1.85
23 DOOR GLASS SASH CHANNEL	
4560812—1949 to 51, 1st type, upper and rear (right*)	15.06

4596366—1951-52, 2nd type, up- per (right*)	13.34
4601065—1953, upper and rear (right*)	13.34

Front Door Assembly

*2-4 Door Sedans, Station Wagons and Coupes
See Fig. 15*

1 FRONT DOOR

4184846—1949 to 52, B.S. 1008- 1208 (right*)	45.69
4184844—1949 to 52, B.S. 1069- 1269 (right*)	46.51
4184837—1949 to 52, B.S. 1062 (left)	43.42
4184838—1949 to 52, B.S. 1007- 1207 (right*)	51.72
4184840—1949 to 52, B.S. 1011- 1211 (right*)	51.72
4184842—1949 to 52, B.S. 1027- 1227-27B (right*)	51.83
4572231—1949, B.S. 1061 (right*)	157.37
4184836—1949 to 52, B.S. 1062 (right)	43.42
4191744—1953, 2-dr. & cpes. (right*)	52.80
4191746—1953, 4-dr. (right*)..	47.18
4191748—1953, sta. wag. (right*)	44.48

2 DOOR UPPER AND LOWER HINGE

4559290—1949 to 52.....	2.43
4191681—1953, up. (right*) box	3.75
4191683—1953, up. strap (right*)	3.95
4150328—1953, low. box	2.95
4191685—1953, low. strap	2.35

3 CHECK LINK

4600309—1949 to 5352
--------------------------	-----

4 DOOR WINDOW REGULATOR

4559558—1949 to 52, B.S. 1008- 69-1208-69-71 (right*)	5.38
4561302—1949 to 52, B.S. 1007- 1207-1011-1211 (right*) ...	6.07
4564801—1949, B.S. 1061 (right*)	5.38
4564588—1949 to 52, B.S. 1062 (right*)	5.62
4561302—1949 to 52, B.S. 1027- 1227-1227B (right*)	6.07
4564588—1949 to 52, B.S. 1062 (right*)	5.62
4596388—1953 (right*)	6.07

5 FRONT DOOR LOCK

4560814—1949 to 51, 1st type (right*)	4.83
4592731—1951 to 53, 2nd type (right*)	4.83

6 DOOR GLASS LOWER SASH CHANNEL CAM

4099974—1949 to 5340
--------------------------	-----

continued

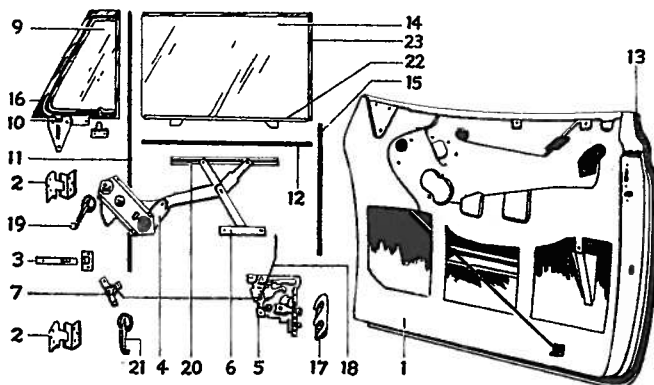

**Fig. 14—Front Door (Left Side Part Numbers Shown)
Cabriolet & Bel Air**

* Opposite side one part number higher

CHEVROLET 1949 thru 1953 BODY PARTS

ALL BODY STYLES

Front Door Assembly— continued

7 DOOR LOCK REMOTE CONTROL	
4562601—1949 to 52 (right*)	.97
4563368—1949 to 52, sta. wag. (right*)	.97
4569559—1953 (right*)	.95
8 REMOTE CONTROL CONNECTING LINK	
4566752—1949, B.S. 1061 (right*)	.13
4561811—1949 to 52, B.S. 1007-11-1207-11-27-27B (right*)	.17
4562596—1949 to 52, B.S. 1008-69-1208-69 (right*)	.13
4562610—1949 to 52, B.S. 1062 (right*)	.13
4597458—1953, 2-dr. & cpes. (right*)	.17
4597460—1953, 4-dr. (right*)	.18
4601400—1953, sta. wag. (right*)	.17
9 DOOR VENTILATOR GLASS	
4560574—1949 to 52, Fleet Line	3.92
4561275—1949 to 52, Style Line	4.20
4599944—1953	4.05
10 DOOR VENTILATOR ASSEMBLY	
4611127—1949 to 52, exc. Fleet Line (right*)	9.50
4561293—1949 to 52, Fleet Line (right*)	12.65
4616518—1953 (right*)	9.72
11 GLASS DIVISION CHANNEL	
4604076—1949, sta. wag., 1st type (right*)	4.33
4574332—1949, B.S. 1211-27-27B-69-71 (right*)	3.55
4593126—1949, B.S. 1007-08, 1st type (right*)	3.55
4574333—1949, B.S. 1011-27-69, 1st type (right*)	3.55
4574327—1949, B.S. 1207-08, 1st type (right*)	3.55
4593126—1949, B.S. 1007-08, 2nd type (right*)	3.55
4574327—1949, B.S. 1207-08, 2nd type (right*)	3.55
4604076—1949-51, B.S. 1061-1062, 2nd type (right*)	4.33
4574333—1949, B.S. 1011-27-69, 2nd type (right*)	3.55
4582182—1950, B.S. 1011-27-69-1211-27-27B-69-71 (right*)	3.55
4582184—1950, Fleet Line (right*)	3.55
4151738—1951-52, B.S. 1011-27-69-1211-27-27B-69-71 (right*)	4.07
4593126—1951-52, Fleet Line (right*)	3.55
4151974—1953 (right*)	4.07
12 DOOR WINDOW OUTER WEATHERSTRIP	
4102157—1949 to 53	.97

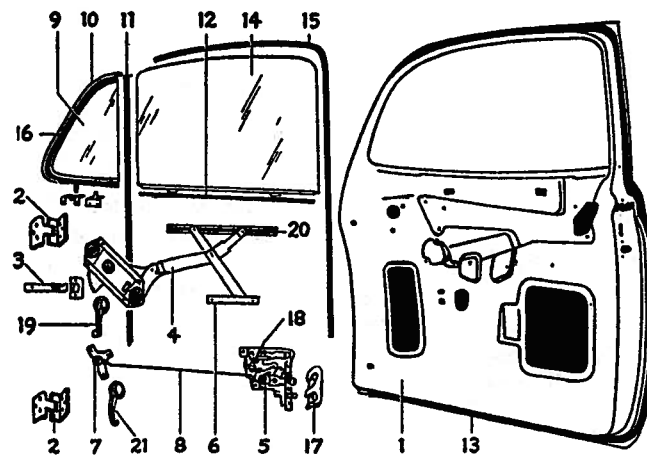

Fig. 15—Front Door—Typical of all 2-4 Door

13 DOOR BOTTOM WEATHERSTRIP	
4578148—1949 to 52 (right*)	1.63
DOOR OPENING WEATHERSTRIP	
3692045—1949 to 53 (A.R.), per ft.	.13
14 DOOR GLASS	
4559940—1949 to 52, B.S. 1011-1211	13.68
4561192—1949 to 52, B.S. 1007-1207	12.60
4559295—1949 to 52, B.S. 1069-1269-71	10.65
4559951—1949 to 52, B.S. 1027-1227-27B	13.37
4560558—1949 to 52, B.S. 1008-1208	9.72
4566721—1949 to 52, B.S. 1062	9.69
4566722—1949, B.S. 1061	9.43
4595550—1953, 2-dr. & cpes.	13.40
4599950—1953, 4-dr.	10.25
4603203—1953, 1062, 62F	9.85
4603297—1953, 1262F	8.08
15 GLASS RUN CHANNEL	
4045914—1949 to 53	1.85
16 VENTILATOR WEATHERSTRIP	
4168194—1949 (right*)	1.42
4151480—1950 to 52 (right*)	1.70
4191718—1953 (right*)	1.70
VENTILATOR RETAINER	
4151736—1949 to 52, Fleet Line (right*)	4.07
17 LOCK STRIKER	
4604440—1949 to 52 (right*)	1.22
4604438—1953 (right*)	1.23
18 INSIDE LOCK TO KNOB ROD	
4563262—1949 to 52, B.S. 1062 (right*)	.13
4566912—1949, B.S. 1061 (right*)	.13
4560512—1949 to 52 (right*)	.13
4595346—1953, 2-dr. & cpes. (right*)	.13
4598664—1953, 4-dr. (right*)	.13
4603603—1953, sta. wag. (right*)	.13

18 INSIDE LOCKING KNOB	
4568396—1949, Ser. 1200	1
4568395—1949, Ser. 1000	1
4568395—1950 to 52, sta. wag.	1
4611913—1953, 1069, grey	1
4624121—1953, 1262F, green	1
19 WINDOW REGULATOR HANDLE	
4564255—1949, Ser. 1000, exc. sta. wag.	1
4564255—1949, Ser. 1200	1
4572295—1949, sta. wag.	1
4582152—1950, Ser. 1000	1
4582151—1950, Ser. 1200	1
4582153—1950, sta. wag.	1
4601168—1951-52, Ser. 1000	1
4601170—1951-52, sta. wag.	1
4594189—1951-52, Ser. 1200	1
4619387—1953	1
20 DOOR GLASS LOWER SASH CHANNEL CAM	
4099974—1949 to 53, cut to size	
21 DOOR LOCK INSIDE HANDLE	
4564254—1949 to 52	1
4572980—1949 to 52, sta. wag.	1
3703632—1953	1

Rear Door

4-Door Sedans and Station Wagons
See Fig. 16

1 REAR DOOR	
4184858—1949 to 52, B.S. 1069-1269 (right*)	49
4184862—1949 to 52, B.S. 1062 (right*)	50
4184860—1949 to 52, B.S. 1008-1208 (right*)	49
4572300—1949, B.S. 1061 (right*)	124
4199094—1953, sdn. (right*)	49
4191174—1953	48
2 WINDOW REGULATOR	
4561640—1949 to 52, B.S. 1008-69-1208-69 (right*)	4

* Opposite side one part number higher

BODY PARTS 1949 thru 1953 CHEVROLET

ALL BODY STYLES

4563194—1949 to 52, B.S. 1061-1062 (right*)	4.57
4595036—1953, sdn. (right*)..	5.35
4600171—1953, sdn. (right*)..	5.35
DOOR LOWER HINGE	
4559314—1949 to 52, B.S. 1008-62-69-1208-69 (right*)	2.85
4565736—1949, B.S. 1061 (right*)	5.40
4595624—1953	2.91
LOCK REMOTE CONTROL CONNECTING ROD	
4562594—1949 to 52, B.S. 1069-1269 (right*)13
4562648—1949 to 52, B.S. 1062 (right)17
4564987—1949 to 52, B.S. 1062 (left)13
4566831—1949, B.S. 1061 (right*)13
4572892—1949 to 52, B.S. 1008-1208 (right*)18
4601398—1953, sdn. (right*)..	.13
4601400—1953, sta. wag. (right*)17
LOCK REMOTE CONTROL	
4562601—1949 to 52 (right*)97
4563368—1949 to 52, B.S. 1061-1062 (right*)97
4596423—1953 (right*)97
DOOR LOCK	
4560816—1949 to 51, 1st type (right*)	5.12
4592733—1951 to 53, 2nd type (right*)	5.12
DOOR UPPER HINGE	
4559411—1949 to 52, B.S. 1008-62-69-1208-69 (right*)	2.85
4565792—1949, B.S. 1061 (right*)	3.35
4595546—1953	2.91

8 WINDOW REGULATOR CAM	
4091249—1949 to 52, B.S. 1008-120847
4074627—1949 to 52, B.S. 1069-1269-1061-106240
4091252—1953, sdn.47
4073936—1953, sta. wag.40
9 WINDOW LOWER SASH CHANNEL CAM	
4099974—1949 to 53, B.S. 1008-69-1208-6940
10 DOOR GLASS	
4559296—1949 to 52, B.S. 1069-1269	10.75
4560991—1949 to 52, B.S. 1008-1208	11.72
4566723—1949 to 52, B.S. 1062	16.26
4566724—1949, B.S. 1061	15.72
4560086—1949 to 52, B.S. 1269, stationary section	3.80
4570656—1949 to 52, B.S. 1208, stationary section	2.86
4600533—1953, sdn.	12.95
4603271—1953, sta. wag.	15.58
11 DOOR VENTILATOR	
4561624—1941 to 52, B.S. 1008 (right*)	11.95
4559578—1949 to 52, B.S. 1069 (right*)	11.95
12 WINDOW GLASS CHANNEL	
4045914—1949 to 52, B.S. 1008-61-69-1208-69	1.85
4074354—1949 to 52, B.S. 1061-1062	1.30
4075477—1949 to 53, B.S. 1062, upper w/chrome bead	2.20
4606055—1953, sdn. low.70
4606058—1953, sta. wag. low... ..	.70
13 DOOR GLASS DIVISION CHANNEL	
4568934—1949, B.S. 1269, 1st type (right*)	3.55

4151740—1949 to 52, B.S. 1069 (right*)	3.87
4604078—1949 to 52, 1008 (right*)	3.55
4577624—1949, B.S. 1208, 1st type (right*)	2.98
4577620—1949, B.S. 1269, 2nd type (right*)	3.55
4577624—1949, B.S. 1208, 2nd type (right*)	2.98
4580637—1950, B.S. 1208 (right*)	2.98
4580639—1950, B.S. 1269 (right*)	3.55
14 VENTILATOR GLASS	
4559589—1949 to 52, B.S. 1069	3.83
4560940—1949 to 52, B.S. 1008	2.97
4560086—1949 to 52, B.S. 1269, stationary section	3.80
4570656—1949 to 52, B.S. 1208, stationary section	2.86
15 VENTILATOR HANDLE	
4167988—1949 to 52, B.S. 1008-61-62-69 (left*)90
16 VENTILATOR WEATHERSTRIP	
4168187—1949, B.S. 1069 (right*)	1.42
4168189—1949, B.S. 1008 (right*)	1.42
4175692—1950 to 52, B.S. 1008 (right*)	1.70
4175694—1950 to 52, B.S. 1069 (right*)	1.70
17 VENTILATOR GLASS CHANNEL	
4167997—1949 to 52, B.S. 1008 (right*)	4.92
4167999—1949 to 52, B.S. 1069 (right*)	4.92
4577610—1949, B.S. 1269, 1st type (right*)	2.38
4577610—1949 to 52, B.S. 1269, 2nd type (right*)	2.38
4577611—1949, B.S. 1269, 2nd type (left)	2.38
4570882—1949, B.S. 1208, 1st (right*)	2.55
4577614—1949 to 52, B.S. 1208, 2nd type (right*)	2.55
18 CHECK LINK	
4586827—1949 to 52, B.S. 1008-62-69-1208-6940
4566686—1949, B.S. 106147
4600310—195352
19 DOOR LOCK STRIKER	
4604441—1949, 50	1.22
4604440—1952 (right*)	1.22
4604438—1953	1.23
20 WINDOW REGULATOR HANDLE	
4564255—1949, ser. 1000, exc. sta. wag.	1.62
4564255—1949, ser. 1200	1.62

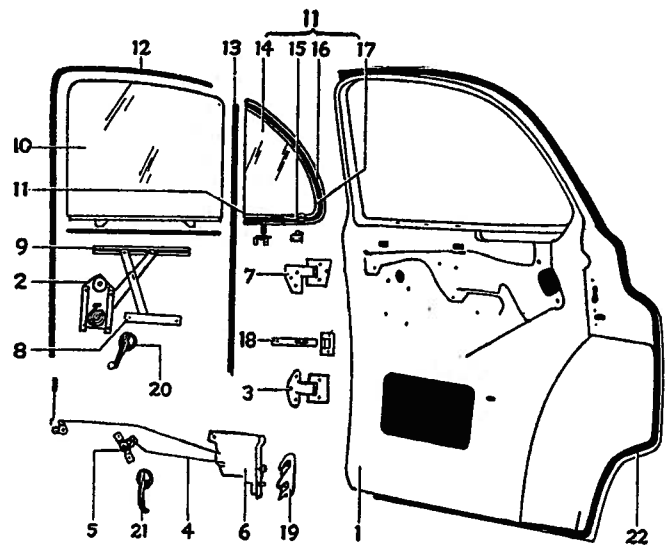

Fig. 16—Rear Door (Left Side Part Numbers Shown)
4-Door Sedans and Station Wagons

* Opposite side one part number higher

continued

CHEVROLET 1949 thru 1953 BODY PARTS

ALL BODY STYLES

Rear Door—continued

4564479—1949, sta. wag.	1.50
4582152—1950, ser. 1000, closed	1.62
4582151—1950, ser. 1200	1.50
4582154—1950, sta. wag.	1.50
4601168—1951-52, ser. 1000, closed	1.62
4594189—1951-52, ser. 1200...	1.50
4601171—1951-52, sta. wag....	1.50
4619387—1953	1.50
21 LOCK INSIDE HANDLE	
4564254—1949 to 52, closed...	1.02
4572980—1949 to 52, sta. wag.	.98
3703632—1953	1.02
22 DOOR OPENING WEATHER- STRIP	
4565914—1949 to 52, lock pillar, lower (right*)78
4565924—1949 to 52, B.S. 1062, rear hinge pillar (right*)..	1.98
4565922—1949 to 52, B.S. 1008- 1208, rear hinge pillar (right*)	1.98
4565920—1949 to 52, B.S. 1069- 1269, rear hinge pillar (right*)	1.98
4566963—1949, B.S. 1061, rear hinge pillar (right*)	1.98
4191860—1953	2.85

Rear of Car

See Fig. 17

1 BUMPER CENTER FACE BAR	
3698600—1949 to 52	5.02
3697690—1953, sta. wag.	9.50
3697689—1953	4.95
2 OUTER FACE BAR	
3698601—1949 to 52 (left*)....	5.57
3697343—1953 (left*)	5.57
3 BUMPER GUARD	
3698611—1949 (right rear*)..	2.89
3698611—1950-51, SDL, sta. wag. (right rear*)	2.89
3692645—1950, exc. SDL, sta. wag. (left rear*)	3.29
3698609—1951 to 52, exc. SDL, sta. wag. (left rear*)	3.29
3697477—1953 (left*)	3.05
3698225—1953, sta. wag. (left*)	3.05
4 FENDER GUARD	
3695801—1951-52 (left rear*)..	8.25
3702943—1953 (left*)	10.85
5 FRAME TO BUMPER ATTACH- ING OUTER BAR, REAR	
3688293—1949-50, exc. sta. wag. (left*)	1.11
3695021—1951-52, exc. sta. wag. (left*)	1.11

3697911—1953 (left*)	1
3697993—1953, sta. wag. (left*)	1
6 FRAME TO BUMPER ATTACH- ING INNER BAR	
3688291—1949-50, exc. sta. wag. (left*)	1
3695019—1951-52, exc. SDL, sta. wag. (left*)	1
3697987—1953 (left*)	1
3697991—1953, sta. wag. (left*)	1
7 REAR BUMPER DEFLECTOR	
3689015—1949 to 51, sta. wag..	2
3688583—1949-50, exc. sta. wag.	3
3695903—1951-52, exc. SDL, sta. wag.	3
3702008—1953	2
3702010—1953, sta. wag.	4
8 REAR LICENSE LAMP	
927656—1949-50, exc. SDL, sta. wag.	2
927655—1951-52, exc. SDL, sta. wag.	2
928796—1953	3
928358—1953, sta. wag.	2
9 REAR LICENSE ATTACHING BRACKET	
5938846—1941 to 51, sta. wag.	
5938180—1949 to 52, exc. SDL, sta. wag.	
5942458—1953, pass.	
10 TAIL AND STOP LAMP	
927887—1949 to 51, sta. wag. (left*)	5
926017—1949 to 51, center, sta. wag.	7
927577—1949, all pass. exc. SDL, sta. wag. (left*)	5
927755—1950, all pass. exc. SDL, sta. wag. (left*)	5
927883—1951-52, exc. SDL, sta. wag. (left*)	5
928266—1953	8
10 TAIL AND STOP LAMP RIM	
5937863—1949-50, exc. SDL, sta. wag. (left*)	1
5941091—1951-52, exc. SDL, sta. wag.	2
5943401—1953	2
10 TAIL LAMP LENS	
5937861—1949, exc. SDL, sta. wag.	
5939421—1950, exc. SDL, sta. wag.	
5940038—1951-52, exc. SDL, sta. wag.	
5943403—1953, out. up.	
5944070—1953, in. up.	
5943406—1953, center	
5943404—1953, low.	
11 FENDER CROWN MOLDING	
4561542—1949-50, exc. 4 dr. (right*)	2
4561544—1949-50, 4 dr. and sta. wag. (right*)	2
4561544—1951, sta. wag. (right*)	2
3695257—1951, ser. 1000, exc. sta. wag.	2
986702—1952, exc. SDL	2

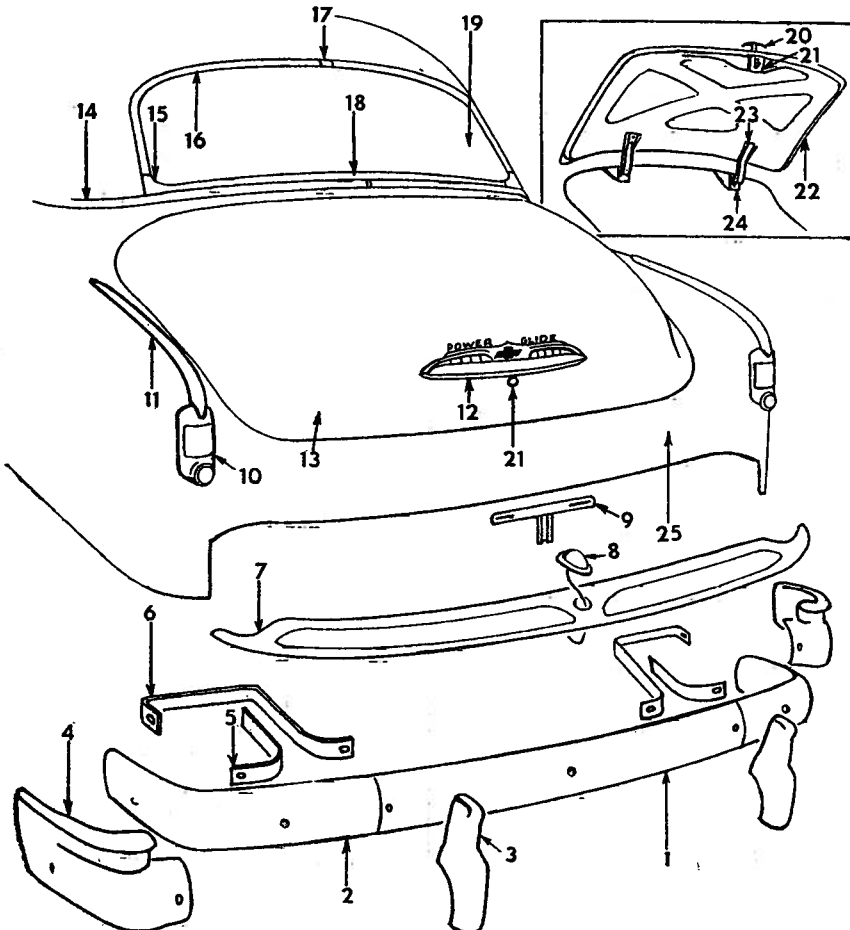

Fig. 17—Rear of car sheet metal

* Opposite side one part number higher

BODY PARTS 1949 thru 1953 CHEVROLET

ALL BODY STYLES

REAR COMPARTMENT LID LOCK HANDLE	
4167893—1949, exc. sta. wag...	2.93
4171922—1947 to 51, sta. wag., upper end gate outside	3.88
4578807—1950, exc. Fleetline..	3.70
4579256—1950, Fleetline	3.70
4171922—1953, sta. wag.	3.88
3702732—1953, w/P.G.	4.85
3702729—1953, exc. P.G.	4.85

REAR COMPARTMENT LID EMBLEM	
3688052—1949, exc. sta. wag...	1.57
3699038—1949 to 51, sta. wag..	1.57
3694841—1950, Ser. 1000 w/P.G. "Power"	1.42
3694842—1950, Ser. 1000 w/P.G. "Glide"	1.42
3699037—1951, B.S. 1007-8 w/P.G. "Power Glide"	3.70
3699036—1951, B.S. 1011-27-37-67-69 w/P.G. "Power Glide"	3.70
3695335—1951, Styleline, exc. P.G.	3.28
3695664—1951, Fleetline, exc. P.G.	3.28
3693353—1950, exc. P.G. molding (left*)	.80
3699723—1952, B.S. 1007 w/P.G. "Power Glide"	4.48
3699721—1952, Styleline w/P.G. "Power Glide"	4.48
3699708—1952, B.S. 1007, exc. P.G.	3.88
3699617—1952, Styleline, exc. P.G.	3.88
3697660—1953, sta. wag. 1953 pass. see lid handle above.	1.42

REAR COMPARTMENT LID	
4180870—1949 to 51, B.S. 1011-69-1211-69	38.80
4180873—1949 to 52, Fleetline.	38.80
4180876—1949 to 52, cpes., CBL, B-A	43.14
4591175—1953, 2 & 4D	40.50
4592888—1953, cpes.	44.75

REAR QUARTER BELT MOLDING	
4561872—1949 to 51, B.S. 1069-1269 (right*)	2.18
4561955—1949 to 51, cpes. (right*)	3.55
4562043—1949 to 51, B.S. 1011-1211 (right*)	3.83
4563260—1949 to 51, B.S. 1007-1207 (right*)	2.73
4562911—1949 to 51, B.S. 1008-1208 (right*)	2.02
4579792—1949 to 51, CBL, Bel Air (right)	3.17
4579793—1949 to 51, CBL, Bel Air (left)	3.17
4614937—1952, B.S. 1007-11-27-37-67	3.28
4610265—1952, B.S. 1069	3.07
4596789—1953, cpes. (right*)	3.67
4597197—1953, 2D (right*)	3.95
4597201—1953, 4D (right*)	2.48
4600536—1953, sta. wag. (right*)	2.75

15 BACK WINDOW GLASS REVEAL MOLDING (Lower Corner)	
4561617—1949 to 52, B.S. 1027 (right*)	1.10
4561721—1949 to 52, B.S. 1011-69 (right*)	1.10
4596047—1953, 1211 & cpes.	22.25
4616100—1953, 1011, 69	29.75
4618686—1953, 1037	32.50

16 BACK WINDOW GLASS REVEAL MOLDING (Upper)	
4561487—1949 to 52, B.S. 1011-69 (right*)	2.73
4561466—1949 to 52, B.S. 1027 (right*)	2.73
4562137—1949 to 52, B.S. 1007-08 (right)	3.55
4578936—1950 to 52, Belair (right*)	2.47
4595318—1953, 1027, up.	3.20
4595990—1953, 1011, 69, up.	3.62
4595925—1953, 1037, up.	3.75

17 BACK WINDOW GLASS REVEAL MOLDING ESCUTCHEON	
4562218—1949 to 52, B.S. 1007-08-11-27-69-71	.22
4586841—1950 to 52, Bel Air, lower	.27
4580629—1950 to 52, Bel Air, clip, side	.03
4571696—1950 to 52, Bel Air, clip, lower rear	.03
4571697—1950 to 52, Bel Air, clip, upper rear	.03
4597174—1953, 1011W, 69W, 37, low.	.22
4595379—1953, 1027	.25

BACK WINDOW DIVISION MOLDING	
4578502—1950 to 52, Bel Air, outer	.95
4591242—1950 to 52, Bel Air, inner (right*)	2.08

18 BACK WINDOW GLASS LOWER REVEAL MOLDING	
4561502—1949 to 52, B.S. 1011-69	2.13
4561494—1949 to 52, B.S. 1027	2.13
4579092—1950 to 52, Bel Air, lower front (right*)	1.03
4586977—1950 to 52, Bel Air, lower rear (right*)	2.85
4595093—1953, 1027, low.	2.50
4595992—1953, 1011W, 69W, low. (right*)	2.80
4614263—1953, 1011WD, 69WD, low.	3.55
4601533—1953, 1037, low. (right*)	2.88

19 BACK WINDOW GLASS	
4559990—1949 to 52, B.S. 1007-08-1207-08	16.98
4561843—1949 to 52, B.S. 1027-1227-27B	15.06
4559993—1949 to 52, B.S. 1011-69-1211-69	16.98

4577106—1950 to 52, Bel Air, (right side*)	7.51
4577108—1950 to 52, Bel Air, center	13.15
4597407—1951-52, CBL plastic	10.18
4566730—1949, B.S. 1061, upper end gate	15.15
4566729—1949 to 52, B.S. 1062, upper end gate	15.63
4596047—1953, 1027, 1211, 27, 69	22.25
4616100—1953, 1011, 69	29.75
4618686—1953, 1037	32.50

20 REAR COMPARTMENT LID LOCK HANDLE	
4167893—1949, all exc. sta. wag.	2.93
4171922—1947 to 51, sta. wag., upper end gate	3.88
4578807—1950, all	3.70
4579256—1950, Fleetline	3.70
4171922—1953, sta. wag.	3.88
3702732—1953, w/P.G.	4.85
3702729—1953, exc. P.G.	4.85

REAR COMPARTMENT LID HANDLE	
3699723—1951-52, B.S. 1007, w/P.G.	4.48
3699721—1951-52, Styleline, w/P.G.	4.48

21 REAR COMPARTMENT LID LOCK	
4560685—1949	2.68
4579015—1950	2.95
4576315—1951-52	3.98
4572916—1953	3.92

22 REAR COMPARTMENT LID WEATHERSTRIP	
4573804—1949 to 52, B.S. 1007-08-1207-08 (gutter)	3.33
4605095—1949 to 52, cpes., CBL, Belair (gutter)	3.22
4576143—1949 to 52, B.S. 1011-69-1211-69 (gutter)	3.27
4590474—1949-50, B.S. 1011-69-1211-69 (1st type) on lid	2.55
4590474—1949-50, cpe., CBL (1st type) on lid	2.55
4590474—1950 to 52, Styleline (2nd type) on lid	2.55
4590474—1949 to 52, Fleetline, on lid	2.55
4590474—1950 to 52, cpe., DBL, B-A (2nd type) on lid	2.55
3692045—1949 to 52, B.S. 1061-1062, lower side ft.	.13
4566970—1949, B.S. 1061, upper end gate top	1.98
4566486—1949 to 52, B.S. 1062, upper end gate top	1.98
4566969—1949, B.S. 1061, upper end gate	1.42
4566485—1949 to 52, B.S. 1062, upper end gate	1.42
4572565—1949 to 52, B.S. 1061-62, lower end gate	1.98
4172355—1949 to 52, B.S. 1061-62, opening. on body	1.13
4601338—1953, 2 & 4D	4.00
4603360—1953, cpes.	4.00
4615298—1953, silver ink	2.68

continued

* Opposite side one part number higher

CHEVROLET 1949 thru 1953 BODY PARTS

ALL BODY STYLES

Rear of Car—continued

23 REAR COMPARTMENT LID HINGE STRAP	
4167932—1949-50, B.S. 1011-69-1211-69 (1st type)	3.23
4167936—1949 to 52, B.S. 1007-08-1207-08	3.23
4167939—1949 to 52, cpes.	3.23
4167942—1949 to 52, CBL	2.00
4174637—1950 to 52, Bel Air..	3.69
4173475—1950 to 52, B.S. 1011-69-1211-69 (2nd type)	3.23
4150122—1949 to 52, CBL, link and spring	3.23
4150528—1953, cpes.	5.25
4191694—1953, conv.	2.00
24 REAR COMPARTMENT LID HINGE BOX	
4167940—1949 to 52, CBL (right*)	2.68
4167937—1949 to 52, cpes. (right*)	1.77
4167929—1949-50, B.S. 1011-69-1211-69 (1st type) (right*)	1.77
4167934—1949 to 52, B.S. 1007-08-1207-8 (right*)	2.00
4174635—1950 to 52, Bel Air (right*)	1.71
4173473—1950 to 52, B.S. 1011-69-1211-69 (2nd type) (right*)	1.77
4573440—1949 to 53, B.S. 1062, upper end gate hinge (right*)	4.14
4562961—1949 to 52, sta. wag., lower end gate hinge	11.09
4573441—1949 to 53, sta. wag., unner end gate hinge (left) ..	4.14
4191686—1953, 2 & 4D (right*) ..	2.00
4150534—1953, cpes. (right*) ..	1.77
4191692—1953, conv. (right*) ..	2.68
4150536—1953, 1037 (right*) ..	2.00
25 BODY BACK LOWER PANEL	
4584482—1949-50, Fleetline ...	10.11
4584477—1949-50, B.S. 1011-69-1211-69	9.32
4584491—1949-50, cpes., CBL, B-A	9.32
4584486—1949 to 52, B.S. 1062 ..	7.06
4588359—1951-52, Fleetline ...	6.78
4588360—1951-52, Styleline, exc. SDL, sta. wag.	2.32
4596662—1953, exc. sta. wag. ..	5.90
4602363—1953, sta. wag.	6.50

Frame

All Models

1 FRAME ASSY.	
3697645—1949 to 51, exc. CBL, B-A, P.G.	81.62
3697643—1949 to 51, CBL	150.72
3697641—1950 to 51, w/P.G., exc. CBL, B-A	81.62
3697639—1950 to 51, Bel Air, exc. P.G.	108.82
3697647—1950 to 52, Bel Air, w/P.G.	108.82

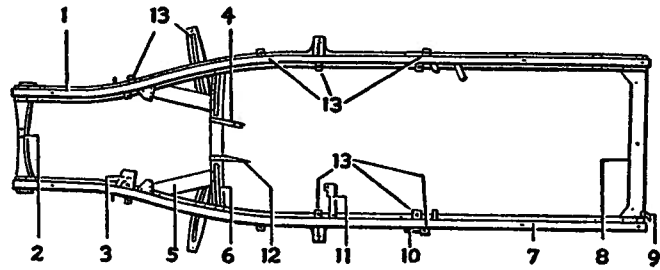

Frame

3701191—1952, pass., exc. CBL, B-A	87.14
3701193—1952, CBL	150.73
3701195—1952, Bel Air	116.17
3703549—1953, pass.	87.14
3703691—1953, CBL	150.73
3703615—1953, spt. cpe.	116.17
2 FRONT CROSS MEMBER	
3688035—1949 to 53	1.91
3 PARKING BRAKE BRACKET	
3689491—1949 to 52	1.35
3698391—1953	1.35
4 PARKING BRAKE IDLER LEVER BRACKET	
3690347—1949 to 52, exc. CBL, P.G.45
3688195—1949 to 53, CBL.23
3689994—1950 to 53, w/P.G., exc. CBL27
5 CROSS MEMBER BRACE	
3690355—1949 to 51, exc. CBL, P.G. (left)	3.12
3690522—1949 to 51, exc. CBL, P.G. (right)	3.12
3690405—1950-51, w/P.G., exc. CBL (left*)	3.12
3697805—1952-53, exc. CBL ..	3.12
6 SECOND CROSS MEMBER	
3690339—1949 to 51, exc. CBL, P.G.	4.03
3690411—1950-51, w/P.G., exc. CBL	4.03
3700261—1952-53, exc. CBL ...	4.03
7 FRAME SIDE MEMBER	
3701117—1949 to 51, exc. CBL (left*)	35.37
3701117—1952, exc. CBL (left*)	35.37
3703697—1953	36.21
8 REAR CROSS MEMBER	
3696896—1949-52	4.03
3697757—1953	4.03
9 TAIL PIPE SUPPORT BRACKET	
3690052—1949-50, exc. P.G....	.56
3690052—1950, CBL, w/P.G.56
3690051—1949-50 ("L" shape)	.16
3693035—1950, w/P.G., exc. CBL support56
3696881—1951-52, exc. P.G.	1.31
3696881—1951-52, CBL, w/P.G. support, w/insulator	1.31
3696885—1951-52, w/P.G., exc. CBL support, w/insulator ..	1.31
3697973—1953	1.31

10 REAR SPRING FRONT HANGER	
3697792—1941 to 52	1
11 MUFFLER BRACKET	
3661832—1941 to 50, exc. P.G..	
3661832—1950, CBL, w/P.G. ..	
3693055—1950, w/P.G., exc. CBL	
12 PARKING BRAKE IDLER LEVER GUIDE	
3690345—1949 to 51, exc. CBL, P.G.	
3688197—1949 to 53, CBL	
3689995—1950 to 53, w/P.G., exc. CBL	
13 BODY BRACKET	
3687904—1949 to 53, No. 1 inner R.H.	
3687904—1949 to 53, No. 1 outer	
3688045—1949 to 52, exc. CBL, No. 2 body L.H.	2
3689016—1949 to 52, exc. CBL, No. 2 R.H.	2
3692433—1949 to 52, CBL, No. 2	2
3665440—1949 to 53, exc. CBL, No. 3	
3665440—1949 to 53, CBL, No. 3 outer	
3665438—1941 to 53, No. 4 outer	
3665440—1949 to 53, No. 4 inner	
3687903—1949 to 53, exc. CBL, B-A, No. 5 L.H.	
3665440—1949 to 53, exc. CBL, No. 5 R.H.	
3687903—1949, CBL, No. 6 outer L.H.	
3687903—1951-53, CBL, Bel Air, No. 6 inner and outer L.H..	
3665440—1949 to 53, CBL, Bel Air, No. 6 outer R.H.	
3665440—1950 to 53, Bel Air, No. 6 inner R.H.	

Front Suspension

All Models

1 STEERING KNUCKLE SUPPORT ARM	
3692170—1949 to 52 (upper arm)	1
3693469—1953 (left*)	5

* Opposite side one part number higher

BODY PARTS 1949 thru 1953 CHEVROLET

ALL BODY STYLES

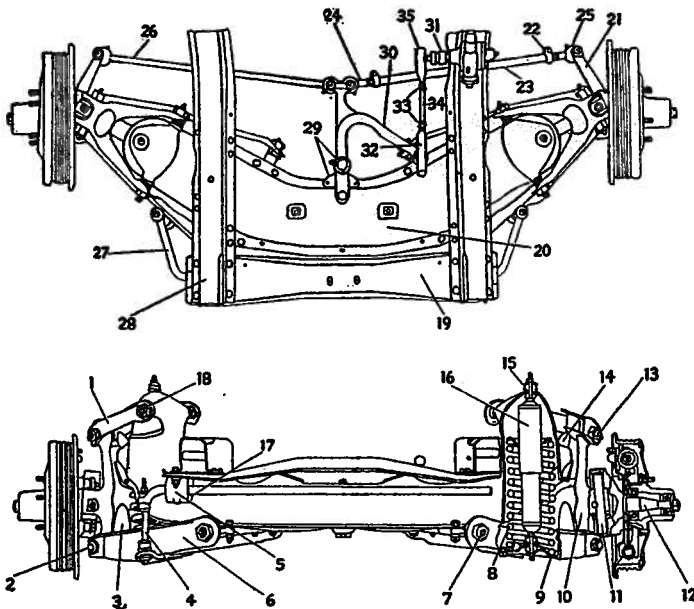

LOWER PIVOT ARM BOLT UNIT 3690683—1949 to 53	1.31
SUPPORT ARM LOWER BUMPER 3687669—1949 to 5342
STABILIZER LINK 599432—1939 to 53, bolt type..	.27
STABILIZER SHAFT BRACKET 3653101—1940 to 53, exc. KB.	.32
STEERING KNUCKLE SUPPORT LOWER ARM 3693469—1949 to 53 (left*) ...	5.52
LOWER SUPPORT ARM INNER SHAFT 3690685—1949	4.05
3693459—1949 to 53	3.78
KNEE ACTION SPRING 3694210—1950 to 52, w/P.G., black strip	5.18
3694210—1950 to 52, CBL ...	5.18
3694612—1949, all pass, yellow strip	5.18
3694612—1950 to 52, exc. P.G., CBL	5.18
3703787—1953, w/P.G.	5.18
3703788—1953, w/o P.G.	5.18
SHOCK ABSORBER AXLE BRACKET 3688548—1949 to 5348
STEERING KNUCKLE SUPPORT 3687651—1949 to 52 (left*) ..	6.45
3703785—1953 (left*)	6.45
KING PIN REPLACEMENT UNITS 603386—1939 to 53	4.45
KING PIN 599207—1939 to 5396
STEERING KNUCKLE 3696323—1949-50	9.75
3696323—1951 to 53	9.75

13 UPPER ARM OUTER BOLT UNIT 3690684—1949 to 53	1.47
14 KNUCKLE SUPPORT ARM UPPER BUMPER 3687670—1949 to 5332
15 SHOCK ABSORBER LINK BUSHING 5304209—1949 to 5310
16 SHOCK ABSORBER ASSY. 5394583—1949 to 52	5.10
5519443—1953	5.75
17 FRONT STABILIZER SHAFT BUSHING 599430—1939 to 53, exc. JB, KB28
18 UPPER CONTROL ARM INNER SHAFT UNIT 3693693—1949 to 53	1.87
19 FRAME FRONT CROSS MEMBER 3688035—1949 to 53	1.91
20 FRONT SUSPENSION MEMBER 3691555—1949 to 53	26.50
21 STEERING KNUCKLE ARM 3691175—1949 to 53 (left*) ...	2.27
22 TIE ROD END CLAMP 599234—1939 to 53, exc. JB18
23 FRONT AXLE SHORT TIE ROD 3691181—1949 to 53	1.04
24 TIE ROD END 3692951—1939 to 53, exc. JB (left)	1.95
25 TIE ROD END 3692952—1939 to 53, exc. JB (right)	1.95

26 FRONT AXLE LONG TIE ROD 3692953—1949 to 53	4.95
27 STABILIZER SHAFT 3688966—1949 to 53	2.15
28 FRAME SIDE MEMBER 3701117—1949 to 51, exc. CBL (left*)	35.37
3701117—1952, exc. CBL (left*)	35.37
3703697—1953 (left*)	36.21
29 STEERING IDLER AND THIRD ARM BRACKET 3691167—1949 to 53, with bushing	4.60
30 STEERING IDLER AND THIRD ARM ASSY. 3691171—1949 to 53	7.30
31 PITMAN ARM 3691183—1949 to 53	3.85
32 STEERING CONNECTING ROD END UNIT 3690842—1949 to 53 (L.H. Thr.) at 3rd arm	1.93
33 CONNECTING ROD SLEEVE CLAMP 599234—1949 to 5318
34 CONNECTING ROD ADJUSTING SLEEVE 3687942—1949 to 5364
35 CONNECTING ROD END UNIT 3690844—1949 to 52 (R.H. Thr.) 3690844—1949 to 53 (R.H. Thr.)	

STEERING GEOMETRY

1949 to 1953

CASTER: 1949-51 0 to 1/2 degree positive.
1952-53 0 to 1 degree positive.

CAMBER: 1949-51 1/2 degree negative to
1/2 degree positive. 1952-53 0 to 1 de-
gree positive.

TOE-IN: 0 to 1/8 inch

TOE-OUT TURNS (TURNING RADIUS)
Outer Wheel 20 degrees. Inner Wheel
24 degrees. 1953 inner wheel 17 3/4
degrees.

KING PIN INCLINATION: 1949-51 4 de-
grees. 1952-53 3 1/2 to 4 1/2 degrees.

ADJUSTMENTS

CASTER: Is controlled by full turns of the
upper eccentric pin.

CAMBER: Is controlled by eccentric upper
pin and full range is obtained in one-half
turn.

TOE-IN: Should be adjusted at tie rod.
Turn rod in direction of forward wheel
rotation to decrease toe-in.

* Opposite side one part number higher

FRAMES 1949 thru 1953 CHEVROLET

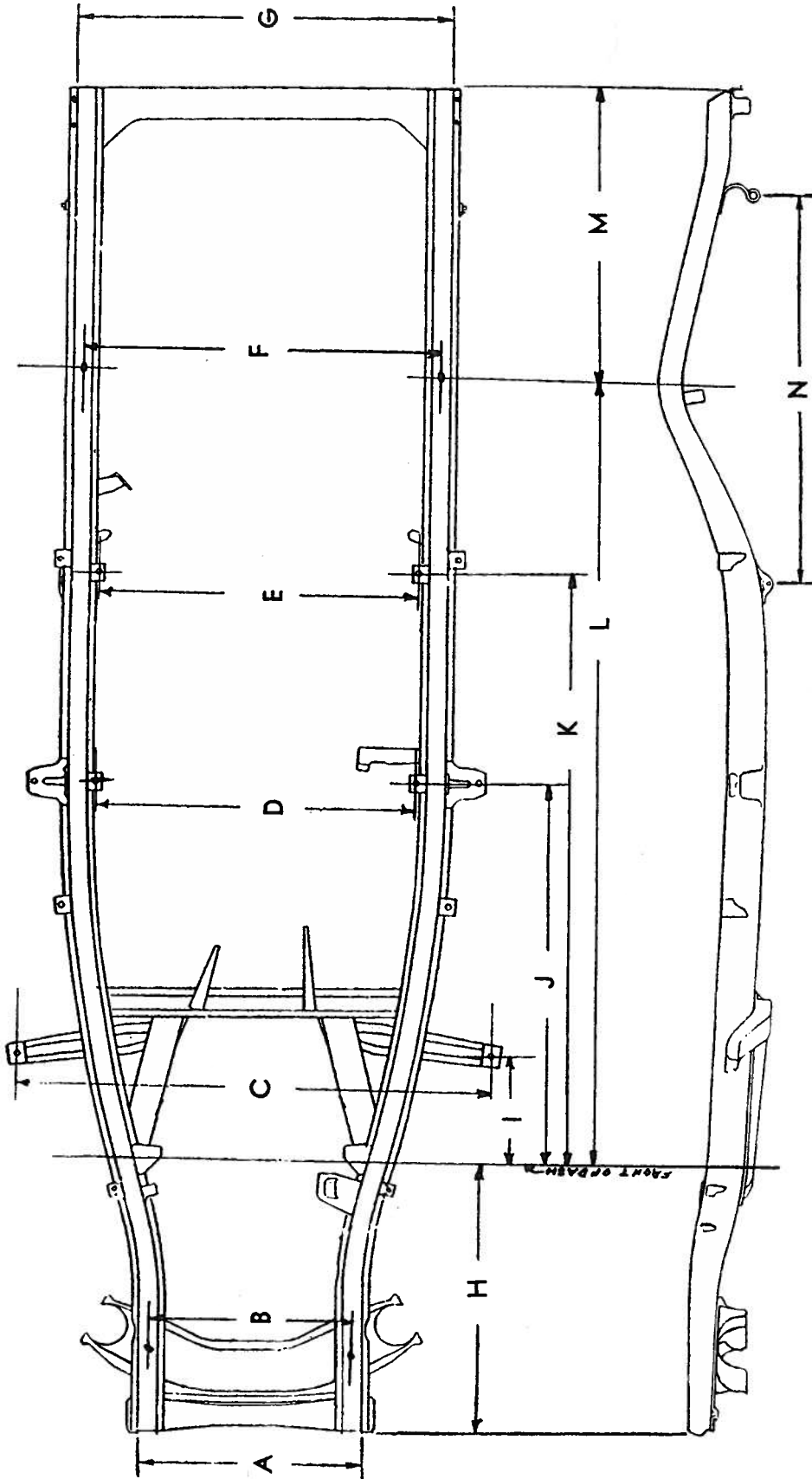

Dimension Point

Model and Series	A	B	C	D	E	F	G	H	I	J	K	L	M	N
1949-1951 (except Convertible)	261 ³ / ₃₂	24 ³ / ₁₆	57 ¹ / ₂	38 ¹ / ₂	38 ¹ / ₂	43 ¹ / ₈	45 ³ / ₈	35	12 ¹ / ₂	461 ³ / ₁₆	73 ³ / ₈	100	341 ³ / ₁₆	491 ¹ / ₄
1952-1953 (except Convertible)	261 ³ / ₃₂	24 ⁵ / ₃₂	57 ¹ / ₂	38 ¹ / ₂	38 ¹ / ₂	43 ¹ / ₈	45 ³ / ₈	12 ⁵ / ₃₂	461 ³ / ₁₆	73 ¹ / ₂	99 ³ / ₃₂	491 ³ / ₆₄