

# KAISER-FRAZER

## Frame Dimensions—1951-1953

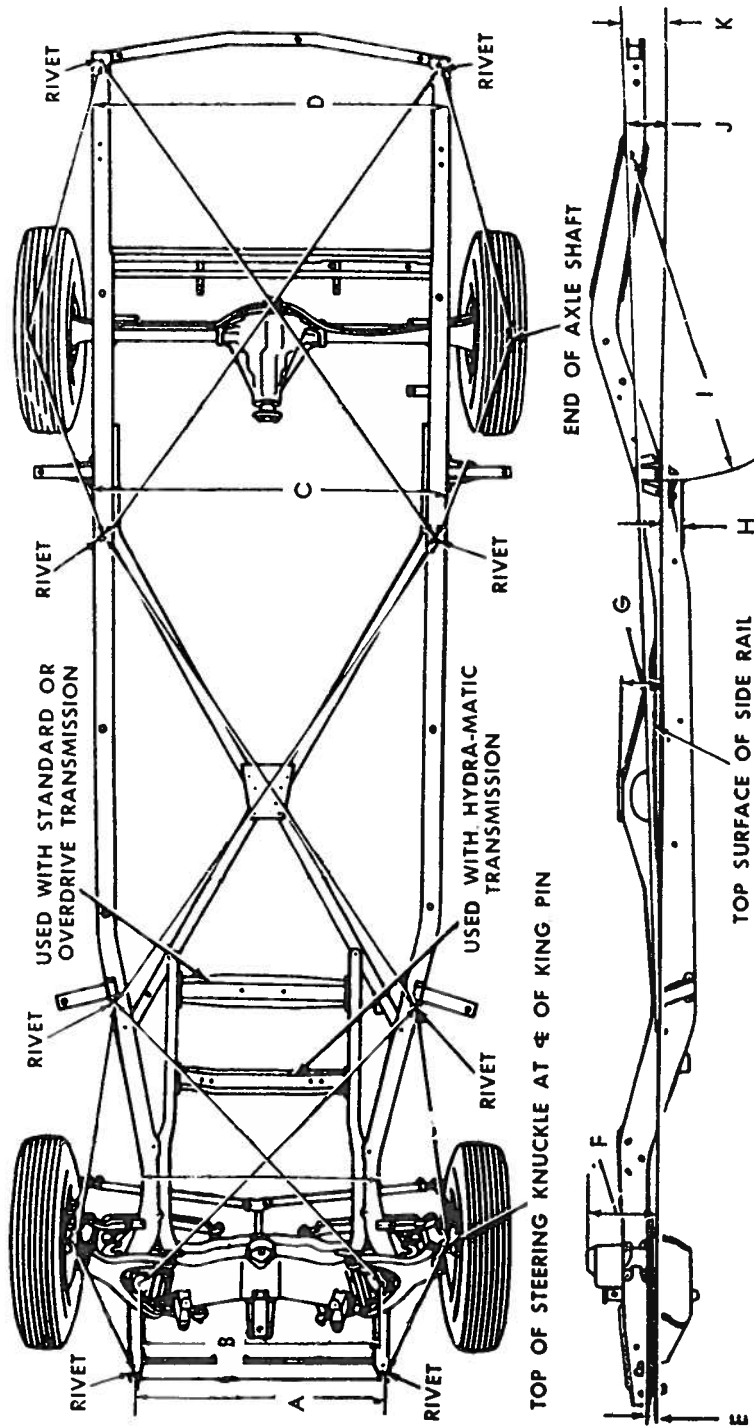

Model and Series	Dimension Point										
	A	B	C	D	E	F	G	H	I	J	K
1951-1953—All Models.....	34 <sup>5</sup> / <sub>8</sub>	31 <sup>3</sup> / <sub>4</sub>	47	47	2 <sup>9</sup> / <sub>32</sub>	10 <sup>17</sup> / <sub>64</sub>	3 <sup>15</sup> / <sub>32</sub>	12 <sup>7</sup> / <sub>64</sub>	50 <sup>1</sup> / <sub>8</sub>	4 <sup>15</sup> / <sub>16</sub>	4 <sup>7</sup> / <sub>8</sub>

**BODY PARTS 1951 thru 1953 KAISER**

**Models K511, K512, K521, K522, 530, 531 and 532. ALL BODY STYLES**

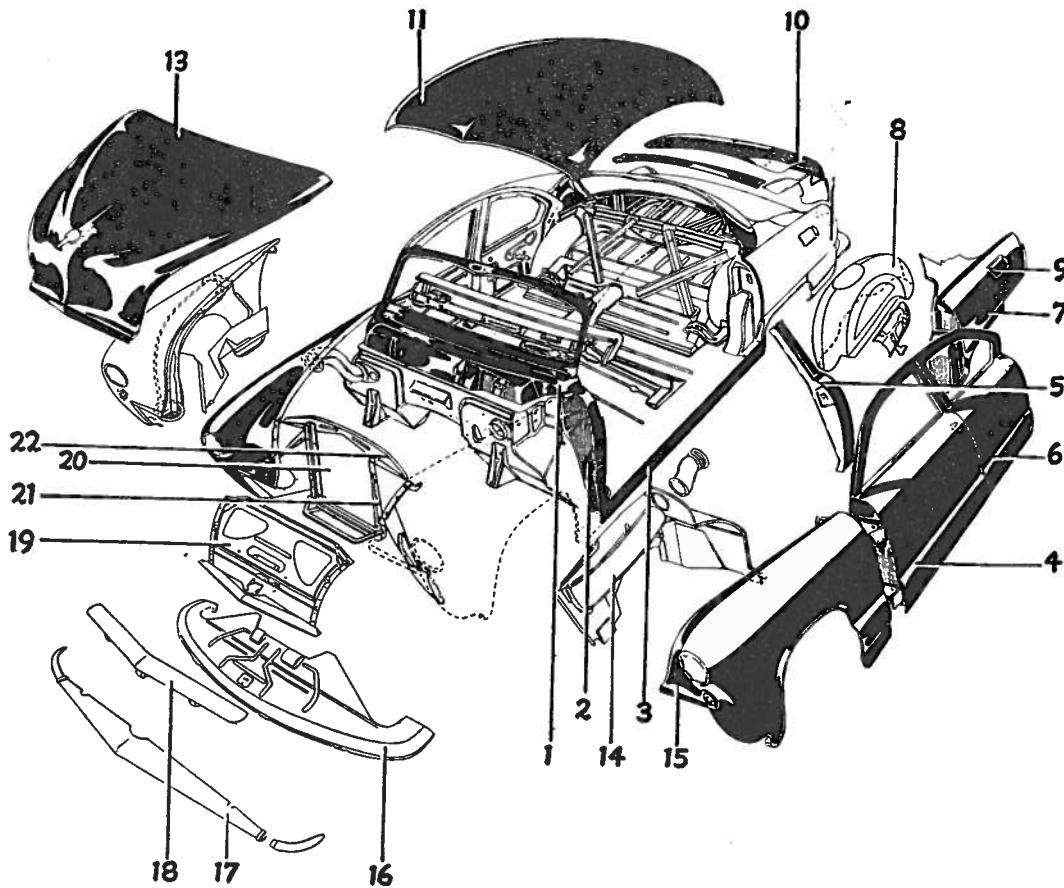

Fig. 1

**Body Sheet Metal**

*Typical of All Body Styles*

See Fig. 1

<b>1 COWL COMPLETE</b>	
213911—1951 .....	80.50
213211—1952-53 .....	80.50
<b>2 FRONT PILLAR</b>	
207658—1951 to 53 (right*)..	15.25
<b>3 ROCKER PANEL</b>	
207740—1951 to 53, 4 dr. sed. and 4 dr. util. (right*) ....	4.56
207742—1951 to 53, bus. cpe., 2 dr. sed., club cpe., 2 dr. util. (right*) .....	3.50
<b>4 FRONT DOOR</b>	
207811—1951 to 53, 4 dr. sed. and 4 dr. util. (right*) ....	50.20
207813—1951 to 53, bus. cpe., 2 dr. sed., club cpe., 2 dr. util. (right*) .....	55.27
<b>5 CENTER PILLAR</b>	
207662—1951 to 53 (right*) ..	9.85
<b>6 REAR DOOR</b>	
207870—1951 to 53 (right*) ..	50.20

<b>7 REAR QUARTER PANEL</b>	
214086—1951-52, 4 dr. sed. (right*) .....	21.50
214088—1951-52, 2 dr. sed. (right*) .....	27.40
208526—1951-52, 4 dr. util. (right*) .....	21.50
207668—1951-52, bus. cpe. and club cpe. (right*) .....	27.40
207670—1951-52, 2 dr. util. (right*) .....	27.40
214086—1953, 4 dr. (right*) ..	21.50
214088—1953, 2 dr. (right*) ..	27.40
<b>QUARTER PANEL LOWER FRONT EXTENSION</b>	
207672—1951 to 53, bus. cpe., 2 dr. sed., club cpe., 2 dr. util. (right*) .....	1.27
<b>QUARTER PANEL LOWER REAR EXTENSION</b>	
207674—1951 (right*) .....	1.77
213180—1952-53 (right*) ....	1.57

<b>8 REAR WHEEL HOUSING OUTER PANEL</b>	
207676—1951 to 53 (right*) ..	6.59
<b>REAR WHEEL HOUSING INNER PANEL</b>	
207678—1951 to 53 (right*) ..	6.08
<b>9 FUEL TANK FILLER COVER</b>	
207313—1951 to 53 .....	1.27
<b>10 DECK LID</b>	
207889—1951, all exc. util....	37.01
213215—1952, all exc. util....	37.00
207890—1951-52, upper lid, util.	40.26
207891—1951-52, lower lid, util.	38.03
213215—1953, 521, 22 exc. util.	37.00
213930—1953, 530, 1, 2, 4 & 2 dr. ....	36.50
<b>11 ROOF PANEL</b>	
207713—1951 to 53, 4 dr. sed.	57.50
207714—1951 to 53, 2 dr. sed.	53.24
207715—1951 to 53, 4 dr. util.	58.25

*continued*

\* Opposite side one part number higher

# KAISER 1951 thru 1953 BODY PARTS

Models K511, K512, K521, K522, 530, 531 and 532. ALL BODY STYLES

## Body Sheet Metal— continued

207716—1951 to 53, bus. cpe. and club cpe. ....	53.24
207717—1951 to 53, 2 dr. util. ....	58.25

### 12 BODY SHELL, INCL. DOORS AND DECK LID

207691—1951, 511, 4 dr. sed... ..	....
213185—1952 to 53, 521, 4 dr. sed. ....	....
207692—1951, 512, 4 dr. sed... ..	....
213186—1952 to 53, 522, 4 dr. sed. ....	....
207694—1951, 511, bus. cpe... ..	....
213188—1952, 521, bus. cpe... ..	....
213189—1952, 522, bus. cpe... ..	....
207695—1951, 511, 2 dr. sed... ..	....
207696—1951, 512, 2 dr. sed... ..	....
213190—1952 to 53, 521, 2 dr. sed. ....	....
213191—1952 to 53, 522, 2 dr. sed. ....	....
207697—1951, 511, 4 dr. util... ..	....
207698—1951, 512, 4 dr. util... ..	....
213192—1952, 521, 4 dr. util... ..	....
213193—1952 to 53, 522, 4 dr. util. ....	....
207699—1951, 512, club cpe... ..	....
213194—1952, 521, club cpe... ..	....
213195—1952, 522, club cpe... ..	....
207700—1951, 511, 2 dr. util... ..	....
207701—1951, 512, 2 dr. util... ..	....
213196—1952, 521, 2 dr. util... ..	....
213197—1952, 522, 2 dr. util... ..	....

### BODY SHELL, LESS DOORS AND DECK LID

207702—1951, 511, 4 dr. sed... ..	....
207703—1951, 512, 4 dr. sed... ..	....
213198—1952 to 53, 521, 4 dr. sed. ....	....
213199—1952 to 53, 522, 4 dr. sed. ....	....
207705—1951, 511, bus. cpe... ..	....
213201—1952, 521, bus. cpe... ..	....
213202—1952, 522, bus. cpe... ..	....
207706—1951, 511, 2 dr. sed... ..	....
207707—1951, 512, 2 dr. sed... ..	....
213203—1952 to 53, 521, 2 dr. sed. ....	....
213204—1952 to 53, 522, 2 dr. sed. ....	....
207708—1951, 511, 4 dr. util... ..	....
207709—1951, 512, 4 dr. util... ..	....
213205—1952, 521, 4 dr. util... ..	....
213206—1952 to 53, 522, 4 dr. util. ....	....
207710—1951, 512, club cpe... ..	....
213207—1952, 521, club cpe... ..	....
213208—1952, 522, club cpe... ..	....
207711—1951, 511, 2 dr. util... ..	....
207712—1951, 512, 2 dr. util... ..	....
213209—1952, 521, 2 dr. util... ..	....
213210—1952, 522, 2 dr. util... ..	....
214203—1953, 531 sdn. ....	665.00

### REAR STONE DEFLECTOR

213064—1951-52, exc. utility ..	5.58
213182—1952, exc. utility.....	4.50

213129—1951, utility .....	5.58
213183—1952, utility .....	4.92
213529—1953 exc. util. (right*) ..	22.50

### REAR STONE DEFLECTOR SEAL

207690—1951 .....	1.01
213184—1952 .....	1.00
213397—1952, extension seal..	.30
213610—1953, exc. util. ....	.65

### FUEL TANK

214364—1951 to 53 .....	20.35
-------------------------	-------

### 13 HOOD

208549—1951 .....	45.00
214303—1952 to 53 .....	45.00

### 14 AIR DUCT INLET FUNNEL

207526—1951 to 53 (right*) ..	5.58
-------------------------------	------

### AIR DUCT REAR OUTLET

207527—1951 .....	2.54
213045—1952 to 53 .....	2.51

### AIR DUCT VALVE AND COLLAR

207528—1951 to 53 (right*) ..	1.56
-------------------------------	------

### AIR DUCT COLLAR

208076—1951 to 53 (right*) ..	.35
-------------------------------	-----

### FRONT FENDER ACCESS COVER

208537—1951 to 53 (right*) ..	1.52
-------------------------------	------

### FRONT FENDER FRONT SHIELD

208534—1951 to 53 (right*) ..	3.85
-------------------------------	------

### FRONT FENDER UPPER REAR SHIELD

208541—1951 to 53 (right*) ..	3.85
-------------------------------	------

### FRONT FENDER LOWER REAR SHIELD

208544—1951 to 53 (right*) ..	4.55
-------------------------------	------

### 15 FRONT FENDER

208532—1951 (right*) .....	40.51
213234—1952 to 53 (right*) ..	40.51

### 16 STONE DEFLECTOR FRONT PANEL

207585—1951 .....	8.35
213721—1952-53 .....	11.55

### 17 RADIATOR UPPER CENTER GRILLE BAR

207545—1951 to 53 .....	10.91
-------------------------	-------

### RADIATOR UPPER GRILLE BAR

207547—1951 (right*) .....	2.37
----------------------------	------

### 18 RADIATOR LOWER GRILLE BAR

207583—1951 to 53 .....	10.91
-------------------------	-------

### 19 RADIATOR SHROUD

214415—1951 to 53 .....	3.77
-------------------------	------

### 20 RADIATOR

207531—1951 to 53 .....	58.86
-------------------------	-------

### 21 RADIATOR CRADLE

207533—1951 to 53 .....	12.50
-------------------------	-------

### 21 RADIATOR SPLASH PANEL

207538—1951 (left*) .....	2.43
213368—1952-53 (right*) .....	2.50

### 22 RADIATOR CRADLE TIE BRACE

207537—1951 to 53 .....	2.08
-------------------------	------

### RADIATOR CRADLE TO FENDER BRACKET

207535—1951 to 53 .....	1.67
-------------------------	------

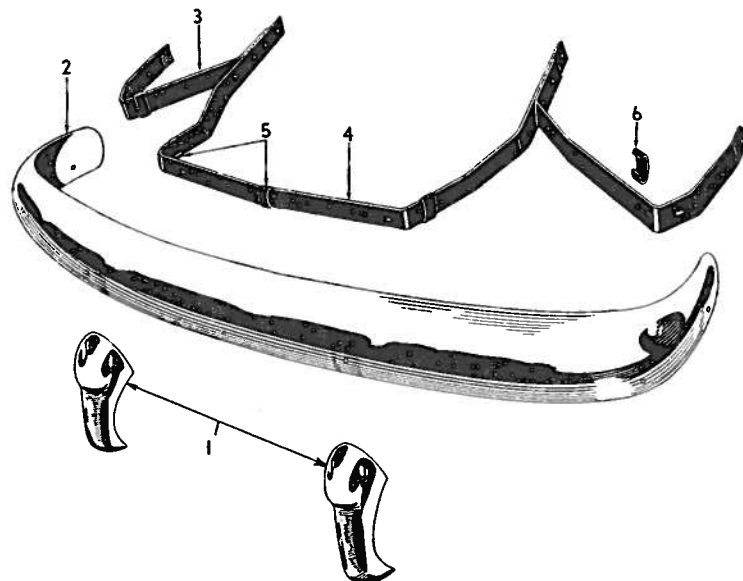

Fig. 2—Front Bumper and Attaching Parts

\* Opposite side one part number higher

# BODY PARTS 1951 thru 1953 KAISER

Models K511, K512, K521, K522, 530, 531 and 532. ALL BODY STYLES

## Front Bumper

See Fig. 2

<b>1 FRONT BUMPER GUARD</b>	
208512—1951, plain type (right*) .....	2.97
208517—1951, torpedo type (right*) .....	4.79
213641—1952-53, cap bridge (right) .....	5.85
<b>BUMPER WING</b>	
208514—1951, 512 (right*) ...	3.52
213644—1952-53, 522 (right*)	4.40
<b>2 BUMPER FACE BAR</b>	
208573—1951, not drilled for wings .....	24.11
208573—1951, drilled for wings	24.11
213628—1952-53 .....	24.11
<b>3 BUMPER OUTER SUPPORT</b>	
208502—1951 to 53 (right*) ..	2.97
<b>4 BUMPER INNER SUPPORT</b>	
208501—1951 .....	5.53
213631—1952 to 53 .....	6.95
<b>5 SUPPORT INNER INSULATOR</b>	
208504—1951 to 53 .....	.04
<b>6 SUPPORT OUTER INSULATOR</b>	
208505—1951 to 53 .....	.05
<b>BUMPER BAR BRACE</b>	
213632—1952 to 53 .....	.30

## Body Moldings, Wheels and Glass

2-Door Sedan 2-Door Utility and Coupes

See Fig. 3

<b>1 HOOD MEDALLION</b>	
208555—1951 .....	1.36
213247—1952-53 .....	1.25
<b>1 HOOD MEDALLION AND BASE</b>	
213246—1952-53 .....	4.00
<b>1 MEDALLION BASE</b>	
213248—1952-53 .....	3.15
<b>2 HOOD TOP ORNAMENT BODY</b>	
209582—1951 .....	2.52
213241—1952-53 .....	3.30
<b>2 HOOD TOP ORNAMENT BASE</b>	
209581—1951 .....	1.66
213242—1952-53 .....	1.98
<b>2 HOOD ORNAMENT RING</b>	
209583—1951, 511-12 .....	2.01
213515—1952-53, 521-22 .....	2.10
213244—1952-53, wing, 521-22.	2.79
213245—1952-53, fin, 521-22 ..	.35
<b>2 HOOD ORNAMENT NOSE</b>	
208554—1951 .....	.50
213516—1952-53 .....	.60
<b>3 HEADLIGHT SEALED BEAM UNIT</b>	
200810—1951-53 .....	1.41

<b>4 PARKING LIGHT</b>	
207367—1951 .....	4.75
213685—1952-53 .....	4.75
<b>4 PARKING LIGHT LENS</b>	
207369—1951 .....	.20
213687—1952-53 (right*) ....	1.80
<b>5 PARKING LIGHT DOOR BEZEL</b>	
207371—1951 to 53 .....	.96
<b>6 HEADLIGHT DOOR</b>	
200807—1951-52 .....	1.61
213915—1953, all (right*) ....	4.65
<b>7 WINDSHIELD DIVISION OUTER BAR</b>	
207651—1951 .....	.75
<b>8 WINDSHIELD LOWER MOLDING</b>	
207620—1951 to 53 .....	2.16
<b>9 WINDSHIELD GLASS</b>	
208353—1951 (right*) .....	27.70
213652—1952-53 .....	65.58
<b>10 WINDSHIELD MOLDING CORNER CLIP</b>	
207621—1951 to 53 .....	.20
<b>10 WINDSHIELD MOLDING CENTER CLIP</b>	
207649—1951 to 53 .....	.20
<b>11 WINDSHIELD UPPER MOLDING</b>	
207618—1951 to 53 (right*) ..	1.81

continued

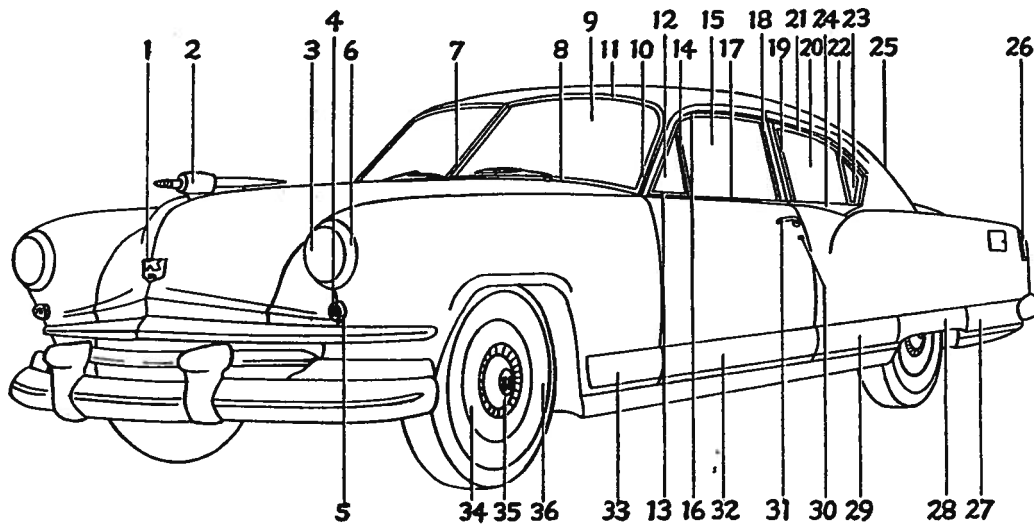

Fig. 3—Body Moldings, Wheels and Glass

\* Opposite side one part number higher

**KAISER 1951 thru 1953 BODY PARTS****Models K511, K512, K521, K522, 530, 531 and 532. ALL BODY STYLES****Body Moldings, Wheels and Glass—continued**

<b>11 WINDSHIELD WEATHERSTRIP</b>	213581—1952-53, bus. cpe., 2 dr. sed., club cpe., 2 dr. util. (right*) .....	<b>3.20</b>	212808—1952-53, 2 dr. sed. and 2 dr. util. (20.13 in. long)...	<b>.25</b>
208355—1951, 511, used without reveal molding .....			212809—1952-53, 2 dr. sed. and 2 dr. util. (24.30 in long) ...	<b>.30</b>
209629—1951, 511, used without reveal molding .....	<b>18 DOOR VERTICAL MOLDING</b>		<b>23 QUARTER PANEL GLASS RUN, FRONT CHANNEL</b>	
208356—1951, 512, used with reveal molding .....	207631—1951 to 53, 2 dr. sed., flat type (right*) .....	<b>2.03</b>	208177—1951 to 53, bus. cpe., 2 dr. sed., club cpe., 2 dr. util. (right*) .....	<b>.61</b>
212381—1951, 511-12, used with reveal molding .....	212416—1951 to 53, crown type (right*) .....	<b>2.33</b>	<b>23 QUARTER PANEL GLASS RUN, REAR CHANNEL</b>	
213653—1952-53 .....	<b>19 QUARTER PANEL WINDOW VERTICAL MOLDING</b>		208179—1951 to 53, bus. cpe. and club cpe. (right*) .....	<b>.85</b>
<b>12 DOOR VENTILATOR COMPLETE</b>	207631—1951 to 53, 2 dr. sed., flat type (right*) .....	<b>2.03</b>	<b>24 QUARTER PANEL WINDOW MOLDING</b>	
208119—1951-52 511-21, black (right*) .....	212416—1951 to 53, bus. cpe., 2 dr. sed., club cpe., 2 dr. util. crown type (right*) .....	<b>2.33</b>	212408—1951, 2 dr. sed. and 2 dr. util. (right*) .....	<b>3.85</b>
214022—1951-52, 511-12-22, chrome (right*) .....	212962—1951 to 53, bus. cpe. crown type, used with stationary window (right*) ...	<b>1.01</b>	212410—1951, club cpe. (right*) .....	<b>2.28</b>
214022—1953, 530, 1, 2 (right*)	<b>20 QUARTER PANEL WINDOW GLASS</b>		213591—1952, bus. cpe. (right*) .....	<b>2.70</b>
<b>12 VENTILATOR FRAME AND GLASS</b>	208105—1951-52, 2 dr. sed. and 2 dr. util. ....		213589—1952-53, 2 dr. sed. and 2 dr. util. (right*) .....	<b>4.25</b>
208123—1951-52, 511-21, black (right*) .....	212831—1951-52, bus. cpe., stationary .....		213591—1952-53, club cpe. (right*) .....	<b>2.70</b>
208125—1951-52, 511-12-22, chrome (right*) .....	208466—1951 to 53, 2 dr. sed. and 2 dr. util., rear glass .....		<b>25 REAR WINDOW UPPER REVEAL MOLDING</b>	
214028—1953, 530, 1, 2 (right*)	213885—1953, 2 dr. ....	<b>11.50</b>	207643—1951 to 53, bus. cpe., 2 dr. sed., club cpe. (right*) ..	<b>171</b>
<b>2 VENTILATOR FRAME WEATHERSTRIP</b>	<b>21 QUARTER PANEL WINDOW UPPER REVEAL MOLDING</b>		207645—1951 to 53, 2 dr. util. (right*) .....	<b>2.92</b>
208137—1951 to 53 (right*) ..	207639—1951 to 53, 2 dr. sed., flat type (right*) .....	<b>1.27</b>	<b>25 REAR WINDOW LOWER REVEAL MOLDING</b>	
<b>12 DOOR VENTILATOR GLASS</b>	212420—1951 to 53, 2 dr. sed. and 2 dr. util., crown type (right*) .....	<b>1.88</b>	207647—1951 to 53, bus. cpe., 2 dr. sed., club cpe. ....	<b>2.01</b>
208107—1951-52 .....	212422—1951 to 53, bus. cpe. and club cpe., crown type (right*) .....	<b>3.24</b>	207648—1951 to 53, 2 dr. util. .	<b>2.67</b>
213882—1953, all .....	212960—1951 to 53, bus. cpe. used with stationary window (right*) .....	<b>3.27</b>	<b>25 REAR WINDOW REVEAL MOLDING JOINT CLIP</b>	
<b>13 DOOR VENTILATOR MOLDING</b>	<b>22 QUARTER PANEL REAR GLASS DIVISION BAR</b>		207649—1951 to 53, center ....	<b>.20</b>
207628—1951 to 53 (right*) ..	208632—1951 to 53, 2 dr. sed. and 2 dr. util. (right*) .....	<b>2.87</b>	207650—1951 to 53, corner, bus. cpe., 2 dr. sed., club cpe. ...	<b>.20</b>
<b>14 VENTILATOR DIVISION BAR</b>	<b>23 QUARTER PANEL GLASS LOWER CHANNEL</b>		207621—1951 to 53, corner, 2 dr. util. ....	<b>.20</b>
208131—1951 to 53 (right*) ..	208173—1951 to 53, 2 dr. sed. and 2 dr. util. (right*) .....	<b>.75</b>	<b>25 REAR WINDOW GLASS</b>	
<b>15 DOOR GLASS</b>	<b>23 QUARTER WINDOW GLASS CHANNEL WEATHERSTRIP</b>		208399—1951-52, bus. cpe., 2 dr. sed., club cpe. ....	<b>32.70</b>
208103—1951 to 53, bus. cpe., 2 dr. sed., club cpe., 2 dr. util. ....	208175—1951, 2 dr. sed. and 2 dr. util. (20.13 in. long) ...	<b>.15</b>	207445—1951-52, 2 dr. util. ...	<b>27.65</b>
<b>16 DOOR UPPER REVEAL MOLDING</b>	208176—1951, 2 dr. sed. and 2 dr. util. (24.30 in. long) ....		213425—1953, all .....	<b>41.50</b>
207624—1951 to 53, 2 dr. sed., flat type (right*) .....			<b>25 REAR WINDOW GLASS WEATHERSTRIP</b>	
212414—1951 to 53, bus. cpe., 2 dr. sed., club cpe., 2 dr. util. crown type (right*) .....			208401—1951 to 53, all exc. 2 dr. util. used without reveal molding .....	<b>4.28</b>
<b>17 DOOR BELT MOLDING</b>				
212404—1951, bus. cpe., 2 dr. sed., club cpe., 2 dr. util. (right*) .....				

\* Opposite side one part number higher

**BODY PARTS 1951 thru 1953 KAISER****Models K511, K512, K521, K522, 530, 531 and 532. ALL BODY STYLES**

208401—1951 to 53, all exc. 2 dr. util. used with reveal molding ..... 4.28	207521—1951 to 53, 2 dr. util. used with reveal molding ... 4.32	<b>33 FRONT FENDER RUB RAIL MOLDING</b> 212782—1951 to 53, 511-21, 531 ..... 75 207596—1951 to 53, 512-22, 530, 2 (right*) ..... 2.67	<b>2 HOOD ORNAMENT RING</b> 209583—1951, 511-12 ..... 2.01 213515—1952, 521-22 ..... 2.10 213244—1952, wing, 521-22 ... 2.79 213245—1952, fin, 521-22 ..... .35
<b>26 TAIL LIGHT ASSY.</b> 207375—1951 (right*) ..... 7.75 213692—1952-53 (right*) ..... 12.00	<b>26 TAIL LIGHT BODY</b> 207378—1951 (right*) ..... 3.93 213813—1952-53 (right*) ..... 7.45	<b>33 RUB RAIL MOLDING CLIPS</b> 212783—1951 to 53, 511-21, 531 ..... .05 207598—1951 to 53, 512-22, 530, 2 ..... .05	<b>2 HOOD ORNAMENT NOSE</b> 208554—1951 ..... .50 213516—1952 ..... .60
<b>26 TAIL LIGHT MOUNTING PAD</b> 207377—1951 ..... .35 213694—1952-53 (right*) ..... .95	<b>26 TAIL LIGHT LENS</b> 207381—1951, incl. reflex lens (right*) ..... 1.71 204520—1951, lens, reflex red plastic ..... .20 213696—1952-53, inner, incl. reflex button (right*) ..... 2.10 213698—1952-53, outer, red plastic (right*) ..... 3.75	<b>34 WHEEL TRIM RING</b> 205728—1951 ..... 3.78	<b>3 HEADLIGHT SEALED BEAM UNIT</b> 200810—1951 to 53 ..... 1.41
<b>26 TAIL LIGHT LENS GASKET</b> 207383—1951 ..... .15 213700—1952-53 ..... .10	<b>27 QUARTER PANEL RUB RAIL EXTENSION MOLDING</b> 207616—1951, 512 (right*) ... 2.77 213596—1952-53, 522 (right*) . 4.80	<b>34 WHEEL COVER AND DISC</b> 208601—1951 ..... 5.94 214410—1952-53 ..... 6.75	<b>4 PARKING LIGHT</b> 207367—1951 ..... 4.75 213685—1952-53 ..... 4.75
<b>28 REAR WHEEL OPENING COVER</b> 207609—1951 to 53 (right*) .. 6.59	<b>29 QUARTER PANEL RUB RAIL MOLDING</b> 212791—1951, 511 ..... 2.97 207605—1951, 512 (right*) ... 4.38 213595—1952-53, 521, 531 ..... 3.20	<b>35 WHEEL HUB CAP</b> 204658—1951, 511, early ..... 3.50 208525—1951, 511-12, late.... 3.95 213755—1952-53, 521-22, 530, 1, 2 ..... 3.95	<b>4 PARKING LIGHT LENS</b> 207369—1951 ..... .20 213687—1952-53 (right*) ..... 1.80
<b>30 LOCK CYLINDER AND KEY KIT</b> 207344—1951, 511-12 ..... 1.45 213388—1952-53, 521-22, 530, 1, 2 ..... 3.50	<b>31 DOOR HANDLE</b> 207844—1951 to 53 ..... 2.27	<b>36 WHEEL</b> 203258—1951 to 53 (15 in.) ... 9.55	<b>5 PARKING LIGHT DOOR BEZEL</b> 207371—1951-52 ..... .96
<b>32 DOOR RUB RAIL MOLDING</b> 212785—1951 to 53, 511-21, 531 ..... 1.76 207601—1951 to 53, 512-22, 530, 2 (right*) ..... 6.04		<b>FRONT FENDER NAME PLATE</b> 213598—1952-53, 521-22, 530 "Kaiser" ..... 1.00 213600—1952-53, 521, 531 "Deluxe" ..... 1.00 213599—1952-53, 522, 532 "Manhattan" ..... 1.00 205634—1952, 521-22 "Virginian" ..... 1.00	<b>6 HEADLIGHT DOOR</b> 200807—1951-52 ..... 1.61 213915—1953, all (right*) .... 4.65
		<b>Body Moldings, Wheels and Glass</b> <i>4-Door Sedan and 4-Door Utility</i> <i>See Fig. 4, Page 558</i>	<b>7 WINDSHIELD DIVISION, OUTER BAR</b> 207651—1951-52 ..... .75
		<b>1 HOOD MEDALLION</b> 208555—1951 ..... 1.36 213247—1952-53 ..... 1.25	<b>8 WINDSHIELD LOWER MOLDING</b> 207620—1951 to 53 ..... 2.16
		<b>1 HOOD MEDALLION AND BASE</b> 213246—1952-53 ..... 4.00	<b>9 WINDSHIELD GLASS</b> 208353—1951 (right*) ..... 27.70 213652—1952-53 ..... 65.58
		<b>1 MEDALLION BASE</b> 213248—1952-53 ..... 3.15	<b>10 WINDSHIELD MOLDING CORNER CLIP</b> 207621—1951 to 53 ..... .20
		<b>2 HOOD TOP ORNAMENT BODY</b> 209582—1951 ..... 2.52 213241—1952-53 ..... 3.30	<b>10 WINDSHIELD MOLDING CENTER CLIP</b> 207649—1951 to 53 ..... .20
		<b>2 HOOD TOP ORNAMENT BASE</b> 209581—1951 ..... 1.66 213242—1952-53 ..... 1.98	<b>11 WINDSHIELD UPPER MOLDING</b> 207618—1951 to 53 (right*) .. 1.81
			<b>11 WINDSHIELD WEATHERSTRIP</b> 208355—1951, 511, used without reveal molding ..... 6.30 209629—1951, 511, used without reveal molding ..... 6.04 208356—1951, 512, used with reveal molding ..... 8.01 212381—1951, 511-512, used with reveal molding ..... 6.04 213653—1952-53 ..... 5.70

*continued*

\* Opposite side one part number higher







**KAISER 1951 thru 1953 BODY PARTS**

*Models K511, K512, K521, K522, 530, 531 and 532. ALL BODY STYLES*

**Front Door—continued**

<b>9 VENTILATOR LOCK HANDLE</b> 208160—1951 to 53 (right*) ..	.55
<b>10 DOOR UPPER HINGE</b> 207834—1951 to 53 (right*) ..	.96
<b>10 DOOR LOWER HINGE</b> 207836—1951 to 53 (right*) ..	.86
<b>11 DOOR CHECK ARM</b> 207843—1951 to 53 .....	.40
<b>12 DOOR HINGE PILLAR WEATHERSTRIP</b> 213454—1951 to 53 (48 in. long)	2.20
<b>12 FRONT DOOR OPENING WEATHER SEAL</b> 213454—1951, 4 dr. sed. and 4 dr. util. (100.50 in. long) ...	2.20
213456—1951, bus cpe., 2 dr. sed., club cpe., 2 dr. util. (132 in. long) .....	2.10
213454—1952-53, 4 dr. sed. and 4 dr. util. (160 in. long) ....	2.20
213456—1952-53, bus. cpe., 2 dr. sed., club cpe., 2 dr. util. (169 in. long) .....	2.10
<b>13 FRONT DOOR</b> 207811—1951 to 53, 4 dr. sed. and 4 dr util. (right*) .....	50.20
207813—1951 to 53, bus. cpe., 2 dr. sed., club cpe., 2 dr. util. (right*) .....	55.27

<b>14 DOOR WINDOW REGULATOR</b> 208163—1951 to 53, 4 dr. sed. and 4 dr. util. (right*) .....	3.27
208165—1951 to 53, bus. cpe., 2 dr. sed., club cpe., 2 dr. util. (right*) .....	3.98
<b>14 REGULATOR HANDLE</b> 208167—1951-52 .....	1.11
214299—1953, exc. club cpe. ...	.95
<b>14 REGULATOR HANDLE ESCUTCHEON</b> 207833—1951-52 .....	.50
213489—1953, exc. club cpe. (17/32 in.) .....	.15
214300—1953, exc. club cpe. (13/16 in.) .....	.25
<b>14 ESCUTCHEON SPRING</b> 209515—1951 to 53 .....	.05
<b>14 REGULATOR HANDLE PIN</b> 202313—1951 to 53 .....	.05
<b>15 DOOR LOCK REMOTE CONTROL AND LINK</b> 207827—1951 to 53, 4 dr. sed. and 4 dr. util. (right*) .....	.90
207829—1951 to 53, bus. cpe., 2 dr. sed., club cpe., 2 dr. util. (right*) .....	.76
<b>15 REMOTE CONTROL HANDLE</b> 207832—1951-52 .....	.91
212256—1953, all .....	.65

<b>15 REMOTE CONTROL HANDLE ESCUTCHEON</b> 207833—1951-52 .....	.50
214300—1953, all .....	.25
<b>15 HANDLE ESCUTCHEON SPRING</b> 209515—1951 to 53 .....	.05
<b>15 REMOTE CONTROL HANDLE PIN</b> 202313—1951 to 53 .....	.05
<b>DOOR HANDLE</b> 207844—1951 to 53 .....	2.27
<b>DOOR HANDLE ESCUTCHEON</b> 207846—1951 to 53 .....	1.01
<b>DOOR LOCK</b> 207822—1951 to 53 (right*) ..	2.42

**Rear Door**

*4-Door Sedan and Utility  
See Fig. 6*

<b>1 REAR DOOR GLASS</b> 208104—1951-52 .....	.....
213883—1953, all .....	13.00
<b>2 DOOR GARNISH MOLDING</b> 207853—1951 to 53 (right*) ..	7.35
<b>3 DOOR GLASS RUN, FRONT CHANNEL</b> 208168—1951 to 53 (right*) ..	.60
<b>3 DOOR GLASS LIFTER, LOWER CHANNEL</b> 208170—1951 to 53 (right*) ..	.75
<b>4 CHANNEL WEATHERSTRIP</b> 208172—1951 (25 in. long) ...	.20
212807—1952-53 (25 in. long) .	.30
<b>5 VENTILATOR FRAME WEATHERSTRIP</b> 208194—1951 to 53 (right*) ..	.91
<b>6 VENTILATOR DIVISION BAR</b> 208198—1951 to 53 (right*) ..	2.52
<b>7 VENTILATOR FRAME AND GLASS</b> 208190—1951-52, black (right*)	6.54
208192—1951-52, chrome (right*) .....	7.55
214045—1953, all (right*) ....	7.55
<b>8 VENTILATOR COMPLETE</b> 208186—1951-52, 511-21, black (right*) .....	14.45
214039—1951-52, chrome (right*) .....	15.85
214039—1953, all (right*) ....	15.85

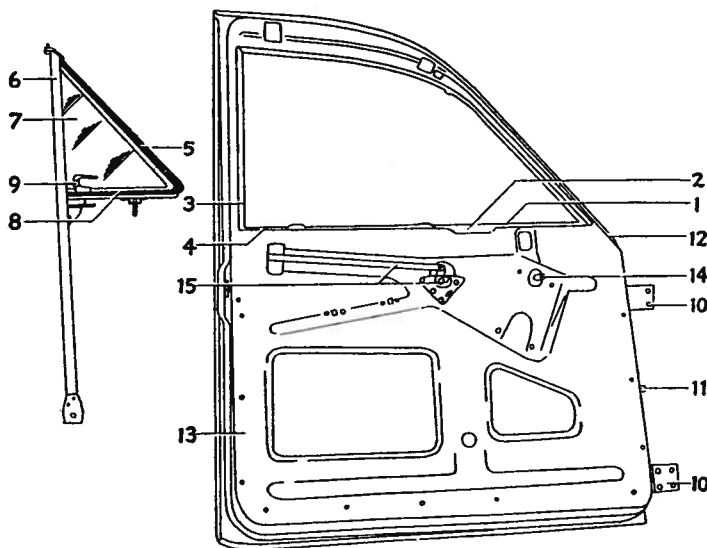

**Fig. 5—Front Door Assembly**

*\* Opposite side one part number higher*

**BODY PARTS 1951 thru 1953 KAISER**

**Models K511, K512, K521, K522, 530, 531 and 532. ALL BODY STYLES**

<b>9 HANDLE COMPLETE</b>	
208460—1951-52 (right*) .....	1.11
214049—1953, all (right*) ....	1.15
<b>9 HANDLE</b>	
204719—1951-52 (right*) ....	.55
214051—1953, all (right*) ....	.50
<b>9 VENTILATOR LOCK HANDLE STRIKER</b>	
208212—1951 to 53 .....	.10
<b>10 DOOR HINGE</b>	
207884—1951 to 53 (right*) ..	1.20
<b>11 DOOR CHECK ARM</b>	
207888—1951 to 53 .....	.40
<b>11 DOOR CHECK ARM GUIDE</b>	
206021—1951 to 53 .....	.05
<b>12 HINGE PILLAR WEATHER-STRIP</b>	
213455—1951 to 53 .....	2.20
<b>12 DOOR OPENING WEATHER-SEAL</b>	
213455—1951 (116 in. long) ..	2.20
213455—1952-53 (155 in. long)	2.20
<b>13 REAR DOOR</b>	
207870—1951 to 53 (right*) ..	50.20
<b>14 DOOR WINDOW REGULATOR</b>	
208214—1951 to 53 (right*) ..	3.78
<b>14 REGULATOR HANDLE</b>	
208167—1951-52 .....	1.11
214299—1953, 531 .....	.95
<b>14 REGULATOR HANDLE ESCUTCHEON</b>	
207833—1951-52 .....	.50
213489—1953, 531 (17/32 in.) .	.15
214300—1953, 531 (13/16 in.) .	.25
<b>14 ESCUTCHEON SPRING</b>	
209515—1951 to 53 .....	.05
<b>14 HANDLE PIN</b>	
202313—1951 to 53 .....	.05
<b>15 DOOR LOCK REMOTE CONTROL AND LINK</b>	
207882—1951 to 53 (right*)...	.76
<b>15 REMOTE CONTROL HANDLE</b>	
207832—1951 to 53, exc. 531...	.91
212256—1953, 531 .....	.65
<b>15 HANDLE ESCUTCHEON</b>	
207833—1951 to 53, exc. 531 ..	.50
214300—1953, 531 .....	.25

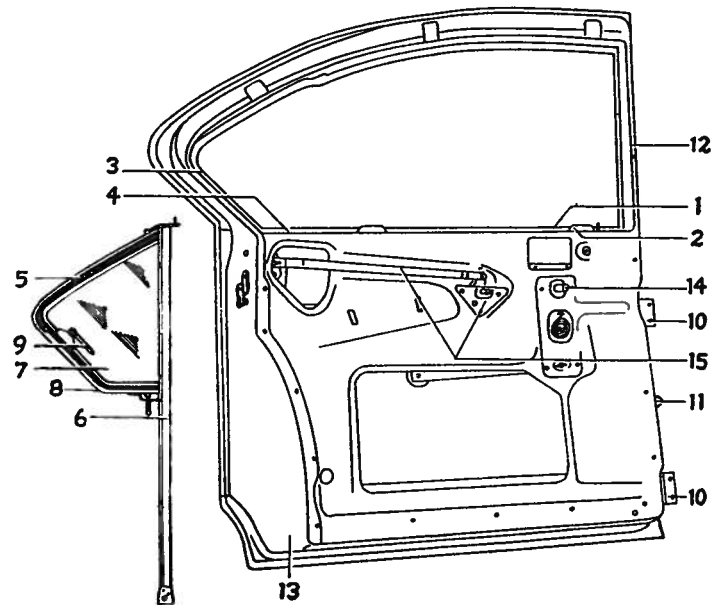

Fig. 6—Rear Door Assembly

<b>15 HANDLE ESCUTCHEON SPRING</b>	
209515—1951 to 53 .....	.05
<b>DOOR LOCK</b>	
207877—1951 to 53 .....	2.40
<b>DOOR HANDLE</b>	
207844—1951 to 53 .....	2.27
<b>DOOR HANDLE ESCUTCHEON</b>	
207846—1951 to 53 .....	1.01
<b>DOOR HANDLE SPRING</b>	
207849—1951 to 53 .....	.03
<b>DOOR HANDLE BEARING</b>	
207850—1951 to 53 .....	.03

<b>1 LICENSE LIGHT LENS</b>	
207391—1951, exc. utility ....	.30
206233—1951, utility .....	.40
213225—1952-53, exc. utility ..	.25
<b>1 LICENSE LIGHT LENS RETAINER</b>	
207393—1951 to 53, exc. utility	.15
<b>1 LICENSE LIGHT LENS GASKET</b>	
207392—1951, exc. utility ....	.10
206234—1951, utility .....	.15
213226—1952-53, exc. utility...	.10
<b>1 LICENSE LIGHT DOOR</b>	
207389—1951, exc. utility .....	2.01
206530—1951, utility .....	1.41
213227—1952-53, exc. utility...	.30

<b>2 DECK LID BOTTOM WEATHER-STRIP</b>	
207896—1951 to 53, exc. utility	.45
207896—1951-52, lower lid bottom, utility .....	.45
207895—1951-52, upper lid lower, utility .....	1.51
214377—1953, 531, bottom low. lid .....	.65
<b>3 REAR DECK LID</b>	
207889—1951, exc. utility ....	37.01
207890—1951-52, upper, utility	40.26
207891—1951-52, lower, utility	38.03
213215—1952-53, exc. utility ..	37.00
213930—1953, 530, 1, 2 .....	36.50

**Rear of Car**  
*Typical of All Body Styles*  
 See Fig. 7, Page 562

<b>1 LICENSE LIGHT</b>	
207385—1951, exc. utility ....	11.84
213224—1952-53, exc. utility ..	2.10
212816—1951, utility .....	11.02
213550—1952, 521, 2 .....	2.95
<b>1 LICENSE LIGHT MOUNTING PAD</b>	
208032—1951 to 53, exc. utility	.40
212565—1951 to 53, utility ....	.08

continued

\* Opposite side one part number higher

# KAISER 1951 thru 1953 BODY PARTS

Models K511, K512, K521, K522, 530, 531 and 532. ALL BODY STYLES

## Rear of Car—continued

<b>4 DECK LID LOCK LATCH AND LINK</b>	
209651—1951, exc. utility . . . .	1.26
213033—1952-53, exc. utility ..	1.46
<b>5 DECK LID PROP</b>	
207905—1951, exc. utility . . . .	1.01
<b>5 DECK LID UPPER SUPPORT</b>	
207908—1951, utility (right*) .	2.02
213444—1952-53, utility (right*) .....	3.25
<b>5 UPPER LID SUPPORT SPRING</b>	
206522—1951, utility .....	.75
213442—1952-53, utility .....	.75
<b>5 UPPER LID SUPPORT LOCKING BRACKET</b>	
207388—1951-52, utility .....	.35
<b>DECK LID HANDLE</b>	
207395—1951, exc. utility . . . .	3.47
207845—1951 to 53, lower lid, utility .....	5.07
213218—1952-53, exc. utility ..	4.85
<b>6 DECK LID HINGE</b>	
207898—1951-52, exc. utility (right*) .....	1.76
207900—1951-52, upper lid, utility .....	1.61

207901—1951-52, lower lid (on lid) utility .....	7.80
207902—1951-52, lower lid (on body) utility (right*) .....	1.96
213931—1953, 530, 1, 2 (right*)	4.00

<b>7 DECK LID, UPPER AND SIDES WEATHERSTRIP</b>	
207892—1951 to 53, exc. utility	1.11
207894—1951-52, upper lid, top, utility .....	.50
208660—1951, sides, utility . . .	1.81
213522—1952-53, upper corners, exc. utility .....	.03

<b>8 TAIL LIGHT ASSY.</b>	
207375—1951 (right*) .....	7.75
213692—1952-53 (right*) .....	12.00

<b>8 TAIL LIGHT BODY</b>	
207378—1951 (right*) .....	3.93
213813—1952-53 (right*) .....	7.45

<b>8 TAIL LIGHT MOUNTING PAD</b>	
207377—1951 .....	.35
213694—1952-53 (right*) .....	.95

<b>9 TAIL LIGHT LENS</b>	
207381—1951, incl. reflex lens (right*) .....	1.71
204520—1951, lens, reflex red plastic .....	.20
213696—1952-53, inner, incl. reflex button (right*) .....	2.10
213698—1952-53, outer, red plastic (right*) .....	3.75

<b>9 TAIL LIGHT LENS GASKET</b>	
207383—1951 .....	.15
213700—1952-53 .....	.10

<b>10 REAR BUMPER FACE BAR</b>	
208506—1951, exc. utility . . . .	22.80
208507—1951, utility .....	22.80
213634—1952-53, exc. utility ..	16.25
213635—1952-53, utility .....	16.25

<b>11 REAR BUMPER GUARD</b>	
208513—1951, plain type (right*) .....	2.97
208518—1951, torpedo type (right*) .....	4.79
213646—1952-53, cap bridge (right) .....	6.55

<b>REAR BUMPER SUPPORT</b>	
208508—1951, inner (right*)..	1.96
213638—1952, inner .....	5.60
208510—1951, outer (right*)..	1.96
213639—1952-53, outer (right*)	2.60

<b>12 REAR STONE DEFLECTOR</b>	
213064—1951, exc. utility . . . .	5.58
213129—1951 .....	5.58
213182—1952-53, exc. utility ..	4.50

## Spare Wheel Carrier

Models 521-522

See Fig. 8

<b>1 REAR BUMPER GUARD</b>	
208518—1952, torpedo type... ..	4.79
213641—1953 (right*) .....	5.85

<b>2 REAR BUMPER FACE BAR</b>	
208506—1952 .....	22.80
213634—1953, exc. util. ....	16.25

<b>3 SUPPORT HINGE</b>	
213539—1952-53 .....	11.00

<b>4 HINGE PIN</b>	
213541—1952-53 .....	.95

<b>5 SUPPORT BAR</b>	
213538—1952-53 .....	8.85

<b>6 REAR BUMPER INNER SUPPORT</b>	
213638—1952-53 .....	5.60

<b>7 REAR BUMPER OUTER SUPPORT</b>	
213639—1952-53 (right*) .....	2.60

<b>8 REAR BUMPER SUPPORT EXTENSION</b>	
213533—1952-53 .....	4.50

<b>9 LICENSE LIGHT CABLE CLIP</b>	
205693—1952-53 .....	.02

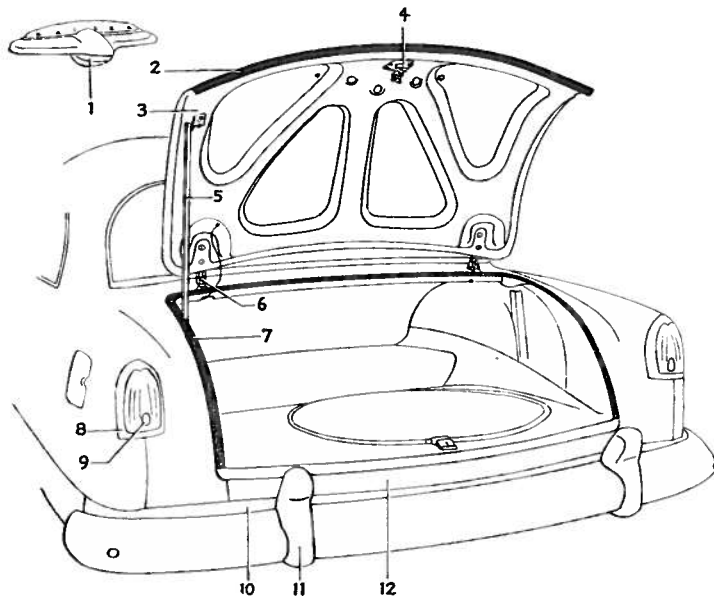

Fig. 7—Rear of Car

\* Opposite side one part number higher

**BODY PARTS 1951 thru 1953 KAISER**

**Models K511, K512, K521, K522, 530, 531 and 532. ALL BODY STYLES**

<b>10 SUPPORT</b>		
213537—1952-53 .....	17.00	
<b>11 WHEEL CARRIER</b>		
213540—1952-53 .....	31.00	
<b>12 TIRE SIDE COVER, INCL. BRACKET</b>		
213526—1952-53 .....	17.95	
<b>13 LOCK AND KEYS</b>		
213551—1952-53 .....	3.25	
<b>14 WHEEL HUB CAP</b>		
213527—1952-53 .....	3.50	
<b>15 LICENSE PLATE HUB CAP BRACKET</b>		
213549—1952-53 .....	.45	
<b>16 LICENSE PLATE BRACKET</b>		
213548—1952-53 .....	.65	
<b>17 LICENSE LIGHT COMPLETE</b>		
213550—1952-53 .....	2.95	
213224—1953, all .....	2.10	
<b>18 TIRE TOP COVER</b>		
213710—1952-53 .....	25.00	
<b>19 TIRE COVER SPACER</b>		
213528—1952-53 .....	.15	
<b>20 TIRE COVER SPACER NUT</b>		
202—1952-53 .....	.02	
<b>21 SUPPORT BRACKET, INCL. LATCH AND BUMPERS (ON DECK LID)</b>		
213543—1952-53 .....	3.50	
<b>22 SUPPORT BRACKET GASKET SCREW</b>		
936—1952-53 .....	.02	

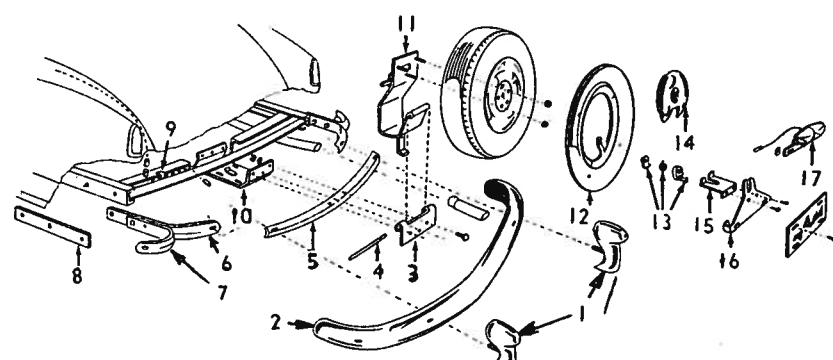
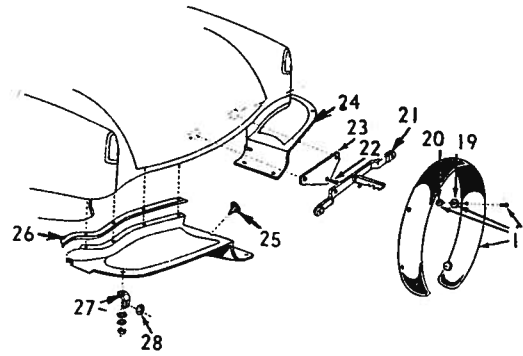

Fig. 8—Spare Wheel Carrier

<b>23 SUPPORT BRACKET GASKET</b>			<b>26 REAR STONE DEFLECTOR TO BODY WELT</b>	
213544—1952-53 .....	.15		213531—1952 .....	4.50
<b>24 REAR STONE DEFLECTOR</b>			213182—1953, all .....	....
213529—1952-53 (right*) .....	22.50		<b>27 REAR STONE DEFLECTOR BRACKET</b>	
<b>25 REAR STONE DEFLECTOR BUMPER</b>			213532—1952-53 .....	1.10
200627—1952-53 .....	.04			<i>continued</i>

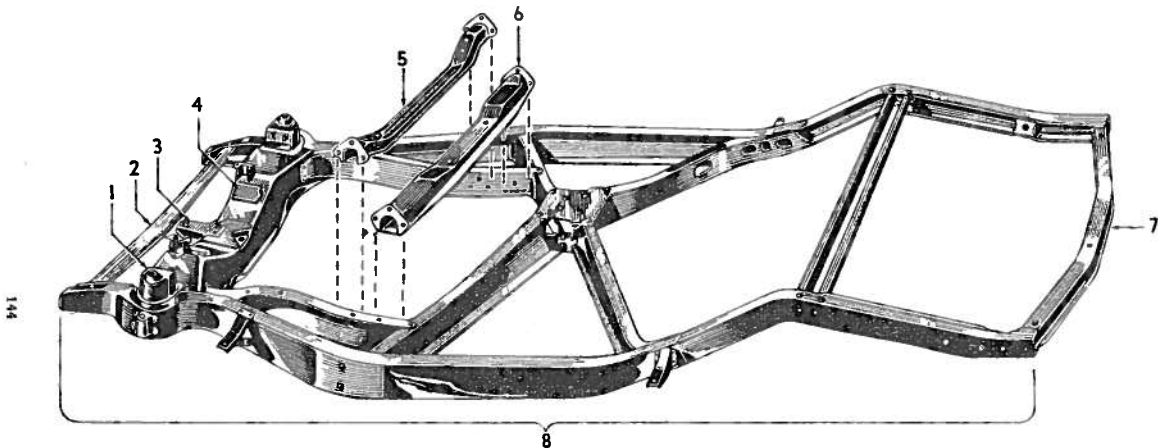

Fig. 9—Frame Assembly

\* Opposite side one part number higher

# KAISER 1951 thru 1953 BODY PARTS

Models K511, K512, K521, K522, 530, 531 and 532. ALL BODY STYLES

## Spare Wheel Carrier— continued

28 REAR STONE DEFLECTOR SPACER TO BUMPER BAR 247—1952-53 .....	.01
---	-----

## Frame Assembly

See Fig. 9 Page 563

<b>1 FRONT SHOCK ABSORBER SUPPORT</b> 208638—1951-52 .....	2.52
212451—1953, all .....	2.47
<b>2 AIR SCOOP SUPPORT</b> 208653—1951 to 53 .....	1.01
<b>3 RADIATOR MOUNTING BRACKET</b> 208658—1951 to 53 .....	.86
<b>4 CROSS MEMBER NO. 1</b> 208654—1951-52 .....	22.75
214340—1953, all .....	22.75
<b>5 CROSS MEMBER NO. 2, WITH HYDRA-MATIC</b> 208656—1951 to 53 .....	3.27
<b>6 CROSS MEMBER NO. 2, LESS HYDRA-MATIC</b> 208655—1951 to 53 .....	2.37

<b>7 CROSS MEMBER NO. 4, REAR</b> 208657—1951 to 53 .....	1.01
<b>8 FRAME LESS NO. 2 CROSS MEMBER</b> 214339—1951 .....	107.85
214339—1952 to 53 .....	107.85

## Front Suspension

See Fig. 10

<b>1 SHOCK ABSORBER</b> 214294—1951 .....	5.93
214294—1952-53, stamped 735173 .....	5.93
<b>2 UPPER SPRING SEAT</b> 204357—1951 to 53 .....	.40
<b>3 SPRING UPPER INSULATOR</b> 201112—1951 to 53 .....	.15
<b>4 SHOCK ABSORBER CUSHION RETAINER</b> 201015—1951-52, 13/32 in. I.D. ....	.10
202867—1951-52, 1/2 in. I.D. ....	.05
201118—1951 to 53, pilot, 9/16 in. I.D. ....	.02

<b>5 SHOCK ABSORBER CUSHION</b> 206651—1951 to 53 .....	.05
<b>6 SHOCK ABSORBER CUSHION LOWER SUPPORT</b> 204854—1951 to 53 .....	.25
<b>7 LOWER SPRING INSULATOR</b> 204355—1951 to 53 .....	.25
<b>8 SHOCK ABSORBER CUSHION LOWER SEAT</b> 201491—1951 to 53 .....	.15
<b>9 SHOCK ABSORBER LOCK NUT</b> 202257—1951 to 53 .....	.05
<b>10 FRONT SUSPENSION UPPER ARM</b> 201096—1951-52 .....	3.42
214297—1953, all .....	3.65
<b>11 UPPER ARM INNER PIVOT SHIM</b> 208346—1951 to 53, 1/16 in. ....	.05
208347—1951 to 53, 1/8 in. ....	.08
<b>12 UPPER ARM INNER PIVOT</b> 208345—1951-52 .....	1.91
214112—1953, all .....	1.46

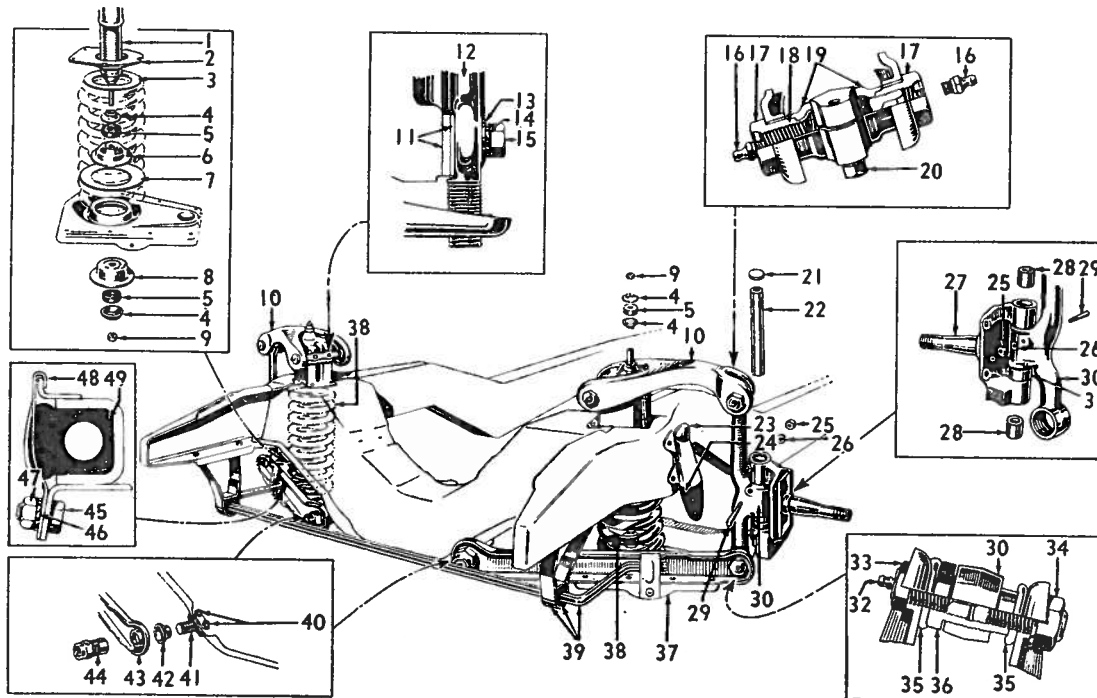

Fig. 10—Front Suspension

\* Opposite side one part number higher

**BODY PARTS 1951 thru 1953 KAISER****Models K511, K512, K521, K522, 530, 531 and 532. ALL BODY STYLES**

<b>2 UPPER ARM INNER PIVOT REPAIR KIT</b>		<b>28 KING PIN BUSHING (Free floating)</b>		<b>43 LOWER ARM</b>	
208591—1951-52 .....	3.32	203515—1951 to 53 .....	.40	214285—1951 (right*) .....	5.25
214311—1953, all .....	2.60			214285—1952-53 .....	5.25
<b>3 UPPER ARM PIVOT INNER FLAT WASHER</b>		<b>29 KING PIN LOCK PIN</b>		<b>44 LOWER ARM BUSHING</b>	
222—1951 to 53 .....	.02	203003—1951 to 53, threaded, small .....	.25	212699—1951 to 53 .....	.55
		206194—1951 to 53, threaded, large .....	.25	<b>45 SWAY ELIMINATOR RETAINER BOLT</b>	
<b>4 UPPER ARM PIVOT LOCK WASHER</b>				274—1951 to 53 .....	.04
342—1951 to 53, 9/16 in. med. ....	.02	<b>30 STEERING KNUCKLE SUPPORT</b>		<b>46 RETAINER LOCK WASHER</b>	
		201119—1951 to 53 (right*) ..	6.54	240—1951 to 53 .....	.01
<b>5 UPPER ARM PIVOT INNER BOLT</b>		<b>31 KING PIN THRUST BEARING</b>		<b>47 RETAINER BOLT NUT</b>	
869—1951 to 53 .....	.15	201133—1951 to 53 .....	.70	189—1951 to 53 .....	.02
<b>6 UPPER ARM OUTER PIVOT OILER</b>		<b>32 LOWER ARM OUTER PIVOT OILER</b>		<b>48 SWAY ELIMINATOR RETAINER</b>	
202120—1951 to 53 .....	.10	202121—1951 to 53 .....	.10	204359—1951 .....	.10
				213132—1952-53 .....	.40
<b>7 UPPER ARM OUTER PIVOT BUSHING</b>		<b>33 LOWER ARM OUTER PIVOT REPAIR KIT</b>		<b>49 SWAY ELIMINATOR CUSHION (Bar ends)</b>	
201122—1951 to 53 .....	.45	205781—1951 to 53 .....	1.41	204358—1951 to 53 .....	.55
<b>8 UPPER ARM OUTER PIVOT REPAIR KIT</b>		<b>34 LOWER ARM OUTER PIVOT NUT</b>			
205779—1951 to 53 .....	1.76	203876—1951 to 53 .....	.30		
<b>9 UPPER ARM OUTER PIVOT SEAL</b>		<b>35 LOWER ARM OUTER PIVOT SEAL</b>			
201123—1951 to 53 .....	.10	201127—1951 to 53 .....	.10		
<b>10 KNUCKLE SUPPORT BOLT</b>		<b>36 LOWER ARM OUTER PIVOT BUSHING</b>			
484—1951 to 53 .....	.05	201126—1951 to 53 .....	.50		
<b>11 KNUCKLE EXPANSION PLUG</b>		<b>37 LOWER ARM</b>			
476—1951 to 53 .....	.02	214285—1951 (right*) .....	5.25		
<b>22 STEERING KNUCKLE KING PIN</b>		214285—1952 .....	5.25		
201130—1951 to 53 .....	.85	214285—1953, all .....	5.25		
<b>22 STEERING KNUCKLE REPAIR KIT</b>		<b>38 FRONT COIL SPRING</b>			
205777—1951 to 53 .....	2.81	208368—1951 to 53 (brown) early cars .....	6.85		
<b>23 UPPER ARM BUMPER</b>		208368—1951 to 53 (white) late cars .....	6.85		
207143—1951 to 53 .....	.15	<b>39 FRONT SWAY ELIMINATOR BAR</b>			
<b>24 LOWER ARM BUMPER</b>		205305—1951 to 53 .....	5.54		
202948—1951 to 53 .....	.60	<b>40 LOWER ARM INNER PIVOT LOCKNUT</b>			
<b>25 KING PIN LOCK PIN NUT</b>		202296—1951 to 53 .....	.05		
188—1951 to 53 .....	.02	<b>41 LOWER ARM INNER PIVOT REPAIR KIT</b>			
<b>26 LOCK PIN LOCK WASHER</b>		205782—1951 to 53 .....	3.68		
192—1951 to 53 .....	.02	<b>42 LOWER ARM BUSHING SEAL</b>			
<b>27 STEERING KNUCKLE</b>		201109—1951 to 53 .....	.15		
205151—1951 to 53 (right*) ..	10.65				

**STEERING GEOMETRY**

1951-53

**CASTER:** 1 degree negative to 1 degree positive.

**CAMBER:** 0 to  $\frac{3}{4}$  degree positive.

**TOE-IN:** 0 to 1/16 inch.

**TOE-OUT TURNS (TURNING RADIUS):**  
Outer Wheel 20 degrees. Inner Wheel 22 degrees.

**KING PIN INCLINATION:** 5 $\frac{1}{2}$  degrees.

**ADJUSTMENTS**

**CASTER and CAMBER** adjusted at the upper eccentric pin.

\* Opposite side one part number higher